



CARIBBEAN EXAMINATIONS COUNCIL

CAPE[®] Physics

**SYLLABUS
SPECIMEN PAPER
MARK SCHEME
SUBJECT REPORTS**

Macmillan Education
4 Crinan Street, London, N1 9XW
A division of Springer Nature Limited
Companies and representatives throughout the world

www.macmillan-caribbean.com

ISBN 978-0-230-48256-2

© Caribbean Examinations Council (CXC®) 2019
www.cxc.org
www.cxc-store.com

The author has asserted their right to be identified as the author of this work in accordance with the Copyright, Design and Patents Act 1988.

First published 2014

This revised edition published 2019

Permission to copy

The material in this book is copyright. However, the publisher grants permission for copies to be made without fee. Individuals may make copies for their own use or for use by classes of which they are in charge; institutions may make copies for use within and by the staff and students of that institution. For copying in any other circumstances, prior permission in writing must be obtained from Macmillan Education Limited. Under no circumstances may the material in this book be used, in part or in its entirety, for commercial gain. It must not be sold in any format.

Designed by Macmillan Education Limited
Cover design by Macmillan Education Limited and Red Giraffe

CAPE® Physics Free Resources

LIST OF CONTENTS

CAPE® Physics Syllabus Extract	3
CAPE® Physics Syllabus	4
CAPE® Physics Specimen Papers and Mark Schemes:	119
Unit 1 Paper 01	122
Mark Scheme	137
Unit 1 Paper 02	138
Mark Scheme	158
Unit 1 Paper 032	167
Mark Scheme	179
Unit 2 Paper 01	183
Mark Scheme	197
Unit 2 Paper 02	198
Mark Scheme	219
Unit 2 Paper 032	230
Mark Scheme	242
CAPE® Physics Subject Reports:	
2004 Subject Report	248
2005 Subject Report	263
2007 Subject Report	275
2008 Subject Report (Trinidad and Tobago)	285
2008 Subject Report (Rest of the Caribbean)	291
2009 Subject Report	298
2010 Subject Report	305
2011 Subject Report	313
2013 Subject Report	321
2014 Subject Report	333
2015 Subject Report	340
2018 Subject Report	349

Physics

Physics is the study of nature, conducted in order to understand how the world around us behaves. Physics study matter and its motion, as well as space and time and explores concepts such as force, energy, mass, and charge. The CAPE Physics Syllabus will enable persons to be aware of the laws and theories of Physics that influence every aspect of their physical existence and to acquire understanding and knowledge of technological and scientific application of Physics, especially in the Caribbean context. The CAPE Physics Syllabus is structured to ensure that students become aware of their moral, social, and ethical responsibilities as well as the benefits intrinsic to the practical application of scientific knowledge in careers in the field of science. The syllabus also helps to develop an understanding of the scientific process, its usefulness and its limitations.

This syllabus is arranged into TWO Units, each made up of three Modules.

Unit 1: Mechanics, Waves, Properties of Matter

- Module 1 – Mechanics
- Module 2 – Oscillations and Waves
- Module 3 – Thermal and Mechanical Properties of Matter

Unit 2: Electricity and Magnetism, AC Theory and Atomic and Nuclear Physics

- Module 1 – Electricity and Magnetism
- Module 2 – AC Theory and Electronics
- Module 3 – Atomic and Nuclear Physics



CARIBBEAN
EXAMINATIONS
COUNCIL

Caribbean Advanced
Proficiency Examination®

SYLLABUS

PHYSICS

CXC A16/U2/17

Effective for examinations from May–June 2019



Correspondence related to the syllabus should be addressed to:

The Pro-Registrar
Caribbean Examinations Council
Caenwood Centre
37 Arnold Road, Kingston 5, Jamaica

Telephone Number: + 1 (876) 630-5200
Facsimile Number: + 1 (876) 967-4972
E-mail Address: cxcwzo@cxc.org
Website: www.cxc.org

Copyright ©2017 by Caribbean Examinations Council
Prince Road, Pine Plantation Road, St Michael BB11091

Contents

INTRODUCTION.....	i
RATIONALE.....	1
AIMS.....	2
SKILLS AND ABILITIES TO BE ASSESSED	2
PREREQUISITES OF THE SYLLABUS	5
STRUCTURE OF THE SYLLABUS.....	5
SUGGESTIONS FOR TEACHING THE SYLLABUS.....	5
THE PRACTICAL APPROACH	6
UNIT 1: MECHANICS, WAVES, PROPERTIES OF MATTER	10
MODULE 1: MECHANICS	10
MODULE 2: OSCILLATIONS AND WAVES.....	21
MODULE 3: THERMAL AND MECHANICAL PROPERTIES OF MATTER.....	30
UNIT 2: ELECTRICITY AND MAGNETISM, AC THEORY AND ELECTRONICS AND ATOMIC AND NUCLEAR PHYSICS	40
MODULE 1: ELECTRICITY AND MAGNETISM	40
MODULE 2: AC THEORY AND ELECTRONICS.....	52
MODULE 3: ATOMIC AND NUCLEAR PHYSICS	61
OUTLINE OF ASSESSMENT	70
REGULATIONS FOR PRIVATE CANDIDATES	76
REGULATIONS FOR RESIT CANDIDATES	76
ASSESSMENT GRID.....	77
APPENDIX I: GLOSSARY	78
APPENDIX II: PRACTICAL ACTIVITIES	83
APPENDIX III: LIST OF MINIMUM LABORATORY REQUIREMENTS	98
APPENDIX IV: LIST OF PHYSICAL CONSTANTS	100

APPENDIX V: MATHEMATICAL REQUIREMENTS.....	102
APPENDIX VI: SUMMARY OF KEY QUANTITIES, SYMBOLS AND UNITS.....	105
APPENDIX VII: RESOURCES.....	102

This document CXC A16/U2/17 replaces CXC A16/U2/07 issued in 2007. Please note that the syllabus has been revised and amendments are indicated by italics.

First issued 1999

Revised
2001, 2007, 2017

Please check the website, www.cxc.org for updates on CXC's syllabuses.

Introduction

The Caribbean Advanced Proficiency Examination® (**CAPE**®) is designed to provide certification of the academic, vocational and technical achievement of students in the Caribbean who, having completed a minimum of five years of secondary education, wish to further their studies. The examinations address the skills and knowledge acquired by students under a flexible and articulated system where subjects are organised in 1-Unit or 2-Unit courses with each Unit containing three Modules. Subjects examined under **CAPE**® may be studied concurrently or singly.

The Caribbean Examinations Council offers three types of certification at the **CAPE**® level. The first is the award of a certificate showing each **CAPE**® Unit completed. The second is the **CAPE**® Diploma, awarded to candidates who have satisfactorily completed at least six Units, including Caribbean Studies. The third is the **CXC**® Associate Degree, awarded for the satisfactory completion of a prescribed cluster of eight **CAPE**® Units including Caribbean Studies, Communication Studies and Integrated Mathematics. Integrated Mathematics is not a requirement for the **CXC**® Associate Degree in Mathematics. The complete list of Associate Degrees may be found in the **CXC**® Associate Degree Handbook.

For the **CAPE**® Diploma and the **CXC**® Associate Degree, candidates must complete the cluster of required Units within a maximum period of five years. To be eligible for a **CXC**® Associate Degree, the educational institution presenting the candidates for the award, must select the Associate Degree of choice at the time of registration at the sitting (year) the candidates are expected to qualify for the award. Candidates will not be awarded an Associate Degree for which they were not registered.

Physics Syllabus

◆ RATIONALE

Science plays a major role in the evolution of knowledge. It empowers us to use creative and independent approaches to problem-solving. It arouses our natural curiosity and enables us to meet diverse and ever expanding challenges. It enhances our ability to inquire, seek answers, research, and interpret data. These skills which lead to the construction of hypotheses, theories and laws that help us to explain natural phenomena and exercise control over our environment. Science is, thus, an integral component of a balanced education.

Physics is generally regarded as the most fundamental scientific discipline and forms the basis of many other sciences including Chemistry and Seismology, and can be applied to Biology and Medicine. The study of Physics is necessary to explain our physical environment. In fact, this is the role of the laws and theories of Physics that influence every aspect of our physical existence. In particular, whatever conveniences and luxuries we enjoy as citizens of Caribbean nations can either directly or indirectly be traced to these fundamental physical laws, theories, and new technologies. Physics plays a role in providing the tools for the sustainable development of the Caribbean, in particular, the development of environmentally friendly forms of power generation, monitoring, and modelling of our environment.

The most important natural resource in the Caribbean is its people. If the Caribbean is to play an important role in the new global village and survive economically, a sustained development of the scientific and technological resources of its people is essential. The **CAPE**[®] Physics Syllabus is redesigned with a greater emphasis on the application of scientific concepts and principles. Such an approach is adopted in order to develop those long-term transferrable skills of ethical conduct, team work, problem-solving, critical thinking, innovation, and communication. In addition, it encourages the use of various student-centred teaching-learning strategies and assessment to inculcate these skills, while, at the same time, catering to multiple intelligences and different learning styles and needs. The syllabus will assist students to develop positive values and attitudes towards the physical components of the environment, and will also provide a sound foundation for those who wish to pursue further studies in science.

This syllabus contributes to the development of the Ideal Caribbean Person as articulated by the CARICOM Heads of Government in the following areas: respect for human life; awareness of the importance of living in harmony with the environment; demonstration of multiple literacies; independent and critical thinking and the innovative application of science and technology to problem-solving. Such a person should demonstrate a positive work ethic and value and display creative imagination and entrepreneurship. In keeping with the UNESCO Pillars of Learning, on completion of the study of this course, students will learn to do, learn to be and learn to transform themselves and society.

◆ AIMS

The syllabus aims to:

1. enable students to develop an understanding and knowledge of technological and scientific applications of Physics, especially in the Caribbean context;
2. enable students to demonstrate an understanding of natural phenomena which affect this region and their sensitivity to concerns about the preservation of our environment;
3. encourage the development of rational and ethical attitudes and behaviours in the application of Physics;
4. assist in the development of critical thinking, analytical, and practical skills;
5. provide appropriate scientific training for the purposes of employment, further studies, and personal enhancement;
6. assist in the development of good laboratory skills and in the practice of safety measures when using equipment;
7. enhance an interest in and love for the study of Physics;
8. facilitate the development of the ability to communicate scientific information in a logical and structured manner;
9. develop the ability to work independently and collaboratively with others when necessary;
10. promote an appreciation of the significance and limitations of science in relation to social and economic development; and,
11. promote the integration of Information and Communication Technology (ICT) tools and skills.

◆ SKILLS AND ABILITIES TO BE ASSESSED

The skills students are expected to have developed on completion of this syllabus, have been grouped under three main headings, namely:

1. Knowledge and Comprehension;
2. Use of Knowledge; and,
3. Experimental Skills.

1. Knowledge and Comprehension (KC)

- (a) Knowledge - the ability to identify, remember and grasp the meaning of basic facts, concepts and principles.
- (b) Comprehension - the ability to select appropriate ideas, match, compare and cite examples and principles in familiar situations.

2. Use of Knowledge (UK)

(a) Application

The ability to:

- (i) use facts and apply concepts, principles and procedures in familiar and in novel situations;
- (ii) transform data accurately and appropriately; and,
- (iii) use formulae accurately for computational purposes.

(b) Analysis and Interpretation

The ability to:

- (i) identify and recognise the component parts of a whole and interpret the relationship among those parts;
- (ii) identify causal factors and show how they interact with each other;
- (iii) infer, predict and draw conclusions; and,
- (iv) make necessary and accurate calculations and recognise the limitations and assumptions involved.

(c) Synthesis

The ability to:

- (i) combine component parts to form a new and meaningful whole; and,
- (ii) make predictions and solve problems.

(d) Evaluation

The ability to:

- (i) make reasoned judgements and recommendations based on the value of ideas and information and their implications;
- (ii) analyse and evaluate information from a range of sources to give concise and coherent explanations of scientific phenomena; and,
- (iii) assess the validity of scientific statements, experiments, results, conclusions and inferences.

3. Experimental Skills (XS)

(a) Observation, Recording and Reporting

The ability to:

- (i) make accurate observations and minimise experimental errors;
- (ii) report and recheck unexpected results;
- (iii) select and use appropriate modes of recording data or observations, for example, graphs, tables, diagrams;
- (iv) record observations, measurements, methods and techniques with due regard for precision, accuracy, and units;
- (v) present data in an appropriate manner, using the accepted convention of recording errors and uncertainties;
- (vi) organise and present information, ideas, descriptions and arguments clearly and logically in a complete report, using spelling, punctuation and grammar with an acceptable degree of accuracy; and,
- (vii) report accurately and concisely using scientific terminology and conventions as necessary.

(b) Manipulation and Measurement

The ability to:

- (i) follow a detailed set or sequence of instructions;
- (ii) use techniques, apparatus and materials safely and effectively; and,
- (iii) make observations and measurements with due regard for precision and accuracy.

(c) Planning and Designing

The ability to:

- (i) make predictions, develop hypotheses and devise means of carrying out investigations to test them;
- (ii) plan experimental procedures and operations in a logical sequence within time allocated;
- (iii) use experimental controls where appropriate;
- (iv) modify an original plan or sequence of operations as a result of difficulties encountered in carrying out experiments or obtaining unexpected results;

- (v) take into account possible sources of errors and danger in the design of an experiment; and,
- (vi) select and use appropriate equipment and techniques.

◆ PREREQUISITES OF THE SYLLABUS

Any person with a good grasp of the Caribbean Secondary Education Certificate (**CSEC**[®]) Physics syllabus, or its equivalent, should be able to pursue the course of study defined by this syllabus. However, successful participation in the course of study will also depend on the possession of good verbal and written communication and mathematical skills (see page 103 for mathematical requirements).

◆ STRUCTURE OF THE SYLLABUS

The subject is organised in two (2) Units. A Unit comprises three (3) Modules each requiring fifty (50) hours. The total time for each Unit, is therefore, expected to be one hundred and fifty (150) hours. Each Unit can independently offer students a comprehensive programme of study with appropriate balance between depth and coverage to provide a basis for further study in this field.

Unit 1: Mechanics, Waves, Properties of Matter

Module 1	Mechanics
Module 2	Oscillations and Waves
Module 3	Thermal and Mechanical Properties of Matter

Unit 2: Electricity and Magnetism, A.C. Theory and Electronics and Atomic and Nuclear Physics

Module 1	Electricity and Magnetism
Module 2	A C Theory and Electronics
Module 3	Atomic and Nuclear Physics

It is recommended that of the approximately 50 hours suggested for each Module, a minimum of about 20 hours be spent on laboratory-related activities, such as conducting experiments, making field trips and viewing audio-visual materials.

◆ SUGGESTIONS FOR TEACHING THE SYLLABUS

The organisation of each module in the syllabus is designed to facilitate inquiry-based learning and to ensure that connections among physical concepts are established. Teachers should ensure that their lessons stimulate the use of the senses in learning as this will help students view science as a dynamic and exciting investigative process.

The general and specific objectives indicate the scope of the content including practical work that should be covered. However, unfamiliar situations may be presented as stimulus material in examination questions. Explanatory notes are provided to the right of some specific objectives. These notes provide further guidance to teachers as to the level of detail required. Suggested practical activities indicate those areas of the syllabus that are suitable for practical work. However, practical work should not necessarily be limited to these activities.

This syllabus caters to varying teaching and learning styles, with specific attention being drawn to the interrelatedness of concepts. Whenever possible, a practical approach should be employed, with special attention given to the identification of variables, the use of information gathering technological tools and social networking media to aid investigations and teamwork. The need for good observational, mathematical, data analysis and reporting skills must be emphasised.

While classical Physics is several hundred years old, it is the fundamental discipline responsible for the modern technological era in which we live and a strong appreciation of this must be inculcated by linking the work of the classical scientists to present technological development.

Greater emphasis should be placed on the application of scientific concepts and principles, and less on the factual materials, which encourage memorisation and short-term recall. Opportunities should be provided for relating the study of physical principles to relevant, regional and global examples. The relationship between the theory and practical is to be continually highlighted.

The role of the teacher is to facilitate students' learning of accurate and unbiased information that will contribute to a more scientifically literate society, capable of making educated decisions regarding the world in which we live.

◆ THE PRACTICAL APPROACH

The syllabus is designed to foster the use of inquiry-based learning through the application of the practical approach. Students will be guided to answer scientific questions by a process of making observations, asking questions, doing experiments, and analysing and interpreting data. The **CAPE®** Physics Syllabus focuses on the following skills.

1. Planning and Designing (PD)

Student's ability to:

- (a) Ask questions: how, what, which, why or where. (Students must be guided by their teachers to ask scientific questions).

Example: How does the length of the simple pendulum affect its period of swing?

- (b) Construct a hypothesis: The hypothesis must be clear, concise and testable.

Example: There is direct correlation between the length of the pendulum and period of the swing.

- (c) Design an experiment to test the hypothesis. Experimental report must include the following:

- (i) problem statement;
- (ii) aim;
- (iii) list of materials and apparatus to be used;
- (iv) identification of variables;

- (v) clear and concise step by step procedure;
- (vi) display of expected results;
- (vii) use of results;
- (viii) possible sources of error/precaution; and,
- (ix) possible limitations.

2. Measurement and Manipulation (MM)

- (a) Student's ability to handle scientific equipment competently.

The list of equipment is:

- (i) Bunsen burner;
 - (ii) Vernier callipers;
 - (iii) measuring cylinder;
 - (iv) beakers;
 - (v) thermometer;
 - (vi) ruler;
 - (vii) stop watch/clock;
 - (viii) balance;
 - (ix) micrometer screw gauge;
 - (x) voltmeter;
 - (xi) multimeter; and,
 - (xii) ammeter.
- (b) Student's ability to take accurate measurements.
- (c) Student's ability to use appropriate units.

3. Observation, Reporting and Recording (ORR)

(a) Recording

Student's ability to record observations and to collect and organise data; observations and data may be recorded in:

- (i) Prose
Written description of observations in the correct tense.
- (ii) Table
Numerical: physical quantities with symbols and units stated in heading, significant figures.
- (iii) Graph
Title axes labelled, correct scales, accurate plotting fine points, smooth curves/best fit lines.
- (iv) Calculations
Calculations must be shown with attention paid to units.

(b) Reporting

Student's ability to prepare a comprehensive written report on their assignments using the following format.

- (i) **Date** (date of experiment).
- (ii) **Aim** (what is to be accomplished by doing the experiment).
- (iii) **Apparatus and Materials** (all equipment and materials used in the experiment must be listed).
- (iv) **Method/Experimental Procedure** (step by step procedure written in the past tense).
- (v) **Results and Observations** (see (a) above: Recording).
- (vi) **Discussion**.
- (vii) **Conclusion** (*should be related to the Aim*).

4. Analysis and Interpretation

Student's ability to:

- (a) make accurate calculations;
- (b) identify patterns and trends, cause and effect, and stability and change;
- (c) compare actual results with expected results if they are different;
- (d) identify limitations and sources of error and error ranges if appropriate;
- (e) suggest alternative methods or modification to existing methods; and,
- (f) draw a conclusion justified by data.

◆ **UNIT 1: MECHANICS, WAVES, PROPERTIES OF MATTER**
MODULE 1: MECHANICS

GENERAL OBJECTIVES

On completion of this Module, students should:

1. understand physical quantities;
2. apply the SI system of units and standard conventions;
3. solve problems of bodies at rest, in uniform motion, or uniformly accelerated motion under the influence of forces in one and two dimensions;
4. appreciate the effects of forces acting on a body;
5. understand the principle of conservation of energy;
6. design and carry out experiments to test relationships between physical quantities; and,
7. appreciate that the measurement of a physical quantity is subject to uncertainty.

Please note that Module 1, Specific Objectives 1.1-2.6 which cover Physical Quantities and SI Units are relevant to both Unit 1 and Unit 2.

SPECIFIC OBJECTIVES	EXPLANATORY NOTES	SUGGESTED PRACTICAL ACTIVITIES
---------------------	-------------------	--------------------------------

1. Physical Quantities

Students should be able to:

- | | | |
|------|---|---|
| 1.1. | express physical quantities as a numerical magnitude and unit; | Some quantities are dimensionless, for example, refractive index, relative density. |
| 1.2. | distinguish between scalar and vector quantities, and state examples; | |
| 1.3. | <i>resolve vectors;</i> | Both graphically and by calculation.
The resolution of vectors using strings and masses.
Add and subtract vectors using components.
<i>For example, air and sea travel; flying a kite.</i> |

UNIT 1
MODULE 1: MECHANICS (cont'd)

SPECIFIC OBJECTIVES	EXPLANATORY NOTES	SUGGESTED PRACTICAL ACTIVITIES
---------------------	-------------------	--------------------------------

Physical Quantities (cont'd)

Students should be able to:

- | | | | |
|------|---|---|---|
| 1.4. | measure physical quantities using appropriate instruments; | A practical approach should be used, for example, using a Vernier caliper, screw gauge, multi-meter. | |
| 1.5. | construct calibration curves; | A practical approach can be used. Non-linear curves may be included. Calibration is an operation that, under specific conditions, in a first step, establishes a relation between the quantity values with measurement uncertainties provided by measurement standards and corresponding indications with associated measurement uncertainties. | <i>Calibrate a spring to measure mass or a bottle to measure volume. Use a dropper pipette to get the exact volume. Estimate the volume of an instrument given a portion of a linear scale.</i> |
| 1.6. | <i>use calibration curves;</i> | <i>Use calibration curves to establish a relation for obtaining a measurement result from a reading given by a meter or a gauge. For example, determine the temperature indicated by a thermistor from a calibration curve of temperature versus resistance.</i> | <i>Use calibration curves to determine the volume of water in a container of different orientations.</i> |
| 1.7. | rearrange relationships between physical quantities so that linear graphs may be plotted; | Include logarithmic plots to test exponential and power law variations. | |

UNIT 1
MODULE 1: MECHANICS (cont'd)

SPECIFIC OBJECTIVES	EXPLANATORY NOTES	SUGGESTED PRACTICAL ACTIVITIES
---------------------	-------------------	--------------------------------

Physical Quantities (cont'd)

Students should be able to:

1.8. distinguish between precision and accuracy; and,

A dart board could be used as a practical demonstration of the difference between the two. Or a makeshift dartboard - a circular piece of cardboard and small pieces of modelling clay as the darts.

Practical activity on the distribution of errors in physical measurements. (See Appendix II.)

1.9. estimate the uncertainty in a derived quantity from actual, fractional or percentage uncertainties.

Uncertainties can be combined according to the relationship of the various quantities, for example, addition, subtraction, multiplication and raising to powers.

2. SI Units

Students should be able to:

2.1. state the base quantities including their symbols and SI units;

Mass, length, time, temperature, current, luminous intensity and amount of substance.

2.2. use base quantities or units to obtain expressions for derived quantities or units;

Summary of key quantities, symbols and units on pages 107–109.

2.3. use prefixes and their symbols to express multiples (up to 10^9) and sub-multiples (down to 10^{-12}) of units of base and derived quantities; and,

Solve problems where the indices have to be substituted before calculation.

For example, $C = \frac{6\text{km}}{20\ \mu\text{s}}$

UNIT 1
MODULE 1: MECHANICS (cont'd)

SPECIFIC OBJECTIVES	EXPLANATORY NOTES	SUGGESTED ACTIVITIES	PRACTICAL
---------------------	-------------------	----------------------	-----------

SI Units (cont'd)

Students should be able to:

- 2.4. use base units to check the homogeneity of physical equations.

3. Motions

Students should be able to:

- 3.1. explain displacement, speed, velocity, and acceleration;

- 3.2. use graphs to represent displacement, speed, velocity, and acceleration in a single dimension;

- 3.3. use the gradient of and area under motion graphs to solve problems;

- 3.4. derive equations representing uniformly accelerated motion in a single dimension;

A non-calculus approach may be used:

$$v = u + at$$

$$v^2 = u^2 + 2as$$

$$s = \frac{(u + v)t}{2}$$

$$s = ut + \frac{1}{2}at^2$$

$$s = vt - \frac{1}{2}at^2$$

- 3.5. use the equations of motion to solve problems, on uniformly accelerated motion;

Perform experiments using an object rolled down an inclined plane, for example, a marble rolled down an inclined PVC guttering.

UNIT 1
MODULE 1: MECHANICS (cont'd)

SPECIFIC OBJECTIVES	EXPLANATORY NOTES	SUGGESTED PRACTICAL ACTIVITIES
---------------------	-------------------	--------------------------------

Motions (cont'd)

Students should be able to:

3.6. solve problems involving bodies undergoing projectile motion;	Requires only a non-calculus approach. Consider <i>bodies launched from level ground or from elevation.</i>	<i>Investigate projectile motion using a device or machine such as a cricket bowling machine, trebuchet (catapult) or ballistic pendulum. Additionally, virtual experiments of projectile motion can be explored.</i>
3.7. show that projectile motion is parabolic;	Include both vertical and horizontal projection.	
3.8. state Newton's laws of motion;	An UNBALANCED external force is required to change the velocity.	
3.9. explain 'linear momentum';		
3.10. state the principle of conservation of linear momentum;		
3.11. apply the principle of conservation of linear momentum;	For example, collisions in one or two dimensions, such as in billiards, "explosions" as in the recoil of a gun.	Use Newton's cradle.
3.12. distinguish between inelastic and perfectly elastic collisions;	Collisions should be limited to two objects only.	
3.13. explain the concept of the impulse of a force;		
3.14. use the concept of the impulse of a force;		

UNIT 1
MODULE 1: MECHANICS (cont'd)

SPECIFIC OBJECTIVES	EXPLANATORY NOTES	SUGGESTED PRACTICAL ACTIVITIES
---------------------	-------------------	--------------------------------

Motions (cont'd)

Students should be able to:

3.15.	draw F-t graphs;	For example, car crash.	
3.16.	interpret F-t graphs;		
3.17.	solve problems related to Newton's laws of motion;	Problems should include uniform acceleration only.	Demonstrate: First Law using the <i>coin drop experiment</i> ; Second Law using inclined plane varying mass and recording acceleration or experiment using Atwood's machine; and Third Law using a Balloon Propeller (blow up a balloon).
3.18.	express angular displacement in radians;	<i>For example, the ratio between: arc length of bat lift and bat length with shoulder as centre; arc length of windmill dunk and length of arm with shoulder as centre;</i>	
3.19.	apply the concept of angular velocity to problems involving circular motion;	<i>An observation of road damage in bends or curves due to the provision of centripetal force to provide the circular motion.</i>	
3.20.	use equations for centripetal acceleration and centripetal force;	$a = r\omega^2$ $v=r\omega$ $a = \frac{v^2}{r}$ $F = mr\omega^2$ $F = m\frac{v^2}{r}$	

UNIT 1
MODULE 1: MECHANICS (cont'd)

SPECIFIC OBJECTIVES	EXPLANATORY NOTES	SUGGESTED PRACTICAL ACTIVITIES
---------------------	-------------------	--------------------------------

Motions (cont'd)

Students should be able to:

- | | | |
|-------|--|---|
| 3.21. | use the equations of circular motion to solve problems; | Include working for horizontal circles, vertical circles, conical pendulum and banked circles |
| 3.22. | use Newton's Law of Universal Gravitation in problems involving attraction between masses; | $F = \frac{GM_1M_2}{r^2}$ |
| 3.23. | explain the term gravitational field strengths (at the Earth's surface or above); | $g = \frac{F}{m}$, units for g: Nkg ⁻¹ |
| 3.24. | use the term gravitational field strengths (at the Earth's surface or above); | <i>(Include relationship with height).</i> |
| 3.25. | solve problems involving circular orbits; and, | Include apparent weightlessness. |
| 3.26. | discuss the motion of geostationary satellites and their applications. | Compare with other orbits, for example, those of Global Positioning System (GPS) satellites. |

4. Effects of Forces

Students should be able to:

- | | | | |
|------|--|--|--|
| 4.1. | explain the origin of the upthrust acting on a body wholly or partially immersed in a fluid; | Upthrust due to pressure difference. | See Appendix II for suggested practical activity. |
| 4.2. | explain the nature, cause and effects of resistive forces; | Include drag forces in fluids and frictional forces, <i>and the effects of air</i> | Use a one mass (weight) on the desk attached to a mass hanging off the edge of the desk. |

resistance on rain drops.

UNIT 1

MODULE 1: MECHANICS (cont'd)

SPECIFIC OBJECTIVES	EXPLANATORY NOTES	SUGGESTED PRACTICAL ACTIVITIES
---------------------	-------------------	--------------------------------

Effects of Forces (cont'd)

Students should be able to:

- | | | | |
|------|--|--|---|
| 4.3. | use the concept of terminal velocity to solve problems involving motion through a fluid; | <i>Include Stoke's Law for viscous drag = $6\pi\eta rv$</i> | Use a steel ball bearing in a clear glass tube of clear viscous liquid, for example, glycerine. |
| 4.4. | apply the principle of moments to solve problems; and, | | See Appendix II for suggested practical activity. |
| 4.5. | use the concepts of static and dynamic equilibria to solve problems. | Sum of forces equals zero.
Sum of torques equals zero. | |

5. Conservation of Energy

Students should be able to:

- | | | | |
|------|--|---|--|
| 5.1. | use the concept of work as the product of force and displacement in the direction of the force; | $W = Fx$ | |
| 5.2. | use the formula for kinetic energy $E_k = \frac{1}{2}mv^2$; | A non-calculus approach may be used. | |
| 5.3. | distinguish between different types of potential energy; | Such as gravitational, electrical, elastic and strain energy. | |
| 5.4. | use the formula $\Delta E_p = mg\Delta h$ for potential energy changes near the Earth's surface; | | |
| 5.5. | apply the concept of power as the rate of doing work; | $P = \frac{W}{t}$, also $P = Fv$ | |

UNIT 1
MODULE 1: MECHANICS (cont'd)

SPECIFIC OBJECTIVES	EXPLANATORY NOTES	SUGGESTED PRACTICAL ACTIVITIES
----------------------------	--------------------------	---------------------------------------

Conservation of Energy (cont'd)

Students should be able to:

- | | | | |
|------|--|--|---|
| 5.6. | describe examples of energy conversion; | <i>Examples of different forms of energy and the efficiency of conversion among them. Include examples occurring in industry and in everyday life.</i> | |
| 5.7. | apply the concept of energy conversion to Caribbean situations; and, | Special reference is to be made to non-traditional and renewable sources such as biofuel and ethanol, geothermal, solar, wind and hydro which are applicable to the Caribbean. | Demonstrate using existing system to show energy conversion, for example, solar panel, bio-digester and wind turbine. |
| 5.8. | discuss the mechanisms for the efficient use of energy in the Caribbean. | Emphasis should be on measures which are suited to tropical climates like the Caribbean. | |

UNIT 1

MODULE 1: MECHANICS (cont'd)

Suggested Teaching and Learning Activities

To facilitate students' attainment of the objectives of this Module, teachers are advised to engage students in teaching and learning activities listed below.

1. Allow students to investigate the Physics of the motion of a cricket ball after delivery by bowler, for example, reverse swing.
2. Ask students to investigate factors influencing deviation of a struck cricket ball, or any ball, from an ideal parabolic path. For example, factors such as atmospheric conditions or defects in the ball.
3. Have students investigate the effect of the "follow through" on the motion of struck balls in different ball sports, for example, cricket and tennis.
4. Allow students to design and construct a model for a geostationary satellite.
5. Ask students to design and construct energy conversion models, for example, solar → electricity.
6. Allow students to investigate efficiency of different energy conversion models.
7. Have students investigate useful energy conservation mechanisms applicable to the design and construction of buildings in the Caribbean.
8. *Students could visit an airport or dock to observe landing, positions of wings, approach angles, forward speed and drop speed.*
9. *Observe game of lawn tennis, different actions and positions, and associate movement of ball with projectile motion. Consider the final movement of racquet as a combination of vectors to produce spin.*

UNIT 1

MODULE 1: MECHANICS (cont'd)

RESOURCES

Adams, S. and Allay, J.	Advanced Physics. Oxford: Oxford University Press, 2000.
Breithaupt, J.	Understanding Physics for Advanced Level, 4th Edition. Cheltenham: Nelson Thornes Publishers, 2000.
Crundell, M. and Goodwin, G.	Cambridge International AS and A Level Physics. London: Hodder Education, 2014.
<i>David, T., Crichlow, J., Hunte, C. and Defrietas, D.</i>	<i>Physics for CAPE Unit 1, A CXC® Study Guide. Oxford University Press, 2012.</i>
Dobson, K., Grace, D. and Lovett, D.	Physics, 3rd Edition. London: Harper Collins Publishers, 2008.
Muncaster, Roger.	Advanced Level Physics, 4th Edition. London: Oxford University Press, 2014.

Websites

<http://www.physics.usyd.edu.au/~cross/cricket.html>

<http://physicsofcricket.weebly.com/dynamicskinetics.html>

<http://www.stormthecastle.com/trebuchet/trebuchet-kits.htm>

https://en.wikipedia.org/wiki/Newton%27s_cradle

<https://www.youtube.com/watch?v=0LnbyjOyEQ8>

<http://hyperphysics.phy-astr.gsu.edu/hbase/atwd.html>

www.mathisfun.com/algebra/logarithms

<https://www.google.qy/url?sa=t&source=web&rct=j&url=http://web.uvic.ca/~jalexndr/192UncertRules.pdf&ved=0ahUKEwistOfar5bUAhVI2SYKHDrGAioQFqhbMAw&usq=AFQjCNE1Y28QDdSweNhvtCtvnuTNJsPkOA&sig2=Uhutv TzQggf-bldm85nHA>

<http://www.real-world-physics-problems.com/trebuchet-physics.html>

<http://physicsofcricket.weebly.com>

<http://www.zmescience.com/science/why-dont-rain-drops-kill-you/>

<http://www.sciencedirect.com/science/article/pii/S2095263514000399>

UNIT 1
MODULE 2: OSCILLATIONS AND WAVES

GENERAL OBJECTIVES

On completion of this Module, students should:

1. understand the different types of oscillatory motion;
2. appreciate the properties common to all waves;
3. recognise the unique properties of different types of waves; and,
4. apply their knowledge of waves to the functioning of the eye and the ear.

SPECIFIC OBJECTIVES	EXPLANATORY NOTES	SUGGESTED PRACTICAL ACTIVITIES
----------------------------	--------------------------	---------------------------------------

1. Harmonic Motion

Students should be able to:

- | | | |
|--|---|--|
| <p>1.1. use the equations of simple harmonic motion to solve problems;</p> | $A = -\omega^2 x$ $x = A \sin(\omega t) \text{ or } x = A \cos(\omega t)$ $v = v_0 \cos(\omega t) \text{ or } v = v_0 \sin(\omega t)$ $v^2 = \omega^2 (A^2 - x^2) \text{ and } v_0 = \omega A$ $T = \frac{2\pi}{\omega}$ <p><i>Refer to Hooke's Law. Consider using the projection of uniform circular motion to describe simple harmonic motion.</i></p> | |
| <p>1.2. recall the conditions necessary for simple harmonic motion;</p> | | |
| <p>1.3. describe graphically the changes in displacement, velocity and acceleration during simple harmonic motion;</p> | <p><i>The graphs need to be done with respect to time and displacement.</i></p> | |

UNIT 1

MODULE 2: OSCILLATIONS AND WAVES (cont'd)

SPECIFIC OBJECTIVES	EXPLANATORY NOTES	SUGGESTED PRACTICAL ACTIVITIES
---------------------	-------------------	--------------------------------

Harmonic Motion (cont'd)

Students should be able to:

- | | | | |
|------|---|---|--|
| 1.4. | use the period of the simple pendulum as $T = 2\pi\sqrt{\frac{l}{g}}$ and of the mass on a spring as $T = 2\pi\sqrt{\frac{m}{k}}$; | Include springs joined in series or in parallel. | <i>Determine the period of oscillating systems, for example, the use of vertical and horizontal springs and weights. Use the graphical techniques covered in Specific Objective 1.3 to record results.</i> |
| 1.5. | describe the interchange of kinetic and potential energies of an oscillating system during simple harmonic motion; | Relate displacement-time graphs to the interchange of kinetic energy and potential energy. | Use a water or broom pendulum with sand to demonstrate a displacement-time graph. |
| 1.6. | calculate the energy of a body undergoing simple harmonic motion; | | |
| 1.7. | describe examples of forced oscillations and resonance; | Use graphs to illustrate the effect on the amplitude of oscillations as the frequency approaches the system's natural frequency.

Discussion on how swaying high-rise buildings or skyscrapers are affected by resonance frequencies and the impact on their structural integrity during an earthquake. | |
| 1.8. | discuss cases in which resonance is desirable and cases in which it is not; | | |
| 1.9. | describe damped oscillations and represent such motion graphically; and, | Pay particular attention to the levels of damping and the importance of critical damping. | |

UNIT 1

MODULE 2: OSCILLATIONS AND WAVES (cont'd)

SPECIFIC OBJECTIVES	EXPLANATORY NOTES	SUGGESTED PRACTICAL ACTIVITIES
---------------------	-------------------	--------------------------------

Harmonic Motion (cont'd)

Students should be able to:

- | | | |
|-------|---|---|
| 1.10. | explain how damping is achieved in some real-life examples. | Use examples such as motor vehicle suspension, rally car driving, <i>analogue electrical meters and door closures</i> . |
|-------|---|---|

2. Properties of Waves

Students should be able to:

- | | | |
|------|--|--|
| 2.1. | use the following terms: displacement, amplitude, period, frequency, velocity in relation to the behaviour of waves; | Explanation through the use of graphs and sketches. |
| 2.2. | differentiate between transverse and longitudinal mechanical waves; | Explanation of the movement of particles in the medium of transmission and the energy of the waves. Use virtual labs (PhET Suite). |
| 2.3. | represent transverse and longitudinal waves graphically; | |
| 2.4. | explain "polarisation"; | <i>Give examples of polarised waves.</i> |
| 2.5. | use the equation $v = f\lambda$ to solve problems involving wave motion; | |
| 2.6. | use the relationship intensity is proportional to (amplitude) ² for a wave; | $I \propto A^2$ |

UNIT 1

MODULE 2: OSCILLATIONS AND WAVES (cont'd)

SPECIFIC OBJECTIVES	EXPLANATORY NOTES	SUGGESTED PRACTICAL ACTIVITIES
---------------------	-------------------	--------------------------------

Properties of Waves (cont'd)

Students should be able to:

- | | | |
|-------|--|---|
| 2.7. | use the terms phase, and phase difference with reference to behaviour of waves; | |
| 2.8. | distinguish between stationary and progressive waves; | Explanation of nodes and anti-nodes. |
| 2.9. | explain the properties of stationary waves and perform related calculations; | For example, microwaves, waves on strings, closed and open pipes (include resonance tube).
See Appendix II for suggested practical activity. |
| 2.10. | describe practical applications of sound waves in industry; | Use of sonar waves in determining the depth of the sea, and in medicine, such as in foetal imaging. |
| 2.11. | discuss application of sound waves to musical instruments; | Include percussion instruments such as the steel pan; stringed instruments such as the guitar; and wind instruments such as the flute. |
| 2.12. | apply the laws of reflection and refraction to the behaviour of waves; | |
| 2.13. | describe experiments to demonstrate diffraction of waves in both narrow and wide gaps; | Use a ripple tank together with both narrow and wide gaps, microwaves, lasers. Use virtual labs to demonstrate diffraction. |
| 2.14. | explain the meaning of coherence as applied to waves; | |

UNIT 1

MODULE 2: OSCILLATIONS AND WAVES (cont'd)

SPECIFIC OBJECTIVES	EXPLANATORY NOTES	SUGGESTED PRACTICAL ACTIVITIES
---------------------	-------------------	--------------------------------

Properties of Waves (cont'd)

Students should be able to:

- | | | |
|-------|--|---|
| 2.15. | explain the terms superposition and interference of waves; | |
| 2.16. | state the conditions necessary for two-source interference fringes of waves to be observed; | Use a simple Young's slit interference experiment for light or microwaves and two speakers for sound. |
| 2.17. | discuss the principles of interference and diffraction as applied to waves; | Constructive and destructive interference. |
| 2.18. | use the approximation $y = \frac{\lambda D}{a}$ to solve problems; | |
| 2.19. | use the expression $n\lambda = a \sin(\theta)$ for interference and diffraction (a=slit spacing); | For two-source interference and for diffraction grating (a=slit spacing). |
| 2.20. | use the diffraction grating to determine the wavelength and frequency of light waves; | Use the same activity for Specific Objective 2.16. |
| 2.21. | discuss the nature of light as electromagnetic radiation with reference to its diffractive properties; | |
| 2.22. | list the orders of magnitude of the wavelengths of the e-m spectrum; | Include range of wavelengths of visible light. |

UNIT 1

MODULE 2: OSCILLATIONS AND WAVES (cont'd)

SPECIFIC OBJECTIVES	EXPLANATORY NOTES	SUGGESTED PRACTICAL ACTIVITIES
---------------------	-------------------	--------------------------------

Properties of Waves (cont'd)

Students should be able to:

- | | | |
|-------|--|--|
| 2.23. | define refractive index in terms of velocity of waves; | See Appendix II for suggested practical activity. |
| 2.24. | use Snell's Law; | $n_1 \sin(\theta_1) = n_2 \sin(\theta_2)$ |
| 2.25. | explain total internal reflection; | Use two media with indices n_1 and n_2 .
Use same suggested practical activity for Specific Objective 2.23. |
| 2.26. | determine the value of critical angle; and, | |
| 2.27. | discuss practical applications of total internal reflection. | For example, fibre optic cables. |

3. Physics of the Ear and Eye

Students should be able to:

- | | | |
|------|---|---|
| 3.1. | discuss the response of the ear to incoming sound waves; | Consider sensitivity, frequency response and intensity. Precise numerical values related to the response of the ear are not required.

Download and use an audiometer to demonstrate the difference in hearing thresholds for individuals. Focus on the change in thresholds with age.

Play high frequency tones above 10 kHz to check whether all individuals can hear. |
| 3.2. | state the orders of magnitude of the threshold of hearing and the intensity at which discomfort is experienced; | |

UNIT 1

MODULE 2: OSCILLATIONS AND WAVES (cont'd)

SPECIFIC OBJECTIVES	EXPLANATORY NOTES	SUGGESTED PRACTICAL ACTIVITIES
---------------------	-------------------	--------------------------------

Physics of the Ear and Eye (cont'd)

Students should be able to:

3.3.	use the equation intensity level in dB = $10 \log_{10}(I/I_0)$;	I = intensity I_0 = threshold intensity dBA scale	
3.4.	discuss the subjective qualities of the terms 'noise' and 'loudness';		
3.5.	solve problems using lens formulae;	$\frac{1}{u} + \frac{1}{v} = \frac{1}{f}$ Power in dioptres = $\frac{1}{f}$ with f in metres.	<i>Determine the focal length of a lens.</i>
3.6.	discuss how the eye forms focused images of objects at different distances;		
3.7.	explain the terms: (a) depth of focus; (b) accommodation; (c) long sight; (d) short sight; (e) astigmatism; and, (f) cataracts;	Calculations on power of correcting lens required.	<i>Investigate depth of focus by applying the lens formulae by keeping one constant and varying the other.</i>
3.8.	discuss how defects of the eye can be corrected; and,		
3.9.	discuss the formation of focused images in the simple camera and magnifying glass.		

UNIT 1

MODULE 2: OSCILLATIONS AND WAVES (cont'd)

Suggested Teaching and Learning Activities

To facilitate students' attainment of the objectives of this Module, teachers are advised to engage students in teaching and learning activities listed below.

1. Ask students to conduct research on how light is transmitted along an optical fibre. Students could investigate the effect of fibre thickness on reduction of light intensity of a specific frequency or the effect of the light frequency on loss in intensity for the identical fibre.
2. Have students construct a model of an electricity generator that can be powered by the energy of sea waves.
3. Ask students to construct a model of an "invisible" aircraft similar to the stealth aircraft which is constructed to be invisible to radar waves. In the stealth aircraft flat panels are angled so as to reflect incident radar signals up or down rather than back to the radar station.
4. Ask students to construct a model of the eye that demonstrates its operation and common defects. A simple laser pointer could be used as the light source.
5. Allow students to investigate the factors influencing the quality of notes produced through the vibration of waves in strings and pipes.
6. Have students investigate the use of ultrasonic waves in cleaning jewellery and teeth.
7. Allow students to investigate the use of ultrasonic waves in medicine.
8. Ask students to conduct research on the use of sonar waves.
9. Ask students to investigate the use of ultrasonics in systems, such as alarms.
10. Have students measure the frequency response of the ear with respect to gender and age.
11. Allow students to measure the "noise" in different locations, for example, factories, airports, classrooms.
12. Ask students to gather information and present data on seismographs.
13. Allow students to investigate the design of speaker boxes and musical instruments.
14. Ask students to measure the 'reverberation time' in a place, such as an auditorium, church or classroom.
15. Have students investigate damping in shock absorbers, car mufflers, acoustic tiles.
16. Invite guest lecturers to discuss the importance of damping.

UNIT 1

MODULE 2: OSCILLATIONS AND WAVES (cont'd)

RESOURCES

- | | |
|---|---|
| Adams, S. and Allay, J. | Advanced Physics. Oxford: Oxford University Press, 2000. |
| Breithaupt, J. | Understanding Physics for Advanced Level, 4th Edition. Cheltenham: Nelson Thornes Publishers, 2000. |
| Crundell, M. and Goodwin, G. | Cambridge International AS and A Level Physics. London: Hodder Education, 2014. |
| <i>David, T., Crichlow, J., Hunte, C. and Defrietas, D.</i> | <i>Physics for CAPE Unit 1, A CXC® Study Guide. Oxford University Press, 2012.</i> |
| Dobson, K., Grace, D. and Lovett, D. | Physics, 3rd Edition. London: Harper Collins Publishers, 2008. |
| Muncaster, R. | Advanced Level Physics, 4th Edition. London: Nelson Thornes Publishers, 1993. |

Websites

<https://www.youtube.com/watch?v=s2ZJEOrmZ2c>

<https://www.youtube.com/watch?v=j-zczJXSxnw>

<https://www.youtube.com/watch?v=lrewnzQYrPI>

UNIT 1

MODULE 3: THERMAL AND MECHANICAL PROPERTIES OF MATTER

GENERAL OBJECTIVES

On completion of this Module, students should:

1. understand the principles involved in the design and use of thermometers;
2. be aware of the thermal properties of materials and their practical importance in everyday life;
3. understand the various modes of heat transfer;
4. be familiar with the kinetic theory of gases and the equation of state of an ideal gas;
5. display a working knowledge of the first law of thermodynamics; and,
6. be aware of the mechanical properties of materials and their practical importance in everyday life.

SPECIFIC OBJECTIVES

EXPLANATORY NOTES

SUGGESTED PRACTICAL ACTIVITIES

1. Design and Use of Thermometers

Students should be able to:

- 1.1. discuss how a physical property may be used to measure temperature;

Include both linear and non-linear variation with temperature.

$$\theta = \frac{X_{\theta} - X_0}{X_{100} - X_0} \times 100$$

Use equation for temperature values on the Empirical scale.

Explanation of the reason why different thermometers when using the Empirical centigrade scale do not agree.

Calibrate a thermometer using a ruler using the following points: steam point, ice point and water at room temperature.

Plot a calibration graph (resistance vs temperature for a thermistor with a negative temperature coefficient.

- 1.2. describe the features of physical specific thermometers;

Liquid-in-glass, resistance (including thermistor), thermocouple and constant volume gas thermometer.

Show students different types of thermometers.

UNIT 1

MODULE 3: THERMAL AND MECHANICAL PROPERTIES OF MATTER (cont'd)

SPECIFIC OBJECTIVES	EXPLANATORY NOTES	SUGGESTED ACTIVITIES	PRACTICAL
---------------------	-------------------	----------------------	-----------

Design and Use of Thermometers (cont'd)

Students should be able to:

1.3. discuss the advantages and disadvantages of these thermometers; and, *Give typical situations where the different types of thermometers will be best suited, based on their particular advantages.*

1.4. recall that the absolute thermodynamic scale of temperature does not depend on the property of any particular substance. *Discussion on absolute zero and the triple point of water (0.01°C).*

Discussion on the conversion of °C to K
 $\vartheta/^{\circ}\text{C} = T/\text{K} - 273.15$

Use the equation

$$T = \frac{P_T}{P_{tr}} \times 273.16$$

2. Thermal Properties

Students should be able to:

2.1. express the internal energy of a system as the sum of the kinetic and potential energies associated with the molecules of the system;

2.2. relate a rise in temperature to an increase in internal energy;

2.3. explain the terms 'heat capacity' and 'specific heat capacity';

UNIT 1

MODULE 3: THERMAL AND MECHANICAL PROPERTIES OF MATTER (cont'd)

SPECIFIC OBJECTIVES	EXPLANATORY NOTES	SUGGESTED PRACTICAL ACTIVITIES
---------------------	-------------------	--------------------------------

Thermal Properties (cont'd)

Students should be able to:

- | | | | |
|------|--|---|---|
| 2.4. | perform experiments to determine the specific heat capacity of liquids and metals by electrical methods and by the method of mixtures; | Both electrical methods and the method of mixtures are to be covered.
<i>The Callender and Barnes continuous flow calorimeter for finding specific heat capacity of a liquid can be discussed. Mention that the main advantage is that the heat capacity of the apparatus itself need not be known. Calculations involving this method should be done.</i> | |
| 2.5. | explain the concepts of 'melting' and 'boiling' in terms of energy input with no change in temperature; | | Find freezing or melting points and boiling points using graphs of temperature against time. |
| 2.6. | relate the concepts of melting and boiling to changes in internal potential energy; | | |
| 2.7. | discuss how specific latent heat of a fluid affects heat transfer during mixing; | Explanation of the term 'specific latent heat'.

Both electrical methods and the method of mixtures are to be covered. | Perform experiments to determine the specific latent heats.
<i>Use a calorimeter (for example, a styrofoam cup) to demonstrate latent heats.</i>
<i>See Appendix 11 for suggested practical activity.</i> |
| 2.8. | explain the cooling which accompanies evaporation; and, | This should be done in terms of latent heat and in terms of the escape of molecules with high kinetic energy. | |

UNIT 1

MODULE 3: THERMAL AND MECHANICAL PROPERTIES OF MATTER (cont'd)

SPECIFIC OBJECTIVES	EXPLANATORY NOTES	SUGGESTED ACTIVITIES	PRACTICAL
---------------------	-------------------	----------------------	-----------

Thermal Properties (cont'd)

Students should be able to:

- 2.9. solve numerical problems using the equations
 $E_H = mc\Delta\theta$ and $E_H = mL$.

3. Heat Transfer

Students should be able to:

- 3.1. describe the mechanism of thermal conduction; *Discussion on why solids are generally better conductors of heat than liquids and gases.*
- 3.2. use the equation $\left(\frac{Q}{t} = -kA\frac{\Delta\theta}{\Delta x}\right)$ to solve problems in one-dimensional heat flow; Restrict use to cases of one-dimensional heat flow. *Use a thermocouple to measure the temperature difference across a lagged bar.*
Temperature gradient = $-\frac{\Delta\theta}{\Delta x}$
- 3.3. solve numerical problems involving composite conductors; Use of concept of equivalent conductor.
- 3.4. discuss the principles involved in the determination of thermal conductivity of good and bad conductors; *Discussion on both Searle's bar and Lee's disc.* Use Searle's apparatus.
- 3.5. explain the process of convection as a consequence of a change of density; Use this concept to explain ocean currents and winds.
- 3.6. discuss thermal radiation;

UNIT 1

MODULE 3: THERMAL AND MECHANICAL PROPERTIES OF MATTER (cont'd)

SPECIFIC OBJECTIVES	EXPLANATORY NOTES	SUGGESTED ACTIVITIES	PRACTICAL
---------------------	-------------------	----------------------	-----------

Heat Transfer (cont'd)

Students should be able to:

- | | | | |
|-------|--|--|--|
| 3.7. | solve problems using Stefan's equation; | <i>For a black body $P = \sigma AT^4$
Include net rate of radiation.
$P = \sigma A(T_1^4 - T_2^4)$</i> | |
| 3.8. | <i>relate Stefan's equation to the greenhouse effect and to climate change;</i> | <i>The greenhouse effect caused by re-radiation of energy from the earth.</i> | |
| 3.9. | discuss applications of the transfer of energy by conduction, convection and radiation; and, | Include vacuum flasks and solar water heaters <i>and other examples.</i> | |
| 3.10. | discuss the development of heating and cooling systems to reduce the Caribbean dependency on fossil fuels. | Discussion on improving the design of a building to take advantage of natural resources and reduce dependence on fossil fuels. | |

4. The Kinetic Theory of Gases

Students should be able to:

- | | | | |
|------|---|--|--|
| 4.1. | use the Avogadro constant (the number of atoms in 0.012 kg of the C-12 isotope) as a numerical entity; | | |
| 4.2. | use the concept of the mole as the quantity of substance containing a number of particles equal to the Avogadro constant; | | |
| 4.3. | use the equation of state for an ideal gas expressed as $pV = nRT$ and $pV = NkT$; | | |

UNIT 1

MODULE 3: THERMAL AND MECHANICAL PROPERTIES OF MATTER (cont'd)

SPECIFIC OBJECTIVES	EXPLANATORY NOTES	SUGGESTED ACTIVITIES	PRACTICAL
---------------------	-------------------	----------------------	-----------

The Kinetic Theory of Gases (cont'd)

Students should be able to:

- | | | | |
|------|---|--|--|
| 4.4. | discuss the basic assumptions of the kinetic theory of gases; | | |
| 4.5. | explain how molecular movement is responsible for the pressure exerted by a gas; | | |
| 4.6. | <i>solve problems using the equation</i>
$pV = \frac{1}{3}Nm\overline{c^2}$; | <i>Use the equation</i>
$p = \frac{1}{3}\rho \langle c^2 \rangle$. | |
| 4.7. | use $pV = \frac{1}{3}Nm\overline{c^2}$ to deduce the equation for the average translational kinetic energy of monatomic molecules; and, | Include calculations of r.m.s. speed,
$\sqrt{\overline{c^2}}$ or $\sqrt{\langle c^2 \rangle}$
$E_k = 3/2 kT$ | |
| 4.8. | deduce total kinetic energy of a monatomic gas. | Total kinetic energy:
$E_k = \frac{3}{2}nRT$ | |

5. First Law of Thermodynamics

Students should be able to:

- | | | | |
|------|---|---|--|
| 5.1. | use the term 'molar heat capacity'; | $E_h = nC_v\Delta\theta$ or
$E_h = nC_p\Delta\theta$ | |
| 5.2. | discuss why the molar heat capacity of a gas at constant volume is different from that of a gas at constant pressure; | $C_p = C_v + R$
<i>Discuss why $C_p > C_v$</i> | |
| 5.3. | calculate the work done on a gas using the equation $W = p\Delta V$; | <i>Distinguish between work done on gas during a compression and work done by gas in expanding.</i> | |

UNIT 1

MODULE 3: THERMAL AND MECHANICAL PROPERTIES OF MATTER (cont'd)

SPECIFIC OBJECTIVES	EXPLANATORY NOTES	SUGGESTED PRACTICAL ACTIVITIES
---------------------	-------------------	--------------------------------

First Law of Thermodynamics (cont'd)

Students should be able to:

- 5.4. deduce work done from a p-V graph; *Draw graphs and find work done with the different types of systems, that is, isothermal, isobaric, isochoric, adiabatic.*
- 5.5. express the first law of thermodynamics; and Change in internal energy, the heat supplied to the system, and the work done on the system.
 $\Delta U = \Delta Q + \Delta W$
- 5.6. solve problems involving the first law of thermodynamics.

6. Mechanical Properties of Materials

Students should be able to:

- 6.1. explain the terms:
(a) density; and
(b) pressure;
- 6.2. use the equations $p = \frac{F}{A}$ and $\rho = \frac{m}{V}$ to solve problems;
- 6.3. derive the equation $\Delta p = \rho g \Delta h$
 $p = \frac{F}{A}$ and $\rho = \frac{m}{V}$ for the pressure difference in a liquid; *Playing football at high altitude.*
- 6.4. use the equation $\Delta p = \rho g \Delta h$ to solve problems;

UNIT 1

MODULE 3: THERMAL AND MECHANICAL PROPERTIES OF MATTER (cont'd)

SPECIFIC OBJECTIVES	EXPLANATORY NOTES	SUGGESTED PRACTICAL ACTIVITIES
---------------------	-------------------	--------------------------------

Mechanical Properties of Materials (cont'd)

Students should be able to:

- | | | |
|-------|---|--|
| 6.5. | relate the difference in the structures and densities of solids, liquids and gases to simple ideas of the spacing, ordering, and motion of their molecules; | |
| 6.6. | describe a simple kinetic model for the behaviour of solids, liquids and gases; | |
| 6.7. | distinguish between the structure of crystalline and non-crystalline solids; | Make particular reference to metals, polymers and glasses. |
| 6.8. | discuss the stretching of springs and wire in terms of load extension; | Hooke's law.
Spring constant. |
| 6.9. | use the relationship among 'stress', 'strain' and 'the Young modulus' to solve problems; | <i>Definitions of stress and strain and Young modulus</i>
$E = \frac{\text{stress}}{\text{strain}}$ and $E = \frac{Fl}{Ae}$. |
| 6.10. | perform experiments to determine the Young modulus of a metal in the form of a wire; | |
| 6.11. | perform experiments based on knowledge of the force-extension graphs for typical ductile, brittle and polymeric materials; | For example, copper, glass, rubber. |
| 6.12. | deduce the strain energy in a deformed material from a force-extension graph; | See Appendix II for suggested practical activity. |

UNIT 1

MODULE 3: THERMAL AND MECHANICAL PROPERTIES OF MATTER (cont'd)

SPECIFIC OBJECTIVES

EXPLANATORY NOTES

SUGGESTED PRACTICAL ACTIVITIES

Mechanical Properties of Materials (cont'd)

Students should be able to:

- | | | | |
|-------|--|--|---------------------------------|
| 6.13. | distinguish between elastic and inelastic deformations of a material; and, | Only qualitative knowledge is required. | Use the same activity as above. |
| 6.14. | discuss the importance of elasticity in structures. | Consider what happens to tall buildings, bridges, and bones when large forces are applied. | |

Suggested Teaching and Learning Activities

To facilitate students' attainment of the objectives of this Module, teachers are advised to engage students in teaching and learning activities listed below.

1. Have students investigate how three different physical properties vary with temperature.
2. Allow students to investigate the suitability of using iron, copper or aluminum as the metal for making an engine block.
3. Allow students to investigate the heat flow through different materials of the same thickness and recommend the use of one in the construction industry, for example, brick, concrete, glass and wood.
4. Ask students to investigate this statement: heat flow in textiles can occur by all three methods of heat transfer, but for metals only conduction is possible.
5. Allow students to investigate the effect of greenhouse gases on global warming.
6. Allow students to investigate heat transfer processes in the solar water heater.
7. Ask students to construct a model of a solar crop dryer.
8. Ask students to construct a model of a solar air conditioner.
9. Allow students to construct a model of a solar still.
10. Have students construct a model of a solar refrigerator.

UNIT 1

MODULE 3: THERMAL AND MECHANICAL PROPERTIES OF MATTER (cont'd)

11. Ask students to investigate the role of thermodynamics in the operation of the four-stroke petrol engine.
12. Ask students to investigate the uses of crystalline and non-crystalline solids in the semiconductor industry.
13. Allow students to investigate the uses of polymers and glasses.
14. Allow students to investigate force-extension graphs for metal wires, glass fibres and rubber.
15. Ask students to design a model structure or building to take advantage of natural resources and reduce dependence on fossil fuels.

RESOURCES

Adams, S. and Allay, J.	Advanced Physics. Oxford: Oxford University Press, 2000.
Breithaupt, J.	Understanding Physics for Advanced Level, 4th Edition. Cheltenham: Nelson Thornes Publishers, 2000.
Crundell, M. and Goodwin, G.	Cambridge International AS and A Level Physics. London: Hodder Education, 2014.
<i>David, T., Crichlow, J., Hunte, C. and Defrietas, D.</i>	<i>Physics for CAPE Unit 1, A CXC® Study Guide. Oxford University Press, 2012.</i>
Dobson, K., Grace, D. and Lovett, D.	Physics, 3rd Edition. London: Harper Collins Publishers, 2008.
Muncaster, R.	Advanced Level Physics, 4th Edition. London: Nelson Thornes Publishers, 1993.

Websites

<https://www.youtube.com/watch?v=rjht4oABYCI&list=PLBu4cfksLjchp4fayfTcOoOHK8DQ5Izqr>

<https://www.youtube.com/watch?v=VRvVnf3noqU>

<https://www.youtube.com/watch?v=H7ArcaFf41Q>

◆ **UNIT 2: ELECTRICITY AND MAGNETISM, AC THEORY AND ELECTRONICS AND ATOMIC AND NUCLEAR PHYSICS**
MODULE 1: ELECTRICITY AND MAGNETISM

GENERAL OBJECTIVES

On completion of this Module, students should:

1. understand electrostatic phenomena;
2. understand electrical quantities and the relationships among them;
3. analyse circuits with various electrical components;
4. understand the concept of electric fields;
5. be aware of the design and use of capacitors;
6. demonstrate a conceptual understanding of magnetic fields;
7. understand how magnetic forces arise; and,
8. demonstrate a working knowledge of electromagnetic phenomena.

Please note that Unit 1, Module 1, Specific Objectives 1.1-2.6 which cover Physical Quantities and SI Units are relevant to Unit 2.

SPECIFIC OBJECTIVES	EXPLANATORY NOTES	SUGGESTED PRACTICAL ACTIVITIES
---------------------	-------------------	--------------------------------

1. Electrical Quantities

Students should be able to:

- 1.1. use the equations $Q = It$ and $Q = \pm Ne$ (N refers to number of charges) to solve problems;
- 1.2. define the 'Coulomb';
- 1.3. define *potential difference* and the 'Volt';
- 1.4. use the equation $V = W/Q$ to solve problems;
- 1.5. use the equation $V = IR$ to solve problems;

UNIT 2
MODULE 1: ELECTRICITY AND MAGNETISM (cont'd)

SPECIFIC OBJECTIVES	EXPLANATORY NOTES	SUGGESTED PRACTICAL ACTIVITIES
---------------------	-------------------	--------------------------------

Electrical Quantities (cont'd)

Students should be able to:

- | | | |
|--|---|--|
| 1.6. use the equations
$P = IV, P = I^2R, P = V^2/R$
to solve problems; | | |
| 1.7. use the formula
$R = \frac{\rho L}{A}$
to determine resistivity; | Definition of resistivity. | Determine the resistance of wire at varying points and plot a graph of resistance versus length. |
| 1.8. use energy considerations to distinguish between e.m.f. and p.d.; | Include the observation that e.m.f. is associated with sources or active devices whereas p.d. is used in reference to an electric field or passive device. | |
| 1.9. explain drift velocity (v) in terms of the charge carriers; | | |
| 1.10. derive the equation $I = nqvA$ for charges moving in a metal (n = charge density); and | | |
| 1.11. use the equation $I = nqvA$ for charges moving in a metal (n = charge density). | Since a similar equation describes the flow of particles in uniform channels, candidates should be able to apply such equations to semiconductors and electrolytes. | |

UNIT 2

MODULE 1: ELECTRICITY AND MAGNETISM (cont'd)

SPECIFIC OBJECTIVES	EXPLANATORY NOTES	SUGGESTED PRACTICAL ACTIVITIES
2. <u>Electrical Circuits</u>		
Students should be able to:		
2.1. compare Ohmic and non-Ohmic devices using an IV graph;	Explanation of these characteristics in terms of the variation in resistance of the device.	Sketch the I - V characteristic for a metallic conductor at constant temperature, a semiconductor diode, and a filament lamp.
2.2. sketch the variation of resistance with temperature for a thermistor with negative temperature coefficient;	Also include different types of thermistors and discuss the differences between the R – T characteristics.	
2.3. solve problems involving terminal p.d. and external load, given that sources of e.m.f. possess internal resistance;	Use examples of different types of source, for example, primary and secondary chemical cells, solar cells, generators.	Determine resistance of small battery or small solar cell.
2.4. draw circuit diagrams;		
2.5. interpret circuit diagrams;	<i>Consider d.c. circuits involving sources of e.m.f. and resistive circuit elements.</i>	
2.6. apply Kirchhoffs laws to given circuits;	Consider d.c. circuits involving sources of e.m.f. and resistive circuit elements. Kirchhoff's First Law is a consequence of conservation of charge and Kirchhoff's Second Law, a consequence of conservation of energy.	
2.7. derive the formula for the effective resistance of two or more resistors in series or parallel;		

UNIT 2

MODULE 1: ELECTRICITY AND MAGNETISM (cont'd)

SPECIFIC OBJECTIVES	EXPLANATORY NOTES	SUGGESTED PRACTICAL ACTIVITIES
---------------------	-------------------	--------------------------------

Electrical Circuits (cont'd)

Students should be able to:

- | | | | |
|-------|--|--|---|
| 2.8. | use the formula for two or more resistors in series or parallel; | | |
| 2.9. | use the potential divider as a source of variable and fixed p.d.; and, | <i>Introduce students to a metre-bridge, for example, potentiometer.</i> | Construct potential divider to provide both variable and fixed p.d. |
| 2.10. | use the Wheatstone bridge as a means of comparing resistances. | Treat as a double potential divider. | Use the Wheatstone bridge to determine unknown resistance. |

3. Electric Fields

Students should be able to:

- | | | |
|------|--|---|
| 3.1. | explain the difference between electrical conductors and insulators; | An electron model should be used in the explanation. |
| 3.2. | use Coulomb's Law: $F = \frac{Q_1 Q_2}{4\pi\epsilon_0 r^2}$ to calculate the force between charges in free space or air to solve problems; | Consider combinations of charges in very simple arrangements. Use a vector approach to determine the resultant force on a single point charge due to other point charges. |
| 3.3. | use $E = \frac{Q}{4\pi\epsilon_0 r^2}$ for the field strength due to a point charge; | E is a vector. |
| 3.4. | calculate the field strength of the uniform field between charged parallel plates; | Consider potential difference and separation of the plates. $E = \frac{V}{d}$ |

UNIT 2

MODULE 1: ELECTRICITY AND MAGNETISM (cont'd)

SPECIFIC OBJECTIVES	EXPLANATORY NOTES	SUGGESTED PRACTICAL ACTIVITIES
---------------------	-------------------	--------------------------------

Electric Fields (cont'd)

Students should be able to:

- | | | |
|-------|---|--|
| 3.5. | calculate the force on a charged particle in a uniform electric field; | $F = EQ$ |
| 3.6. | describe the effect of a uniform electric field on the motion of charged particles; | Consider motions perpendicular and parallel to the electric field. |
| 3.7. | solve numerical problems involving the motion of charged particles in a uniform electric field; | |
| 3.8. | compare the motion of charged particles in a uniform electric field to that of a projectile in a gravitational field; | |
| 3.9. | use the fact that the field strength at a point is numerically equal to the potential gradient at that point; | Consider the uniform electric field and by determining the work done per unit charge, verify this relationship. Refer to Specific Objective 3.7. |
| 3.10. | use the equation $V = \frac{Q}{4\pi\epsilon_0 r}$ for the potential due to a point charge; and, | Compare the potential due to a point charge with that due to a charged sphere of radius r . V is a scalar. |
| 3.11. | find the potential at a point due to several charges. | Compare with vector addition in Specific Objectives 3.5 and 3.6. |

UNIT 2

MODULE 1: ELECTRICITY AND MAGNETISM (cont'd)

SPECIFIC OBJECTIVES	EXPLANATORY NOTES	SUGGESTED PRACTICAL ACTIVITIES
4. <u>Capacitors</u>		
Students should be able to:		
4.1. define capacitance;		
4.2. use the equation $C = \frac{Q}{V}$ to solve problems;		
4.3. use the formula $C = \frac{\epsilon A}{d}$;	$C = \frac{\epsilon_r \epsilon_0 A}{d}$ ϵ_r – relative permittivity or dielectric constant ϵ_0 – permittivity of free space. Refer to the use of dielectrics to produce capacitors of larger values with the same dimensions. Mention the types of dielectrics and the range of their dielectric constants or relative permittivity.	
4.4. derive formulae for capacitors in parallel and series to solve problems;		
4.5. use formulae for capacitors in parallel and series to solve problems;	Include problems on equivalent capacitance for simple series parallel combinations.	
4.6. use the formulae for energy stored in a capacitor as $W = \frac{CV^2}{2}, W = \frac{QV}{2}$ and $W = \frac{Q^2}{2C}$ to solve problems;	<i>Discussion on the mechanism of energy storage in a capacitor.</i>	

UNIT 2

MODULE 1: ELECTRICITY AND MAGNETISM (cont'd)

SPECIFIC OBJECTIVES	EXPLANATORY NOTES	SUGGESTED PRACTICAL ACTIVITIES
---------------------	-------------------	--------------------------------

Capacitors (cont'd)

Students should be able to:

- 4.7. recall the equations for capacitor charge and discharge;

$$Q = Q_0 \exp\left(\frac{-t}{RC}\right)$$

$$Q = Q_0 \left(1 - \exp\left(\frac{-t}{RC}\right)\right)$$

$$I = I_0 \exp\left(\frac{-t}{RC}\right)$$

$$I = I_0 \left(1 - \exp\left(\frac{-t}{RC}\right)\right)$$

$$V = V_0 \exp\left(\frac{-t}{RC}\right)$$

$$V = V_0 \left(1 - \exp\left(\frac{-t}{RC}\right)\right)$$

(RC is the "time constant" and measured in seconds.)

- 4.8. use the equations for capacitor charge and discharge; and,

- 4.9. sketch graphs illustrating the charge and discharge of a capacitor. Q, V or I against t.

5. Magnetic Fields

Students should be able to:

- 5.1. explain 'magnetic flux density' and the 'tesla';

- 5.2. sketch magnetic flux patterns due to a long straight wire, a flat circular coil and a long solenoid; and,

UNIT 2

MODULE 1: ELECTRICITY AND MAGNETISM (cont'd)

SPECIFIC OBJECTIVES	EXPLANATORY NOTES	SUGGESTED PRACTICAL ACTIVITIES
---------------------	-------------------	--------------------------------

Magnetic Fields (cont'd)

Students should be able to:

- | | | |
|------|---|--|
| 5.3. | use the expressions for the magnetic flux density: | See Appendix II for suggested practical activity. |
| (a) | of a <i>perpendicular</i> distance r from a long straight wire; | $B = \mu_0 I / 2\pi r$ |
| (b) | the centre of a flat circular coil; and, | $B = \mu_0 NI / 2r$ [$N =$ number of turns] |
| (c) | near the centre of an <i>infinitely</i> long solenoid. | $B = \mu_0 nI$ [$n =$ number of turns per unit length = N/L] |

6. Magnetic Forces

Students should be able to:

- | | | |
|------|--|---|
| 6.1. | use Fleming's Left-Hand Rule to predict the direction of the force on a current-carrying conductor in a magnetic field; | |
| 6.2. | use the equation $F = BIL\sin\theta$ to solve problems; | |
| 6.3. | explain how the force on a current-carrying conductor can be used to measure the flux density of a magnetic field by means of a current balance; | See Appendix II for suggested practical activity. |

UNIT 2

MODULE 1: ELECTRICITY AND MAGNETISM (cont'd)

SPECIFIC OBJECTIVES	EXPLANATORY NOTES	SUGGESTED PRACTICAL ACTIVITIES
---------------------	-------------------	--------------------------------

Magnetic Forces (cont'd)

Students should be able to:

- | | | | |
|-------|---|--|---|
| 6.4. | predict the direction of the force on a charge moving in a magnetic field; | Use Fleming's Left-Hand Rule and treat the moving charge as an electric current.

Qualitative discussion of the trapping of charged particles by magnetic fields with specific mention of earth's magnetic field and the Van Allen radiation belt. | |
| 6.5. | use the expression $F = BQv\sin\theta$ to solve problems; | | |
| 6.6. | solve problems involving charged particles moving in mutually perpendicular electric and magnetic fields; | | |
| 6.7. | describe the effect of a soft iron core on the magnetic field due to a solenoid; | Compare this effect with that of the dielectric in a capacitor. | Make a small electro magnet with varying cores and see how many paper clips can be picked up.

<i>See Appendix II for suggested practical activity.</i> |
| 6.8. | explain the principle of the electromagnet; | Uses in door locks, switches and other applications. | |
| 6.9. | explain the origin of the forces between current-carrying conductors; | | |
| 6.10. | predict the direction of the forces; | | |

UNIT 2
MODULE 1: ELECTRICITY AND MAGNETISM (cont'd)

SPECIFIC OBJECTIVES	EXPLANATORY NOTES	SUGGESTED PRACTICAL ACTIVITIES
---------------------	-------------------	--------------------------------

Magnetic Forces (cont'd)

Students should be able to:

- | | | |
|--|---|--|
| 6.11. explain the Hall effect; and, | In developing the explanation, refer to Specific Objective 6.5. | |
| 6.12. use the Hall probe to show variations of flux density. | | |

7. Electromagnetic Induction

Students should be able to:

- | | | |
|---|--|--|
| 7.1. explain magnetic flux; | | |
| 7.2. use the equation $\Phi = BA$ to solve problems; | | |
| 7.3. interpret experiments which demonstrate the relationship between the magnitude and direction of an induced e.m.f. and the change of flux linkage producing the e.m.f.; | | |

Conduct investigations on effects obtained when:

- | | |
|---|--|
| (a) bar magnet moves inside a solenoid; | |
| (b) two flat coils move with respect to each other; | |
| (c) bar magnet moves with respect to flat coil; | |
| (d) one solenoid moves inside another; and, | |
| (e) solenoid moves inside a flat coil. | |

In your explanation, refer to Specific Objective 7.5.

UNIT 2

MODULE 1: ELECTRICITY AND MAGNETISM (cont'd)

SPECIFIC OBJECTIVES	EXPLANATORY NOTES	SUGGESTED PRACTICAL ACTIVITIES
---------------------	-------------------	--------------------------------

Electromagnetic Induction (cont'd)

Students should be able to:

- | | | | |
|------|---|---|---|
| 7.4. | use Faraday's Law of electromagnetic induction to determine the magnitude of an induced e.m.f.; | Include $E = BLv$ for a straight conductor. | See Appendix II for suggested practical activity. |
| 7.5. | use Lenz's Law to determine the direction of an induced e.m.f.; and, | | |
| 7.6. | discuss Lenz's Law as an example of conservation of energy. | | |

Suggested Teaching and Learning Activities

To facilitate students' attainment of the objectives of this Module, teachers are advised to engage students in Practical Activities outlined below.

1. Allow students to conduct research on the origins of the different laws outlined in the Module, for example, Ohm's law, Faraday's laws and Lenz's law.
2. Encourage students to incorporate the use of online resources, such as videos, to visualise concepts.

UNIT 2

MODULE 1: ELECTRICITY AND MAGNETISM (cont'd)

RESOURCES

- | | |
|--------------------------------------|---|
| Adams, S. and Allay, J. | Advanced Physics. Oxford: Oxford University Press, 2000. |
| Breithaupt, J. | Understanding Physics for Advanced Level, 4th Edition. Cheltenham: Nelson Thornes Publishers, 2000. |
| Crundell, M. and Goodwin, G. | Cambridge International AS and A Level Physics. London: Hodder Education, 2014. |
| David, T. | <i>Physics for Cape Unit 2, A CXC® Study Guide. Oxford University Press, 2013.</i> |
| Dobson, K., Grace, D. and Lovett, D. | Physics, 3rd Edition. London: Harper Collins Publishers, 2008. |
| Muncaster, R. | Advanced Level Physics, 4th Edition. London: Nelson Thornes Publishers, 1993. |

Websites

<https://www.penflip.com/shikamikonotz/shika-na-mikono/blob/master/chapter28.txt>

UNIT 2
MODULE 2: AC THEORY AND ELECTRONICS

GENERAL OBJECTIVES

On completion of this Module, students should:

1. understand the principles and operation of the p-n junction diode;
2. understand the characteristics of alternating currents and their applications;
3. understand the use of transducers as input and output devices;
4. understand the use of operational amplifiers in analogue circuits; and,
5. demonstrate proficiency in the use of logic gates in digital circuits.

SPECIFIC OBJECTIVES	EXPLANATORY NOTES	SUGGESTED PRACTICAL ACTIVITIES
----------------------------	--------------------------	---------------------------------------

1. Alternating Currents

Students should be able to:

- | | | |
|--|--|---|
| <p>1.1. use the following terms in relation to an alternating current or voltage:</p> <p>(a) frequency;</p> <p>(b) peak value; and,</p> <p>(c) root-mean-square value;</p> | <p>Recognition that ac voltages and currents are commonly quoted in terms of the RMS values.</p> | |
| <p>1.2. use an equation of the form $x = x_0 \sin \omega t$ to represent an alternating current or voltage;</p> | | |
| <p>1.3. use the relationship that the peak value is $\sqrt{2}$ times the r.m.s. value for the sinusoidal case; and,</p> | <p><i>Recognition that the r.m.s. value of an ac current (or voltage) is equivalent to that value of dc current (or voltage) which would dissipate power at the same rate in a given resistor.</i></p> | <p><i>Perform an experiment to verify the relationship between the peak value of an ac current and the equivalent dc current.</i></p> |

UNIT 2

MODULE 2: AC THEORY AND ELECTRONICS (cont'd)

SPECIFIC OBJECTIVES	EXPLANATORY NOTES	SUGGESTED PRACTICAL ACTIVITIES
---------------------	-------------------	--------------------------------

Alternating Currents (cont'd)

Students should be able to:

- | | | | |
|------|--|---|--|
| 1.4. | discuss the advantages of using alternating current and high voltages for the transmission of electrical energy. | <i>The role of step up and step down transformers in the transmission of electrical power should be mentioned.
The magnitudes of transmission voltages and associated safety concerns should be included.</i> | <i>Record the highest voltages observed on electrical transformers in their neighbourhood.</i> |
|------|--|---|--|

2. The p-n Junction Diode

Students should be able to:

- | | | | |
|------|--|--|--|
| 2.1. | describe the electrical properties of semiconductors; | The population density of holes and electron in intrinsic and doped semiconductors should be mentioned and compared with that for conductors.

Resistivity of semiconductors should be compared to that of conductors in order to place the values in meaningful contexts. | |
| 2.2. | distinguish between p- type and n-type material; | | |
| 2.3. | explain the formation of a depletion layer at a p-n junction; | The fact that a depletion layer forms in the unbiased p-n junction should be emphasised. | |
| 2.4. | discuss the flow of current when the p-n junction diode is forward-biased or reverse-biased; | | |

UNIT 2

MODULE 2: AC THEORY AND ELECTRONICS (cont'd)

SPECIFIC OBJECTIVES	EXPLANATORY NOTES	SUGGESTED PRACTICAL ACTIVITIES
---------------------	-------------------	--------------------------------

The p-n Junction Diode (cont'd)

Students should be able to:

- | | | | |
|-------|--|--|---|
| 2.5. | discuss the IV characteristic of the p-n junction diode; | Mention some applications of diodes and show how these simple characteristics lead to these applications. | Use the diode in a circuit with multimeters and a suitable power source to investigate the IV characteristics. |
| 2.6. | <i>recall that junction transistors consisting of two back-to-back diodes are manufactured as either n-p-n or p-n-p;</i> | <i>Draw diagrams showing the arrangement of the semiconductor types and the labelled circuit symbol for each type of transistor.</i> | <i>Perform experiments to demonstrate qualitatively the operation of the transistor as a switch or amplifier, that is, at cutoff/saturation and the active regions.</i> |
| 2.7. | use the diode for half-wave rectification; | | |
| 2.8. | <i>recall the arrangement of the ac supply, transformer and bridge rectifier diodes in a power supply circuit;</i> | <i>Description of the flow of current through the individual diodes in a bridge rectifier circuit.</i> | |
| 2.9. | represent half-wave and full-wave rectification graphically; and, | | |
| 2.10. | discuss the use of a capacitor for smoothing a rectified ac wave. | Include significance of the time-constant RC. | <i>Set up a simple bridge rectifier circuit with capacitor smoothing, measure and record the shape and magnitude of voltages at important points in the circuit.</i> |

UNIT 2

MODULE 2: AC THEORY AND ELECTRONICS (cont'd)

SPECIFIC OBJECTIVES	EXPLANATORY NOTES	SUGGESTED PRACTICAL ACTIVITIES
---------------------	-------------------	--------------------------------

3. Transducers

Students should be able to:

- | | | | |
|------|---|---|--|
| 3.1. | explain the use of the light-dependent resistor (LDR), the thermistor and the microphone as input devices for electronic circuits; and, | Used if necessary in a potential divider or in a Wheatstone bridge circuit. | Demonstrate using the named devices to show their characteristics. |
| 3.2. | describe the operation of the light-emitting diode (LED), the buzzer and the relay as output devices. | Include use of protective resistor for the LED. | |

4. Operational Amplifiers

Students should be able to:

- | | | | |
|------|--|---|---|
| 4.1. | describe the properties of the ideal operational amplifier; | Infinite input impedance, infinite open loop gain, zero output impedance. | |
| 4.2. | compare the properties of a real operational amplifier with the ideal operational amplifier; | | |
| 4.3. | use the operational amplifier as a comparator; | For example, converting a sine wave to square wave, turning on an alarm when the temperature exceeds a fixed value. | <i>Perform experiment to demonstrate the operation of an op-amp comparator.</i> |
| 4.4. | use the fact that magnitude of the output voltage cannot exceed that of the power supply; | Introduce "clipping" and "saturation". | <i>Demonstrate clipping and saturation using an oscilloscope.</i> |
| 4.5. | explain the meaning of gain and bandwidth of an amplifier; | Typical as well as ideal values for these quantities should be discussed. | |

UNIT 2

MODULE 2: AC THEORY AND ELECTRONICS (cont'd)

SPECIFIC OBJECTIVES	EXPLANATORY NOTES	SUGGESTED PRACTICAL ACTIVITIES
---------------------	-------------------	--------------------------------

Operational Amplifiers (cont'd)

Students should be able to:

- | | | | |
|-------|--|---|---|
| 4.6. | explain the gain-frequency curve for a typical operational amplifier; | Include the fact that gain and frequency are usually plotted on logarithmic axes and explain the reason for this. | |
| 4.7. | determine bandwidth from a gain-frequency curve; | | |
| 4.8. | draw the circuit diagram for both the inverting and non-inverting amplifier with a single input; | Students should be familiar with several representations of the same circuit. | |
| 4.9. | use the concept of virtual earth in the inverting amplifier; | Explanation of why the virtual earth cannot be connected directly to earth although it is “virtually” at earth potential. | |
| 4.10. | use expressions for the gain of both the inverting amplifier and the non-inverting amplifier; | Use the properties of the ideal op-amp. | |
| 4.11. | discuss the effect of negative feedback on the gain and bandwidth of an inverting operational amplifier and non-inverting amplifier; | Mention the effect of negative feedback on other op-amp characteristics. | Use the inverting amplifier to investigate the gain as frequency of the input signal is varied. See Appendix II for suggested practical activity. |
| 4.12. | perform calculations related to single-input amplifier circuits; | Include “cascaded” amplifiers. | |
| 4.13. | use the fact that a non-inverting amplifier has a very high input impedance; | | |

UNIT 2

MODULE 2: AC THEORY AND ELECTRONICS (cont'd)

SPECIFIC OBJECTIVES	EXPLANATORY NOTES	SUGGESTED PRACTICAL ACTIVITIES
---------------------	-------------------	--------------------------------

Operational Amplifiers (cont'd)

Students should be able to:

- | | | |
|---|---|--|
| 4.14. describe the use of the inverting amplifier as a summing amplifier; | Mention of practical uses of summing amplifier, for example, mixing boards. | Use two separate power supplies along with multimeters to investigate the output voltage compared to the input voltages. |
| 4.15. solve problems related to summing amplifier circuits; | Relate to the use of summing amplifier as a digital to analogue convert. | |
| 4.16. describe the use of the operational amplifier as a voltage follower; and, | Mention the important practical use of the voltage follower as a buffer or matching amplifier, for example, effect pedals for guitarists. | |
| 4.17. analyse simple operational amplifier circuits. | Analysis of the response of amplifier circuits to input signals, using timing diagrams. | |

5. Logic Gates

Students should be able to:

- | | | |
|--|--|--|
| 5.1. describe the function of the following logic gates: NOT, AND, NAND, OR, NOR, EXOR, EXNOR; | <i>For logic gate circuit symbols, use the ANSI system.</i>
Include the equivalence relationship between different gates, for example, AND from NOR ^S , OR from NAND ^S , NOR from OR+NOT, NOT from NOR. | |
|--|--|--|

UNIT 2

MODULE 2: AC THEORY AND ELECTRONICS (cont'd)

SPECIFIC OBJECTIVES	EXPLANATORY NOTES	SUGGESTED PRACTICAL ACTIVITIES
---------------------	-------------------	--------------------------------

Logic Gates (cont'd)

Students should be able to:

- | | | |
|-------|---|--|
| 5.2. | use truth tables to represent the function of logic gates with no more than two inputs; | Use of logic tutors (combinations of logic gate chips on one board) to investigate the truth tables of these gates. |
| 5.3. | re-design a logic circuit to contain only NOR gates or only NAND gates; | Circuit should be reduced to minimum chip count. |
| 5.4. | analyse circuits using combinations of logic gates to perform control functions; | |
| 5.5. | construct truth tables for a combination of logic gates; | Students should familiarise themselves at the earliest possible opportunity with the application of logic gates to solve simple real-world problems and a familiar practical example should be described. Logic tutor can be used to investigate these combinations. |
| 5.6. | interpret truth tables for a combination of logic gates; | |
| 5.7. | use timing diagrams to represent the response of digital circuits to different input signals; | |
| 5.8. | draw a circuit to show the construction of a half-adder; | From two NORs and an AND or from EXOR and an AND. Set up circuits to investigate both the half adder and full adder. |
| 5.9. | explain the operations of a half-adder; | |
| 5.10. | use two half-adders and an OR to construct a full-adder; | |

UNIT 2

MODULE 2: AC THEORY AND ELECTRONICS (cont'd)

SPECIFIC OBJECTIVES	EXPLANATORY NOTES	SUGGESTED PRACTICAL ACTIVITIES
---------------------	-------------------	--------------------------------

Logic Gates (cont'd)

Students should be able to:

- | | | |
|-------|---|---|
| 5.11. | explain the operation of a flip-flop consisting of two NAND gates or two NOR gates; | Use of the S-R flip-flop as a latch or memory. |
| 5.12. | describe the operation of the triggered bistable; | |
| 5.13. | combine triggered bistables (T flip-flops) to make a 3-bit binary counter; and, | |
| 5.14. | discuss the application of digital systems in the home and in industry. | Automobile applications can also be used as examples. |

Suggested Teaching and Learning Activities

To facilitate students' attainment of the objectives of this Module, teachers are advised to engage students in teaching and learning activities listed below.

1. Allow students to measure the IV characteristics of different p-n junction diodes.
2. Ask students to construct and test half-wave and full-wave rectification circuits.
3. Have students investigate the smoothing effect of a capacitor on a rectified ac wave.
4. Ask students to measure the response of LDRs, thermistors and microphones to different inputs.
5. Ask students to conduct an investigation on the response of LEDs, buzzers and relays to input signals.
6. Allow students to construct and test comparator circuits using operational amplifiers.

UNIT 2

MODULE 2: AC THEORY AND ELECTRONICS (cont'd)

Suggested Teaching and Learning Activities (cont'd)

7. Ask students to measure the bandwidth of an operational amplifier circuit and determine the effect of negative feedback on bandwidth using an oscilloscope.
8. Encourage students to construct simple amplifier circuits and investigate their response to different signals.
9. Allow students to investigate operational amplifier circuits, which use various input and output transducers.
10. Ask students to design and construct digital circuits using logic gates to perform functions such as alarms and door locks.
11. Engage students in the construction and testing of flip-flop circuits using logic gates to switch devices on and off in a controlled fashion.

RESOURCES

Adams, S. and Allay, J.	<i>Advanced Physics</i> . Oxford: Oxford University Press, 2000.
Breithaupt, J.	<i>Understanding Physics for Advanced Level, 4th Edition</i> . Cheltenham: Nelson Thornes Publishers, 2000.
Crundell, M. and Goodwin, G.	<i>Cambridge International AS and A Level Physics</i> . London: Hodder Education, 2014.
David, T.	<i>Physics for Cape Unit 2, A CXC® Study Guide</i> . Oxford University Press, 2013.
Dobson, K., Grace, D. and Lovett, D.	<i>Physics, 3rd Edition</i> . London: Harper Collins Publishers, 2008.
Muncaster, R.	<i>Advanced Level Physics, 4th Edition</i> . London: Nelson Thornes Publishers, 1993.

UNIT 2

MODULE 3: ATOMIC AND NUCLEAR PHYSICS

GENERAL OBJECTIVES

On completion of this Module, students should:

1. appreciate the photon model for electromagnetic radiation;
2. understand the development of the nuclear model of the atom;
3. appreciate the wave-particle nature of matter and energy;
4. understand the relationship between mass and energy;
5. demonstrate a knowledge of radioactivity and its applications; and,
6. *apply the laws of Physics to solve appropriate problems.*

SPECIFIC OBJECTIVES	EXPLANATORY NOTES	SUGGESTED PRACTICAL ACTIVITIES
---------------------	-------------------	--------------------------------

1. <u>Particulate Nature of Electromagnetic Radiation</u>		
--	--	--

Students should be able to:

- | | | |
|--|---|--|
| 1.1. describe the phenomenon of photoelectric emission; | <i>A description of what happens when uv radiation falls on a zinc plate, or light on materials such as cadmium sulfide and photovoltaic cells.</i> | <i>Measuring current and or change in resistance in devices exposed to light such as photocells.</i> |
| 1.2. use the relationship $E = h f$ to solve problems; | | |
| 1.3. discuss the shortcomings of classical physics to explain aspects of the photoelectric effect; | <i>Mention effect of high and low intensity below and above the cutoff frequency.</i> | |
| 1.4. explain how the photon theory better suits the emission of a photon; | <i>Explanation of the photoelectric effect as evidence for the particulate nature of electromagnetic radiation.</i> | |

UNIT 2

MODULE 3: ATOMIC AND NUCLEAR PHYSICS (cont'd)

SPECIFIC OBJECTIVES	EXPLANATORY NOTES	SUGGESTED PRACTICAL ACTIVITIES
---------------------	-------------------	--------------------------------

Particulate Nature of Electromagnetic Radiation (cont'd)

Students should be able to:

- | | | |
|------|---|---|
| 1.5. | define:
(a) work function (Φ);
(b) threshold frequency (f_0);
(c) cut-off wavelength (λ_0); and,
(d) stopping potential (V_s); | $\Phi = hf_0$ |
| 1.6. | use the relationship
$hf = \Phi + \frac{1}{2}mv^2$
to solve problems; | Or $hf = \Phi + eV_s$

Explanation of why the maximum photoelectric energy is independent of intensity, whereas the photoelectric current is proportional to Intensity. |
| 1.7. | use the electron-volt as a unit of energy; | Students should be familiar with calculations for converting the KE of particles to eV. |
| 1.8. | explain the principles of the production of X-rays by electron bombardment of a metal target; | Include the fact that the emission spectrum has a continuous background component and several line spectra series. Description of the main features of a modern X-ray tube, including control of the intensity. |
| 1.9. | explain the origins of line and continuous X-ray spectra; | <i>Include the absorption or release of energy due to movement of electrons between energy levels.</i>
<i>Include $hf = E_2 - E_1$.</i> |

UNIT 2

MODULE 3: ATOMIC AND NUCLEAR PHYSICS (cont'd)

SPECIFIC OBJECTIVES	EXPLANATORY NOTES	SUGGESTED PRACTICAL ACTIVITIES
---------------------	-------------------	--------------------------------

Particulate Nature of Electromagnetic Radiation (cont'd)

Students should be able to:

- | | | | |
|-------|--|--|---|
| 1.10. | solve problems by using the equation $I = I_0 \exp(-\mu x)$ for the attenuation of X-rays in matter; | μ = linear absorption coefficient. | <i>Measuring attenuation of light through of layers of light filters unto the photocell using a multimeter.</i> |
| 1.11. | discuss the use of X-rays in radiotherapy and imaging in medicine; | Qualitative description of the operation of a CAT scanner should be included here. | |
| 1.12. | discuss how line spectra provide evidence for discrete energy levels in isolated atoms; | | |
| 1.13. | use the relationship $hf = E_2 - E_1$ to solve problems; | An understanding of the existence of discrete electron energy levels in isolated atoms (for example, atomic hydrogen) and deduction of how this leads to spectral lines. | |
| 1.14. | distinguish between absorption and emission line spectra; | <i>Include absence/presence of emission of band of frequencies.</i> | |
| 1.15. | explain the wave-particle nature of matter; | Mention Quantum Physics. | |
| 1.16. | describe the evidence provided by electron diffraction for the wave nature of particles; | | |

UNIT 2

MODULE 3: ATOMIC AND NUCLEAR PHYSICS (cont'd)

SPECIFIC OBJECTIVES	EXPLANATORY NOTES	SUGGESTED PRACTICAL ACTIVITIES
---------------------	-------------------	--------------------------------

Particulate Nature of Electromagnetic Radiation (cont'd)

Students should be able to:

- 1.17. discuss interference and diffraction as evidence of the wave nature of electromagnetic radiation; and,
- 1.18. use the relation for the de Broglie wavelength $\lambda = h/p$ to solve problems.

2. Atomic Structure

Students should be able to:

- | | | |
|---|--|---|
| 2.1. describe the (Geiger-Marsden) α -particle scattering experiment; | Brief account of early theories of atomic structure, including those of Thomson, Bohr and Rutherford, should introduce this section. Interpretation of the results of Geiger Marsden experiment. | |
| 2.2. discuss the evidence the (Geiger-Marsden) α -particle scattering experiment provides for the nuclear model of the atom; | <i>Large relative atomic volume compared to nucleus, positive charge on nucleus, mass of nucleus is approximately mass of atom.</i> | |
| 2.3. describe Millikan's oil drop experiment; and, | Include details of Millikan's experimental design. Mention Stoke's law. | |
| 2.4. discuss the evidence in Millikan's oil drop experiment for the quantisation of charge. | Include interpretation of graphical representation of results. | The experiment includes results for terminal velocity calculations, size of a drop. |

UNIT 2

MODULE 3: ATOMIC AND NUCLEAR PHYSICS (cont'd)

SPECIFIC OBJECTIVES	EXPLANATORY NOTES	SUGGESTED PRACTICAL ACTIVITIES
3. <u>Atomic Mass</u>		
Students should be able to:		
3.1. define 'mass defect' and 'binding energy';	Nuclear Stability should be mentioned. Refer to Specific Objective 4.1.	
3.2. calculate mass defect and binding energy in eV or joules;	Explanation of the relevance of binding energy per nucleon to nuclear fusion and to nuclear fission.	
3.3. use the relationship between energy and mass in nuclear reactions $\Delta E = \Delta m c^2$ to solve problems;	Include calculation of energy release in fission, fusion or nuclear decay. Sketch a labelled diagram to illustrate a chain reaction.	
3.4. use the atomic mass unit (u) as a unit of energy;	Brief account of early theories of atomic structure, including those of Thomson, Bohr and Rutherford, should introduce this section.	
3.5. represent graphically the relationship between binding energy per nucleon and nucleon number;	Mention "Island of stability".	
3.6. compare the values of binding energy per nucleon when undergoing nuclear fission or fusion;	Nuclear fusion is the process by which stars release energy and elements are made, for example, H \rightarrow He.	

UNIT 2

MODULE 3: ATOMIC AND NUCLEAR PHYSICS (cont'd)

SPECIFIC OBJECTIVES	EXPLANATORY NOTES	SUGGESTED PRACTICAL ACTIVITIES
---------------------	-------------------	--------------------------------

Atomic Mass (cont'd)

Students should be able to:

3.7.	<i>illustrate by examples the conservation of nucleon number, proton number, energy and charge in nuclear reactions; and,</i>	<i>Naturally occurring processes such as spontaneous decay of radioactive elements, as well as nuclear fission and nuclear fusion should be referenced.</i>
------	---	---

3.8.	interpret nuclear reactions in the form:	Briefly review isotopes.
------	--	--------------------------

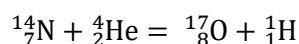
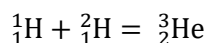

4. Radioactivity

Students should be able to:

4.1.	relate radioactivity to nuclear instability;	Refer to Specific Objective 3.1.
------	--	----------------------------------

4.2.	discuss the spontaneous and random nature of nuclear decay;	Refer to the random nature of radioactive decay from the fluctuations in count rate. Sketch the exponential nature of radioactive decay.	See Appendix II for suggested practical activity.
------	---	---	---

4.3.	identify the origins and environmental hazards of background radiation;	The deleterious effects of high energy radiation on living tissue should be highlighted.
------	---	--

4.4.	describe experiments to distinguish between the three types of emissions from radioactive substances;	
------	---	--

UNIT 2

MODULE 3: ATOMIC AND NUCLEAR PHYSICS (cont'd)

SPECIFIC OBJECTIVES	EXPLANATORY NOTES	SUGGESTED PRACTICAL ACTIVITIES
<u>Radioactivity (cont'd)</u>		
Students should be able to:		
4.5. write equations for radioactive decay;		
4.6. interpret equations for radioactive decay;		
4.7. discuss the environmental hazards of radioactive emissions;	Special attention should be paid to potential nuclear biohazards in the Caribbean environment.	
4.8. discuss the necessary safety precautions for handling and disposal of radioactive material;	<i>Including the use of personal protective equipment (PPE), double hull ships and thick concrete as part of handling and disposal.</i>	
4.9. explain: (a) activity; (b) decay constant; and, (c) half- life;	$A = \lambda N$	See Appendix II for suggested practical activity.
4.10. use the law of decay $\frac{dN}{dt} = -\lambda N$ and $N = N_0 \exp(-\lambda t)$ to solve problems;		See Appendix II for suggested practical activity.
4.11. use the relation $T_{\frac{1}{2}} = \frac{\ln 2}{\lambda}$ to solve problems;	<i>Apply this equation to any similar process such as half thickness.</i>	
4.12. describe an experiment to determine the half-life of a radioactive isotope with a short half-life;	<i>Half life of Radon-220.</i>	<i>Simulations of the half life/half thickness using absorption of light through filters of varying thickness.</i>

UNIT 2

MODULE 3: ATOMIC AND NUCLEAR PHYSICS (cont'd)

SPECIFIC OBJECTIVES	EXPLANATORY NOTES	SUGGESTED PRACTICAL ACTIVITIES
---------------------	-------------------	--------------------------------

Radioactivity (cont'd)

Students should be able to:

- | | | |
|-------|--|---|
| 4.13. | discuss uses of radioisotopes as tracers for carbon dating and in radiotherapy; and, | The characteristics of an isotope which make it suitable for use in radiotherapy should be highlighted. |
| 4.14. | describe the operation of simple detectors. | (For example, G-M tube, spark counter, cloud chamber, ratemeter and scaler). <i>Include explanation of jet trail in upper atmosphere.</i> |

Suggested Teaching and Learning Activities

To facilitate students' attainment of the objectives of this Module, teachers are advised to engage students in teaching and learning activities listed below.

1. Allow students to examine the line spectra of different substances to deduce information about energy levels.
2. Ask students to measure the absorption effect of different materials of different thickness (on the three types of radioactive emissions).
3. Allow students to test whether the water loss from a burette or a leaky soft drink bottle is exponential.
4. Have students perform a radioactive decay simulation using dice or coins.
5. *Have students simulate radioactive decay and absorption using photocell and filters.*

UNIT 2

MODULE 3: ATOMIC AND NUCLEAR PHYSICS (cont'd)

RESOURCES

Adams, S. and Allay, J.	Advanced Physics. Oxford: Oxford University Press, 2000.
Breithaupt, J.	Understanding Physics for Advanced Level, 4th Edition. Cheltenham: Nelson Thornes Publishers, 2000.
Crundell, M. and Goodwin, G.	Cambridge International AS and A Level Physics. London: Hodder Education, 2014.
David, T.	<i>Physics for Cape Unit 2, A CXC® Study Guide. Oxford University Press, 2013.</i>
Dobson, K.; Grace, D. and Lovett, D.	Physics, 3rd Edition. London: Harper Collins Publishers, 2008.
Muncaster, R.	Advanced Level Physics, 4th Edition. London: Nelson Thornes Publishers, 1993.

Websites

<https://www.youtube.com/watch?v=NvhL0I3evwI>

<http://www.wikiradiography.net/page/Characteristics+and+Production+of+X-rays>

<https://www.youtube.com/watch?v=uHu9aa0QDiE>

<https://www.youtube.com/watch?v=wilNTUZoAiw>

<https://www.youtube.com/watch?v=1uPyq63aRvg>

<https://www.youtube.com/watch?v=zDQH5x7svfg>

<https://www.youtube.com/watch?v=IXs61QYyU5o>

<https://www.youtube.com/watch?v=dNp-vP17asl>

◆ OUTLINE OF ASSESSMENT

EXTERNAL ASSESSMENT (80%)

Paper 01 (1 hour 30 minutes)	Forty-five multiple-choice items, 15 from each Module.	40%
Paper 02 (2 hours 30 minutes)	Three compulsory structured essay questions, one from each Module. Each question is worth 30 marks.	40%
Paper 032 For private candidates only (2 hours)	Three questions, one from each Module, as follows: (a) a practical-based question to be executed by the candidate; (b) a question based on data analysis; and (c) a data analysis/a planning and design exercise.	20%

SCHOOL-BASED ASSESSMENT (20%)

The School-Based Assessment will consist of selected practical laboratory exercises and one research project aligned to any Unit of the **CAPE®** Sciences (Biology, Chemistry or Physics).

MODERATION OF SCHOOL-BASED ASSESSMENT

The reliability (consistency) of the marks awarded by teachers on the School-Based Assessment is an important characteristic of high quality assessment. To assist in this process, the Council undertakes on-site moderation of the School-Based Assessment during Term 2/3. This is conducted by visiting External Moderators who will visit the centre.

Teachers are required to present to the Moderator **ALL** Assessment Sheets (Record of Marks), **ALL** lab books, Mark Schemes and the project or evidence of the project. This is also required when marks are being transferred from one Unit/subject to another. Candidates marks are to be recorded on the School-Based Assessment Record Sheets which are available online via the **CXC®**'s website www.cxc.org. **All candidates' marks are to be submitted electronically** using the SBA data capture module of the Online Registration System (ORS). **Teachers are NOT required to submit to CXC® samples of candidates' work, unless specifically requested to do so by the Council.**

The Moderator will re-mark the skills and projects for a sample of five candidates using the guidelines below. This is **only** applicable if the candidates selected in the sample are not using transferred marks for the projects.

1. Candidates' total marks on the SBA are arranged in descending order (highest to lowest).

2. The sample comprises the work of the candidates scoring the:
 - (a) highest Total Mark;
 - (b) middle Total Mark;
 - (c) lowest Total Mark;
 - (d) mark midway between the highest and middle Total Mark; and,
 - (e) mark midway between the middle and lowest Total Mark.
3. *The Moderator will also re-mark the laboratory practical activities for the other skills (ORR, AI and PD) that are recorded in the lab books for the five candidates in the sample.*
4. *The Moderator will re-mark the skills for **ALL** the candidates where the total number of candidates is five or less than five.*
5. *The Moderator will provide teachers with feedback. Please note that Candidates' marks may be adjusted as a result of the moderation exercise.*

*The Moderators are required to submit the moderated marks (Moderation of SBA Sample Form), the Moderation Feedback Report and the External Moderator Report to the Local Registrar by **30 June** of the year of the examination.*

*A copy of the Assessment Sheets and all candidates' work must be retained by the school for **three months** after the examination results are published by **CXC**[®].*

ASSESSMENT DETAILS

Each Unit of the syllabus is assessed as outlined below.

External Assessment by Written Papers (80% of Total Assessment)

1. Paper 01 consists of 45 multiple-choice items. There will be a combined question paper and answer booklet for Paper 02.
2. S.I. Units will be used on all examination papers.
3. The use of silent, non-programmable calculators will be allowed in the examination. Candidates are responsible for providing their own calculators.
4. Data not specifically required to be recalled, defined or stated will be made available for this examination.

Paper 01 (1 hour 30 minutes – 40% of Total Assessment)

1. Composition of the Paper

This paper will consist of 45 multiple-choice items, 15 from each Module. All questions are compulsory and knowledge of the entire Unit is expected. The paper will assess the candidate's knowledge across the breadth of the Unit.

2. Mark Allocation

The paper will be worth 45 marks, which will be weighted to 90 marks.

3. Question Type

Questions may be presented using diagrams, data, graphs, prose or other stimulus material.

Paper 02 (2 hours 30 minutes – 40% of Total Assessment)

1. Composition of Paper

This paper will consist of three questions, one from each module. *All questions are compulsory.*

Questions on this paper test all three skills KC, UK and XS.

Knowledge of the entire Unit is expected.

2. Mark Allocation

The paper will be worth 90 marks, 30 marks per question *and distributed across the question sub-parts.*

3. Question Type

Questions will be presented in *structured essay format*. *The questions will test the skills of KC, UK and XS.* Answers are to be written in the question booklet.

School-Based Assessment (20%)

School-Based Assessment is an integral part of student assessment in the course covered by this syllabus. It is intended to assist students in acquiring certain knowledge, skills and attitudes that are associated with the subject. *Students are encouraged to work in groups.*

During the course of study for the subject, students obtain marks for the competence they develop and demonstrate in undertaking their School-Based Assessment assignments. These marks contribute to the final marks and grades that are awarded to students for their performance in the examination.

School-Based Assessment provides an opportunity to individualise a part of the curriculum to meet the needs of students. It facilitates feedback to the student at various stages of the experience. This helps to build the self-confidence of students as they proceed with their studies. School-Based Assessment also facilitates the development of the critical skills and abilities emphasised by this **CAPE®** subject and enhances the validity of the examination on which candidate performance is reported.

School-Based Assessment, therefore, makes a significant and unique contribution to both the development of relevant skills and the testing and rewarding of students for the development of those skills.

The Caribbean Examinations Council seeks to ensure that the School-Based Assessment scores that contribute to the overall scores of candidates are valid and reliable estimates of accomplishment. The guidelines provided in this syllabus are intended to assist in doing so.

Award of Marks

The following skills will be assessed through the laboratory practical activities:

1. Analysis and Interpretation;
2. Manipulation and Measurement;
3. Observation, Recording and Reporting; and,
4. Planning and Designing.

The candidates are also required to do an investigative project in any one Unit of the CAPE® Sciences. The table below shows how the marks are allocated for each Unit.

Table 1
School-Based Assessment Skills

Skill	Unit 1	Unit 2
Observation, Recording and Reporting	12	12
Manipulation and Measurement	12	12
Analysis and Interpretation*	12	12
Planning and Designing*	12	12
TOTAL	48 marks	48 marks

***Includes an investigative project**

Teachers are required to provide criteria which clearly indicate how they award marks.

Please note that candidates will be required to do one investigative project in any Unit of any of the CAPE® Sciences (Biology, Chemistry or Physics) *in the first sitting, and can* use that mark for the other Units of the Sciences. So for example, a candidate may do the investigative project in Unit 2 Physics *in the first sitting*, and then (transfer) use the AI and PD marks for Unit 1 Physics, Units 1 and 2 Chemistry and Units 1 and 2 Biology.

Each Module will carry a maximum of 16 marks.

Each candidate's total School-Based Assessment mark for any Unit should be divided in three and allocated to each Module equally.

Fractional marks should not be awarded. Wherever the Unit mark is not divisible by three, then

- (a) when the remainder mark is 1, it should be allocated to Module 1; and,
- (b) when the remainder is 2, one of the marks should be allocated to Module 2 and the other mark to Module 3.

Appropriate practical exercises for assessing any skill may be selected from any Module in the relevant Unit.

◆ INVESTIGATIVE PROJECT

Objectives of the Investigative Project

The Investigative Project must focus on a challenge to be addressed within the environment or society. On completion of the Investigative Project students should:

1. Appreciate the use of the scientific method for discovery of new knowledge and to the solution of problems;
2. Communicate accurately and effectively the purpose and results of research;
3. Apply experimental skills and theory to the solution of problems; and,
4. Synthesise information based on data collected.

Students are encouraged to work collaboratively. Where collaborative work is done, group sizes must not exceed six (6) persons per group. The teacher is expected to use the group mark for the project and add it to the marks for the other skills for each individual candidate within the group.

CRITERIA FOR ASSESSING INVESTIGATIVE SKILLS

A.	PLANNING AND DESIGN		
	• HYPOTHESIS		1
	• AIM		1
	• MATERIALS AND APPARATUS		1
	• VARIABLES STATED		3
	- Controlled	1	
	- Manipulated	1	
	- Responding	1	

<ul style="list-style-type: none"> • METHOD <ul style="list-style-type: none"> - Clearly outlining how manipulated variable will be changed and measured. - Clearly outlining how the responding variable will be measured. 	1	2	
	1		
	1	2	
<ul style="list-style-type: none"> • RESULTS <ul style="list-style-type: none"> - Expected Results - Treatment of Results 	1		
1			
2	2		
<ul style="list-style-type: none"> • PRECAUTIONS AND LIMITATIONS/ASSUMPTIONS <ul style="list-style-type: none"> - Two or more stated - Anyone stated 	2		
1			
TOTAL			

B.	ANALYSIS AND INTERPRETATION		
<ul style="list-style-type: none"> • RESULTS <ul style="list-style-type: none"> - Complete set of results from quantities mentioned in method. • DISCUSSION <ul style="list-style-type: none"> - Complete set of calculations or statement of observations or trends. - Interpretations of calculated values, observations or trends linked to data in results. • LIMITATIONS AND SOURCES OF ERROR <ul style="list-style-type: none"> - Limitation stated - Source of error stated • REFLECTIONS <ul style="list-style-type: none"> - Relevance of experiment to real life. - Impact of knowledge gained from experiment. - How can experiment be changed and improved. • CONCLUSION <ul style="list-style-type: none"> - Clearly stated and related to Aim in PD. 	2	2	
	2	4	
	2		
	1	2	
	1		
	1	3	
1	1	1	
TOTAL			(12)

SCHOOL-BASED ASSESSMENT – GENERAL GUIDELINES FOR TEACHERS

1. Each candidate is required to keep a laboratory workbook which is to be marked by the teacher. Teachers are also expected to assess candidates as they perform practical exercises in which Manipulation and Measurement skills are required.
2. A maximum of two skills may be assessed by any one experiment.

3. The mark *awarded* for each skill assessed by practical exercises should be the average of at LEAST TWO separate assessments. *The average mark for AI and PD must include the mark from the investigative project.* In each Unit, total marks awarded at the end of each Module will be 0 to 16.
4. The maximum mark for any skill will be 12. The mark *awarded* for each skill assessed by practical exercises should be the average of at LEAST TWO separate assessments. In each Unit, total marks awarded at the end of each Module will be 0 to 16.
5. Candidates who do not fulfil the requirements for the School-Based Assessment will be considered absent from the whole examination.

Candidates' laboratory books should contain all practical work undertaken during the course of study. Those exercises which are selected for use for the School-Based Assessment should be clearly identified. The skill(s) tested in these selected practical exercises, the marks assigned and the scale used must be placed next to the relevant exercises.

◆ REGULATIONS FOR PRIVATE CANDIDATES

1. Candidates who are registered privately will be required to sit Papers 01, 02 and 032. Detailed information on Papers 01, 02 and 032 is given on page 70 of this syllabus.
2. Paper 032 will constitute 20 per cent of the overall assessment of the candidates' performance on the Unit.

◆ REGULATIONS FOR RESIT CANDIDATES

1. *Candidates may reuse any moderated SBA score within a two-year period. In order to assist candidates in making decisions about whether or not to reuse a moderated SBA score, the Council will continue to indicate on the preliminary results if a candidate's moderated SBA score is less than 50 per cent in a particular Unit.*
2. *Candidates reusing SBA scores should register as "Re-sit candidates" and must provide the previous candidate number when registering.*
3. *Resit candidates must complete Papers 01 and 02 of the examination for the year in which they register.*

◆ ASSESSMENT GRID

The Assessment Grid for each Unit contains marks assigned to papers and to Modules and percentage contribution of each paper to total scores.

<i>Paper</i>	<i>Module 1</i>	<i>Module 2</i>	<i>Module 3</i>	<i>Paper Total (Weighted Total)</i>	<i>% Weighting of Papers</i>
<i>Paper 01</i>	15 (30)	15 (30)	15 (30)	45 (90)	40
<i>Paper 02</i>	30	30	30	90	40
<i>Paper 031</i>	16 (15)	16 (15)	16 (15)	48 (45)	20
<i>Paper 032</i>	15	15	15	45	20
<i>Module Totals</i>	60	60	60	180 (225)	100
<i>Weighted Module</i>	75	75	75	225	100

◆ GLOSSARY OF EXAMINATION TERMS

KEY TO ABBREVIATIONS

KC – Knowledge and Comprehension

UK – Use of Knowledge

XS – Experimental Skills

WORD	DEFINITION	NOTES
Analyse	examine in details.	(UK)
Annotate	requires a brief note to be added to a label.	(KC)
Apply	requires the use of knowledge or principles to solve problems and to explain or predict behaviours in other situations.	(UK)
Assess	requires the inclusion of reasons for the importance of particular structures, relationships or processes.	(UK)
Calculate	requires a numerical answer for which working must be shown.	(UK)
Cite	requires a quotation or a reference to the subject.	(KC)
Classify	requires a division into groups according to observable and stated characteristics.	(UK)
Comment	requires the statement of an opinion or a view, with supporting reasons.	(UK)
Compare	requires a statement about similarities and differences.	(UK)

WORD	DEFINITION	NOTES
Construct	requires either the use of a specific format for the representations, such as graphs, using data or material provided or drawn from practical investigations, or the building of models or the drawing of scale diagrams.	(UK)
Deduce	implies the making of logical connections between pieces of information.	(UK)
Define	requires a formal statement or an equivalent paraphrase, such as the defining equation with symbols identified.	(KC)
Demonstrate	show; requires an algebraic deduction to prove a given equation.	(KC/UK)
Derive	implies a deduction, determination, or extraction of some relationship, formula or result from data by a logical set of steps.	(UK)
Describe	requires a statement in words (using diagrams where appropriate) of the main points of the topic. This can also imply the inclusion of reference to (visual) observations associated with particular phenomena or experiments. The amount of description intended should be interpreted from the context.	(KC)
Design	includes planning and presentation with appropriate practical detail.	(UK/XS)
Determine	implies that the quantity concerned should not be measured directly but should be obtained by calculation or derivation.	(UK)

WORD	DEFINITION	NOTES
Develop	implies an expansion or elaboration of an idea or argument, with supporting evidence.	(UK)
Differentiate or Distinguish	requires a statement and brief explanation of the differences between or among items which can be used to define the items or place them into separate categories.	(KC/UK)
Discuss	requires a critical account of the points involved in the topic.	(UK)
Draw	requires a line representation of the item, showing accurate relationships between the parts.	(KC/UK)
Estimate	implies a reasoned order of magnitude, statement or calculation of the quantity concerned, using such simplifying assumptions as may be necessary about points of principle and about the values of quantities not otherwise included.	(UK)
Evaluate	requires the weighing of evidence and judgements based on stated criteria.	(UK)
Explain	implies that a definition or a description should be given, together with some relevant comment on the significance or context of the term or situation concerned. The amount of supplementary comment intended should be interpreted from the context.	(KC/UK)
Find	requires the location of a feature or the determination as from a graph.	(KC/UK)

WORD	DEFINITION	NOTES
Formulate	implies the articulation of a hypothesis.	(UK)
Identify	requires the naming of specific components or features.	(KC)
Illustrate	implies a clear demonstration, using appropriate examples or diagrams.	(KC)
Interpret	explain the meaning of.	(UK)
Investigate	requires the careful and accurate gathering and analysis of data concerning a given topic (numerical or otherwise).	(UK/XS)
Label	implies the inclusion of names to identify structures or parts as indicated by pointers.	(KC)
List	requires a number of points with no elaboration. Where a given number of points is specified, this should not be exceeded.	(KC)
Measure	implies that the quantity concerned can be directly obtained from a suitable measuring instrument.	(UK/XS)
Name	requires only the identification of the item.	(KC)
Note	implies recording observations.	(KC/XS)
Observe	implies the direction of attention to details which characterise reaction or change taking place and examination and scientific notations.	(UK/XS)

WORD	DEFINITION	NOTES
Plan	implies preparation to conduct an exercise or operation.	(XS)
Predict	implies the use of information to arrive at a likely conclusion or the suggestion of possible outcomes.	(UK)
Record	implies an accurate account or description of the full range of observations made during given procedure.	(XS)
Relate	implies the demonstration of connections between sets of facts or data.	(UK)
Show	See Demonstrate.	
Sketch	in relation to graphs, implies that the shape or position of the curve need only be qualitatively correct and depending on the context, some quantitative aspects may need to be included. In relation to diagrams, implies that a simple, freehand drawing is acceptable, provided proportions and important details are made clear.	(KC/UK/XS)
State	implies a concise statement with little or no supporting argument.	(KC)
Suggest	could imply either that there is no unique response or the need to apply general knowledge to a novel situation.	(UK)
Test	implies the determination of a result by following set procedures.	(UK/XS)
Use	implies the need to recall and apply knowledge or principles in order to solve problems and to explain or predict behaviours.	(UK)

◆ PRACTICAL ACTIVITIES

The teacher is urged to reinforce the relevant approved codes and safety practices during the delivery of all practical activities in the Module.

ARCHIMEDES' PRINCIPLE

Refer to Unit 1, Module 1, Specific Objective 4.1 and 4.4

Aim: To determine the upthrust on an object totally immersed in water.

The balance you will use, illustrated in Fig. 1, consists of a metre rule suspended by a thread from a retort stand and clamp.

Method: First, adjust the position of the thread on the rule so that it balances horizontally on its own with no other masses suspended. Record the position of the thread.

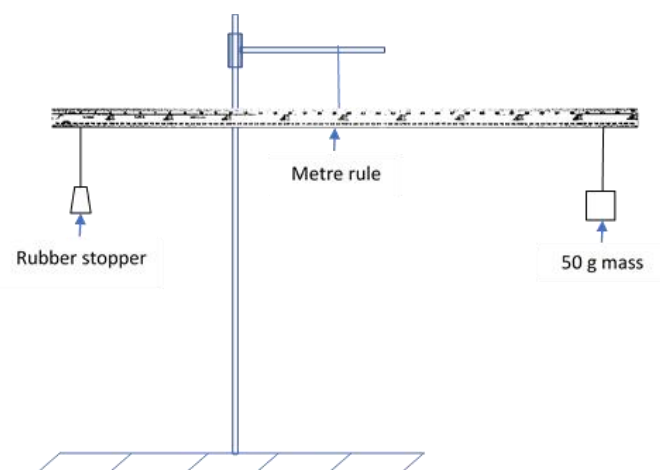

Take the RUBBER stopper provided and suspend it by a thread close to one end of the metre rule. Now balance the rule by suspending a 100g mass by a thread on the other side of the rule. The rule should be horizontal when balanced. Record the point of suspension of the 100g mass.

When the rule is balanced, the principle of moments states that the sum of the moments of forces about the point of suspension in the clockwise direction is equal to the sum of the moments in the anticlockwise direction.

Draw a diagram indicating forces acting on the rule. Write an equation for the balance of the moments of the forces. Hence, determine the mass of the stopper.

Q.1 Why balance the metre rule with nothing suspended at the start?

Leaving the stopper suspended from the same point, place a beaker of water below the stopper and arrange it so that the stopper is completely immersed in water. Now find a new position for suspension of the 100 g mass so that the rule is again balanced. Be careful to see that the stopper does not touch the edge or bottom of the beaker. All the results should be carefully tabulated.

PRACTICAL ACTIVITIES (cont'd)

From the above readings calculate the “apparent weight” of the stopper while it was immersed in water. The loss of weight is due to the upthrust of the water or “buoyancy force”. Archimedes Principle shows that: upthrust = weight in air – apparent weight in water (assuming air gives negligible upthrust). Thus, find the upthrust on the stopper.

Q.2 Does it matter how far below the surface of the water you immerse the stopper, providing you do not touch the bottom? Why?

A. Determination of upthrust on an object floating in water

Place the CORK stopper provided in a beaker of water. Note that since the cork is floating it is only partially immersed.

Q.3 What must the relation be between the upthrust on the stopper and its weight? What is this upthrust in your case? You may use the commercial balance to determine the mass of the cork.

B. Determination of the weight of water displaced by the rubber and cork stoppers

For these measurements a displacement measuring vessel (d.m.v.) is used. Place the d.m.v. on the shelf over the sink. Fill it with water until water runs out of the spout into the sink. Wait a minute or so until the water has stopped draining from the spout then place an empty beaker under the spout and carefully lower the rubber stopper into the displacement measuring vessel (d.m.v). Find the weight of the displaced water collected in the beaker. Again, wait until the water has completely stopped draining from the spout. Repeat the above procedure with the cork and find the weight of water displaced by the floating cork in the beaker.

Compare the weights of displaced water with the upthrust found in the corresponding cases in A and B above.

PRACTICAL ACTIVITIES (cont'd)

THE DISTRIBUTION OF ERRORS IN PHYSICAL MEASUREMENTS

Refer to Unit 1, Module 1, Specific Objective 1.8

Aim: To examine how errors are distributed in measurements of a physical quantity.

Method: The experiment is divided into three sections.

A. The Normal Distribution

Attach a plain sheet of paper to the soft board mounted on the wall. Make a suitable mark or marks on the paper at the level of the middle of the paper. Stand at a distance from the board and throw darts at the level on the paper where you estimate your eye level to be. According to your throwing ability several trial throws may be necessary before the most suitable throwing distance is found.

Make a total of 100 throws. More than one sheet of paper may be used (if necessary) as long as the same reference marks are used to position each. Be careful, however, otherwise your graph will be poor.

Divide the vertical range of the points on the paper(s) into 10 equal sections of the suitable width, say, for example, 2 cm. (See Figure 1). Count the number of points in each section and tabulate the results. A few points may be below section 1 or above section 10 but they should NOT be discarded. Label these sections 0, 1,..... (Note: Use a big enough sheet of paper so that your throws land on paper).

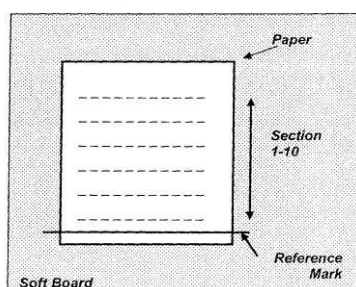

Fig. 1

Draw a histogram illustrating the number of times, n_i , that points occur in a certain section, x_i (Figure 2). Note the following about the histogram:

- Each number 0, 1,.....10, on the x_i axis, is at the centre of a section, for example, 9 is at the centre of section 9.
- The histogram must show a section with n_i at both the start and end.
- Connect the mid-points by a smooth curve as shown. This need not go through all the midpoints.

PRACTICAL ACTIVITIES (cont'd)

Random errors should cause the histogram to approximately follow a bell-shaped curve called the **Normal Distribution**.

Now calculate the mean value of the measurements, \bar{x} , using the formula:

$\bar{x} = \frac{1}{N} \sum n_i x_i$ where N =total number of points and x_i can have 1 – 10. Mark the mean value \bar{x} on the histogram.

Finally, note on your paper where the mean value x_i is located and reposition your paper on the soft board. Use the meter rule provided to obtain the height of the mean value x_i above the floor. Example: Suppose $x = 5.2$ locate the height of section 5.2 above the ground level. (It would be about 150 – 22 cm). Note that 5.0 refers to the midpoints of section 5 and 0.2 is 0.2 x the distance between the midpoints of sections 5 and 6.

Also measure directly the height of your eyes above the floor.

Comment on your results.



Fig. 2

B. Standard Deviation

The degree to which numerical data are scattered about an average value is called the dispersion of the data. Common measures of the dispersion are the mean deviation and the standard deviation may be used.

If data are grouped such that x_1, x_2, \dots occur with frequencies n_i x_i the following form of standard deviation may be use.

$$\sqrt{\frac{\sum n_i (x_i - \bar{x})^2}{N}}$$

Small values of standard deviation indicate that there is not much dispersion or scatter of the data.

(i) For the data obtained in part (A) of the experiment calculate the standard deviation.

PRACTICAL ACTIVITIES (cont'd)

- (ii) Your experimental value for your eye level is, therefore, $\bar{x} \pm s$. Express this in term of heights. (Remember you have already found \bar{x} from (A). Example: Suppose $s = 1.4$. If each section in your experimental sheet was 1.5 cm wide, then $s = 1.4$ implies $1.4 \times 1.5 = 2.1$ cm.

Your experimental value for your eye level is \bar{x} in cm \pm s in cm.

- C. Repeat the experiment by standing at a longer distance ($\frac{1}{2}$ to 2 times your previous throwing distance) away from the board. You may have to use more sheets firmly fastened together so that all your throws land on the sheets. You may also have to divide your sheets into more sections of approximately 2 cm to cover all your points.

Plot a histogram of the new results and calculate $\bar{x} \pm s$ in cm again.

Comment on your results.

STATIONARY WAVES

Refer to Unit 1, Module 2, Specific Objective 2.9

- Aims: (a) To investigate the properties of stationary waves.
(b) To measure the wavelength and frequency of microwaves.
(c) To estimate the velocity of sound in free air.

Method:

- A. Stationary waves on a string

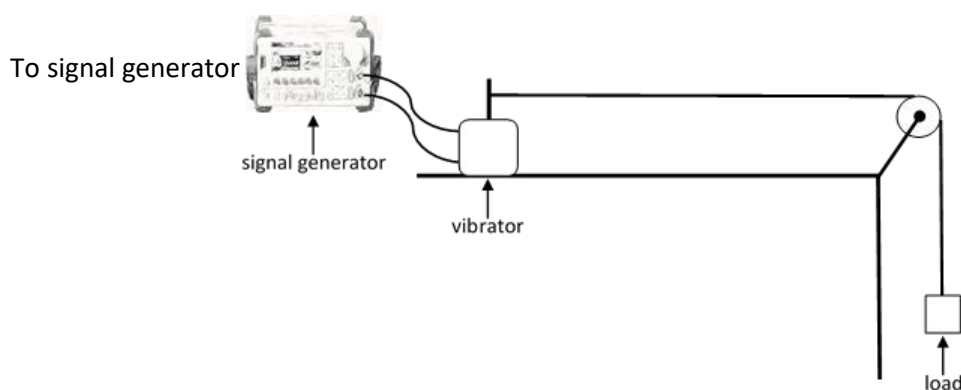

Turn on the signal generator and find the frequency required to produce a one-loop standing wave. Then find other frequencies which give 2 loops, 3 loops

By means of a linear graph use your results to find the velocity of the waves on the string.

PRACTICAL ACTIVITIES (cont'd)

B. Stationary Microwaves

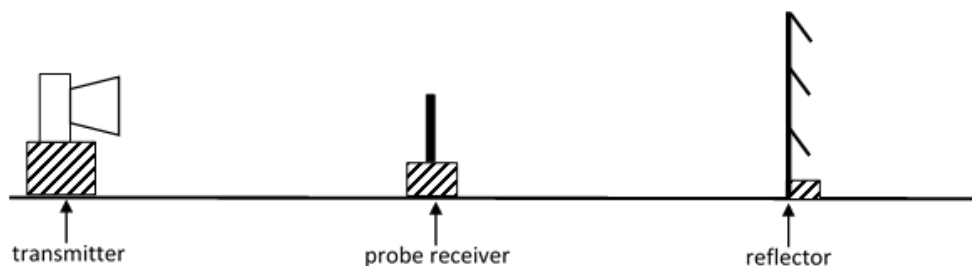

By moving the probe receiver find a number of consecutive nodes and hence measure the wave length. Explain why this is better than trying to find the distance between two nodes. Use $c=f\lambda$ to find the frequency of the microwaves ($c = 3.00 \times 10^8 \text{ ms}^{-1}$)

C. Stationary Sound Waves

(Note that this set-up will only yield an approximate value for the wavelength)

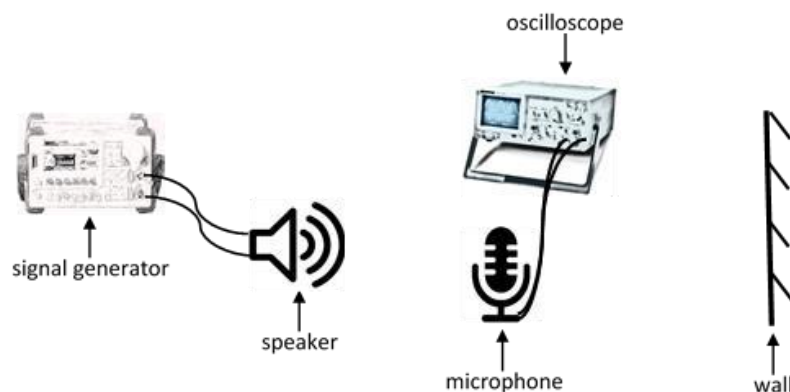

Find the distance between two consecutive nodes and, hence, find the wavelength of the sound. Find v from $v=f\lambda$. Repeat the experiment for a different frequency.

REFRACTION AND THE CRITICAL ANGLE

Refer to Unit 1, Module 2, Specific Objective 2.23 and 2.25

Aim: To investigate the refraction of light at an air/Perspex boundary and use the data obtained to find the critical angle for light traveling from Perspex to air.

Method: Use pins to trace the passage of light through a semi-circular block of perspex for various angles of incidence. Note that the light is incident on the flat face and you must look at the alignment of the pins through the curved surface. [If available a light box could be used to trace the rays instead of pins]

PRACTICAL ACTIVITIES (cont'd)

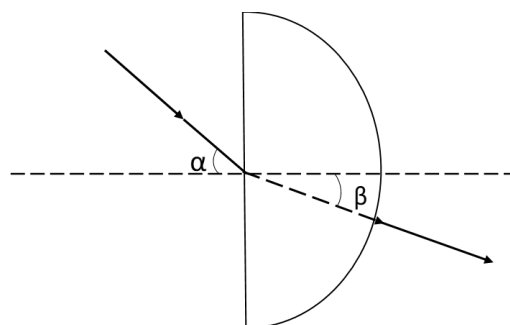

It is important that you take care in setting up the apparatus: if the incident ray does not go through the centre of the circle then the refracted ray will bend again at the curved surface.

Plot a graph of β against α and extend the graph to find the value of β when α is 90° .

Also plot a linear graph with the same data and obtain a second value for the critical angle.

In your summary comment on the relative merits of the two alternative ways of handling the data.

LATENT HEAT

Refer to Unit 1, Module 3, Specific Objective 2.7

Aim: To determine:

- (i) the specific latent heat of vaporisation of a liquid by an electrical method: and
- (ii) the specific latent heat of fusion of ice by the method of mixtures.

Method: (a) The more sophisticated apparatus in the text may not be available, in which case the apparatus shown below can be used. The principle is the same. The energy supplied after the liquid has started to boil is equal to the heat required to boil off a mass n of liquid plus the heat to the surroundings, H , that is, $VIt = mL + H$.

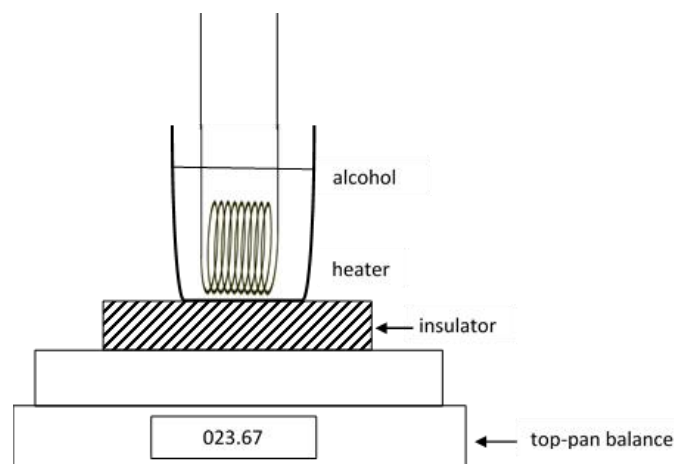

If the procedure is repeated with different values of V and I but with the same time, t , then the last term may be eliminated by subtraction. (Explain why the heat loss is the same in both cases, provided the time is the same).

PRACTICAL ACTIVITIES (cont'd)

- (b) A Styrofoam cup, which has a negligible heat capacity, is to be used as the calorimeter.

Carefully consider the possible errors in this method before starting. A good way of reducing the effect of the surroundings is to start the experiment with the water in the cup above room temperature and add small pieces of dried ice until the temperature is same amount below room temperature.

STRETCHING GLASS AND RUBBER

Refer to Unit 1, Module 3, Specific Object 6.12

- Aims:** (a) To compare the breaking stress of glass with that of rubber.
(b) To investigate the behaviour of rubber when it is loaded and unloaded.

Method: **Stretching glass could be dangerous so this part of the experiment will be performed by the laboratory assistant. Warning: BE VERY CAREFUL with the glass. Do not have your eyes near it at any time.**

You will be provided with a piece of rubber band. Add loads to it until it breaks and make other necessary measurements so that you can work out the breaking stress.

Using a similar piece of rubber to that in (a) add masses in 100 g increments until the load is 300 g less than the maximum. For each load measure the extension of the rubber. Continue measuring the extension as the load is removed. Plot a graph to illustrate your results.

- Note:** It is best not to measure the length of the rubber between the support and the knot because the rubber might slip. Instead use two fine ink marks drawn on the band.

(Preparation: Glass rod is heated and a hook made. Then it is heated in the centre and stretched to produce a thin section.)

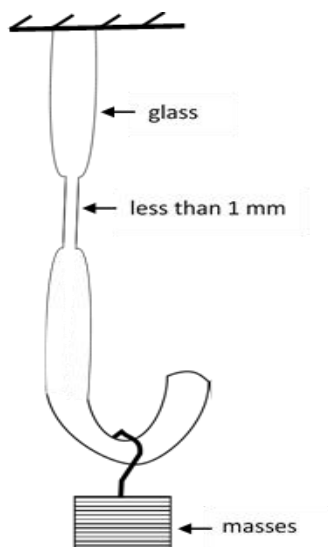

PRACTICAL ACTIVITIES (cont'd)

THE MAGNETIC FIELD OF A SOLENOID

Refer to Unit 2, Module 1, Specific Objective 5.3

Aim: To investigate the factors affecting the magnetic flux density of a solenoid.

This experiment uses a Hall probe and a direct current flowing in the solenoid. The reading on the voltmeter connected to the probe is directly proportional to B . Sometimes, the meter is already calibrated in mT but usually a conversion factor is used.

Method: (a) Two of the solenoids provided have the same area and length but a different number of turns (which is marked on them). Ensuring that the currents are the same in each by connecting them in series, investigate how B at the centre of the solenoid depends on n , the turn concentration, for at least three different current values.

Also move the probe from side to side to see how the field varies across the solenoid.

(b) Choose a pair of solenoids with the same number of turns per unit length, n , but different areas and investigate how B depends on the area of cross-section when the other factors are kept constant. Repeat with different currents.

(c) Investigate how the field at the centre of a solenoid depends on the current flowing in it.

Find B at various positions along the solenoid axis and plot a graph to display your results.

FORCE ON CURRENT-CARRYING CONDUCTOR

Refer to Unit 2, Module 1, Specific Objective 6.3

Aim: To test the relationship $F=BIL$ for the force on a current-carrying conductor.

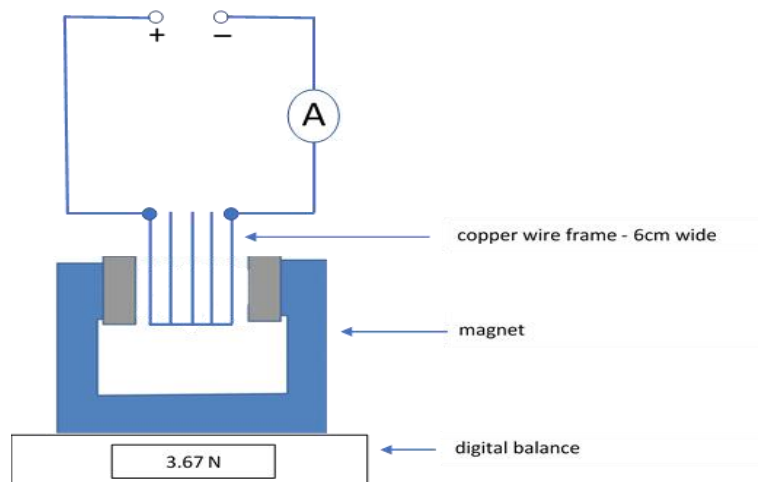

PRACTICAL ACTIVITIES (cont'd)

Method: Set up the apparatus shown above so that an upward force will be exerted on the wire when the current is flowing. Before switching on, press the tare bar on the balance to set the reading at zero.

Since the conductor is forced upward, an equal and opposite force will push the magnet down (Newton III) so the force on the wire may be calculated from the balance reading.

According to the texts, the force on a current-carrying wire AT RIGHT ANGLES to a uniform field is:

- (a) proportional to the current, I , flowing in the conductor; and,
- (b) proportional to the length, L , of the conductor.

Use this apparatus to test these two statements.

Also use both sets of data to find the proportionally constant B (known as the flux density of the uniform field) in the relationship, $F=BIL$.

THE LAWS OF ELECTROMAGNETIC INDUCTION

Refer to Unit 2, Module 1, Specific Objective 7.4

Aim: To test the Faraday relationship: induced e.m.f. equals the rate of change of magnetic flux linkage.

$$E = N A \frac{dB}{dt}$$

Theory

Flux linkage = NAB where N is the number of turns in the secondary coil, A is the area of the coil and B is the magnetic flux density produced by the primary coil.

To investigate the relationship above, two of the quantities must remain constant while the third is varied. (Note that the rate of change of B depends on the rate of change of I which is proportional to the frequency).

Apparatus: Pair of solenoids of square cross-section; one has twice the area of the other.

Signal generator: use the low impedance output and set the frequency on the 100 to 1000 Hz range.

Cathode ray oscilloscope for measuring the peak induced voltage.

A.C. ammeter to ensure that the current is constant (so that B is constant).

Long length of insulated copper wire to wind various numbers of turns on the solenoids.

PRACTICAL ACTIVITIES (cont'd)

THE GAIN OF AN INVERTING AMPLIFIER

Refer to Unit 2, Module 2, Specific Objective 4.11

Aim: To plot the transfer characteristic of an op. amp. connected as an inverting amplifier and measure its gain.

Method: Set up the circuit shown. Use one of the potential dividers provided on the op. amp. Board to control the input and digital voltmeters to monitor the input and the output p.d.'s.

Use the data collected to plot the transfer characteristic (V_o against V_i).

Find the gain of the amplifier from a second graph of the linear region only and compare the value with the theoretical value.

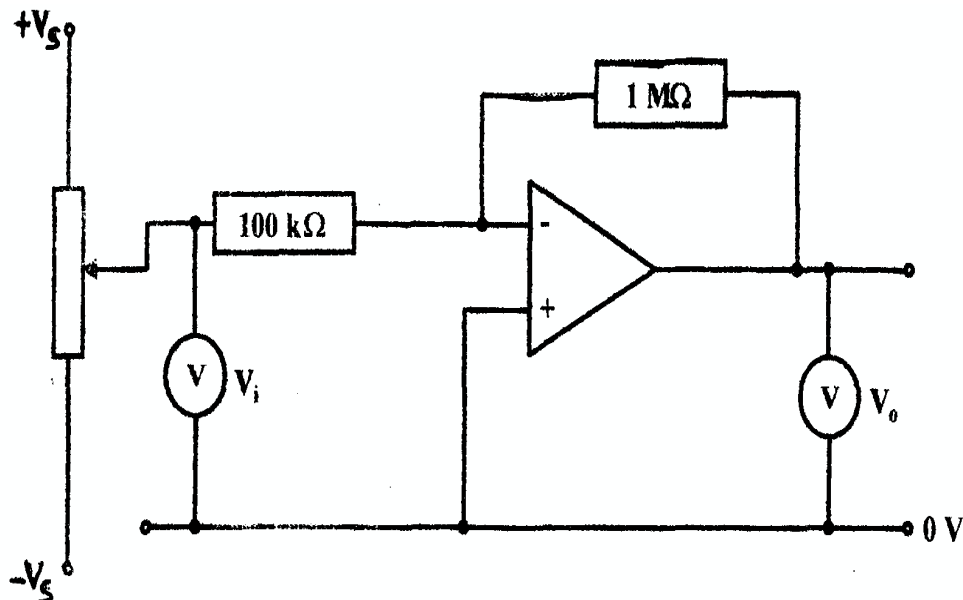

THE FREQUENCY RESPONSE OF A NON-INVERTING AMPLIFIER

Refer to Unit 2, Module 2, Specific Objective 4.11

Aim: To investigate how the gain of an amplifier changes when the frequency is increased.

Method: Using one of the blue op. amp. circuit boards, set up a non-inverting amplifier with a feedback resistance of $1000\text{ k}\Omega$ and input resistance of $10\text{ k}\Omega$. Theoretically the gain should be 101 but, given the tolerance of the resistors, it can be taken as 100 for the purposes of this investigation.

Use an audio-frequency signal generator to provide a sinusoidal input and monitor both the input signal and the output using a double beam oscilloscope.

PRACTICAL ACTIVITIES (cont'd)

Note:

1. Make sure that both the gain controls of the c.r.o. are set on calibrate before taking measurements.
2. A quick way to check that the gain of the non-inverting amplifier is 100 is to set the gain (volts per division) for the output trace on a value 100 times bigger than that for the input trace. If the gain is 100 the two traces will then be the same size.
3. If the output is saturated the input signal may be reduced using the volume control and/or the attenuator control.

Repeat the investigation using a gain of about 1000 and plot log graphs to display the results of your investigation.

RADIOACTIVITY

Refer to Unit 2, Module 3, Specific Objective 4.2

- Aims:**
- (a) To show that radioactive decay is a random process.
 - (b) To investigate the decay of thoron (radon-220) gas.

- Method:**
- (a) Radium-226 has a half-life of 1620 years and so its activity cannot change appreciably during the course of an experiment.

Set the scaler-timer on "rate" and "continuous". Bring the radium source close to the G-M tube and leave it fixed in this position. Obtain a series of readings for the count-rate and plot them on a histogram to show their distribution about the mean value.

- (b) Thoron gas is an isotope of radon ${}_{86}^{220}\text{Rn}$ produced in the radioactive series that starts with a long half-life isotope of thorium ${}_{90}^{232}\text{Th}$. All the other

nuclides in the series have half-lives either much longer or much shorter than thoron gas so they do not contribute to the activity of the sample of the gas. The thorium is in powdered form in a sealed plastic bottle and the thoron gas is produced in the air space above the powder.

Set the scaler timer to "count". Find the background count-rate by switching on the counter for 100s. This value is used to correct the count-rates in the thoron decay.

Using two-tubes with one-way valves, the radon gas can be transferred into a bottle containing the end of a Geiger- Muller tube by squeezing the thorium bottle a few times. The whole system is sealed and should be quite safe but to make sure, keep all the windows open and **if any leak occurs, evacuate the room, and report to your teacher or the laboratory technician immediately.**

PRACTICAL ACTIVITIES (cont'd)

When the gas is transferred, switch on the counter and start timing. Record the count every 20 seconds for about 5 minutes. From these readings the number of decays in each 20s interval can be found and hence the count-rate at 10s, 30s, 50s.

Plot a graph to show how the activity varies with time and use the graph to obtain a value for the half-life of the radon.

The activity of the thoron (radon-220) will decay exponentially so you should be able to derive an equation suitable for plotting a linear graph from which the half-life may also be found. By selecting the part of the graph before the decay gets too random a more precise value than the first one may be obtained.

RADIOACTIVE DECAY SIMULATION

Refer to Unit 2, Module 3, Specific Objective 4.9

Aim: To verify some of the principles of radioactivity using dice as simulated atoms.

Method: Throw the entire set of 500 cubes into the large tray provided and remove every cube with a six facing up. It may be necessary to carefully move some of the cubes so that they are not stacked on top each other. Place the remaining cubes into the original container and repeat the entire process until less than 10 cubes are left. Plot the total number left for each trial against the throw number. You should remember that the curve should be smooth. It does not need to go through every point.

Also, use the data to plot a linear graph. From each graph determine the half-life of your cubes in terms of throws and, from this, find the decay constant.

How does the decay constant compare with the probability of an individual cube “decaying”?

HALF-LIFE OF A CAPACITOR DISCHARGE

Refer to Unit 2, Module 3, Specific Objective 4.10

Aim: To use the concept of half-life to accurately measure a large capacitance.

Theory:

During discharge, the p.d. across a capacitor varies exponentially:

$$V = V_0 \exp(-t / RC)$$

Use this equation to derive the relationship between RC and the half-life of the discharge (that is, the time it takes for the p.d. to fall $\frac{1}{2} V_0$).

PRACTICAL ACTIVITIES (cont'd)

Method: You will be provided with a set of 1% tolerance resistors and a high impedance (digital) voltmeter. Design a suitable circuit and have the supervisor check it before switching on.

Use the circuit to find the average time it takes for the p.d. to reduce to half its initial value. Vary the value of R to obtain sufficient data to plot a suitable linear graph. Use the graph to determine the given capacitance.

THE MAGNETIC FIELD LINES AROUND CURRENT CARRYING SOLENOID.

Refer to Unit 2 Module 1 Specific Objective 6.7

Objective:

To observe the magnetic field lines around current carrying solenoid.

Theory:

1. A coil of many circular turns of insulated copper wire wrapped closely in the shape of a cylinder is called a solenoid.
2. The pattern of the magnetic field lines around a current-carrying solenoid is illustrated in Fig.1.
3. The pattern of the field is similar to magnetic field around a bar magnet. One end of the solenoid behaves as a magnetic north pole, while the other behaves as the south pole.
4. The field lines inside the solenoid are in the form of parallel straight lines. This indicates that the magnetic field is the same at all points inside the solenoid. That is, the field is uniform inside the solenoid.

Apparatus:

A cardboard, a circular coil, a battery, a switch and iron filings.

Procedure:

1. Take a cardboard with two holes in it.
2. Pass a circular coil having large number of turns through these holes such that half the coil is above it and the remaining part is below the cardboard.
3. Connect the free ends of the coil to a battery, and a switch in series.
4. Sprinkle iron filings on the cardboard and on the switch.
5. Tap the cardboard few times and observe the pattern of iron filings that is formed on cardboard.

Observations:

1. You will observe that the field lines inside the solenoid are in the form of parallel straight lines.
2. When the current is reduced to 0, magnetic field intensity around the solenoid reduces to 0.
3. When we increase the amplitude of 'current' or the 'coil turn density', the magnetic field intensity around the solenoid increases.
4. When we reverse the direction of current the polarity of the solenoid is also reversed.

cdac.olabs.edu.in,. (2012). The magnetic field lines around current carrying solenoid.. Retrieved 30 May 2017, from cdac.olabs.edu.in/?sub=74&brch=9&sim=91&cnt=6

◆ LIST OF MINIMUM LABORATORY REQUIREMENTS

(Recommended quantity per 15 candidates)

QTY ITEM

Mechanics

7	Balances - Spring balance (0 – 10N)
7	Balances - Top-pan
15	Stop watches
7	Micrometers
15	Meter rules
7	Vernier calipers
7	Trolleys
7	Springs
7	Strings
7	Pulleys
7	Pendulums
7	Masses

Oscillation and Waves

7	Diffraction grating
7	Waves sources
7	Turning forks
7	Resonance tubes
15	Ray boxes
7	Slinkies
1	Ripple tanks
15	Pendulum bobs
7	Lenses
7	Glass blocks
15	Prisms

QTY ITEM

A C Theory and Electronics

7	Logic gates (NAND, NOR, NOT, AND and OR)
7	Breadboards
24	Connecting wires
7	Logic tutors
7	Semiconductor diodes
7	Operational amplifiers
7	Resistors
7	Rheostats
7	Thermistors
7	Multimeters
7	Centre-zero galvanometers
7	Voltmeters
7	Ammeters
9	AC-DC power supplies
2	Soldering irons
7	Microphones
15	Speakers
7	Battery holders
20	Flashlight bulbs
7	Dual power supplies

Atomic and Nuclear Physics

7	α , β and γ (lab) sources
7	GM tubes
7	Geiger counters
7	Ratemeters
	Scalers
7	Lead (Pb)
7	Aluminium (Al) foil
7	LDRs
15	LEDs
7	Buzzers
7	Relays

LIST OF MINIMUM LABORATORY REQUIREMENTS (cont'd)

Thermal and Mechanical Properties of Matter

15	Heating coils
7	Bunsen burners
7	Immersion heaters
3	Heating plates
	Thermometers
7	Calorimeters
3	Serle's apparatus
3	Lee's discs

Electricity and Magnetism

7	Copper rods
7	Copper wires
7	Nylon wires
7	Constantan wires
7	Other resistance wires
10	Plastic wrap or cling film
7	Glass rods
7	Polythene rods
7	Material strips - fur or cotton
7	Magnets
7	Plotting compasses
7	Hall probes
7	Signal generators
3	CRO
10	Capacitors

◆ LIST OF PHYSICAL CONSTANTS

Universal gravitational constant	G	=	$6.67 \times 10^{-11} \text{ N m}^2 \text{ kg}^{-2}$
Acceleration due to gravity	g	=	9.80 m s^{-2}
Radius of the Earth	R_E	=	6380 km
Mass of the Earth	M_E	=	$5.98 \times 10^{24} \text{ kg}$
Mass of the Moon	M_m	=	$7.35 \times 10^{22} \text{ kg}$
Atmosphere	Atm	=	$1.00 \times 10^5 \text{ N m}^{-2}$
Boltzmann's constant	k	=	$1.38 \times 10^{-23} \text{ J K}^{-1}$
Coulomb constant		=	$9.00 \times 10^9 \text{ N m}^2 \text{ C}^{-2}$
Mass of the electron	m^e	=	$9.11 \times 10^{-31} \text{ kg}$
Electron charge	e	=	$1.60 \times 10^{-19} \text{ C}$
Density of water		=	$1.00 \times 10^3 \text{ kg m}^{-3}$
Resistivity of steel		=	$1.98 \times 10^{-7} \Omega \text{ m}$
Resistivity of copper		=	$1.80 \times 10^{-8} \Omega \text{ m}$
Thermal conductivity of copper		=	$400 \text{ W m}^{-1} \text{ K}^{-1}$
Specific heat capacity of aluminium		=	$910 \text{ J kg}^{-1} \text{ K}^{-1}$
Specific heat capacity of copper		=	$387 \text{ J kg}^{-1} \text{ K}^{-1}$
Specific heat capacity of water		=	$4200 \text{ J kg}^{-1} \text{ K}^{-1}$
Specific latent heat of fusion of ice		=	$3.34 \times 10^5 \text{ J kg}^{-1}$
Specific latent heat of vaporisation of water		=	$2.26 \times 10^6 \text{ J kg}^{-1}$
Avogadro number	N_A	=	$6.02 \times 10^{23} \text{ per mole}$
Speed of light in free space	c	=	$3.00 \times 10^8 \text{ m s}^{-1}$
Permeability of free space	μ_0	=	$4\pi \times 10^{-7} \text{ H m}^{-1}$

LIST OF PHYSICAL CONSTANTS (cont'd)

Permittivity of free space	ϵ_0	=	$8.85 \times 10^{-12} \text{ F m}^{-1}$
The Planck constant	h	=	$6.63 \times 10^{-34} \text{ J s}$
Unified atomic mass constant	u	=	$1.66 \times 10^{-27} \text{ kg}$
Rest mass of proton	m_p	=	$1.67 \times 10^{-27} \text{ kg}$
Molar gas constant	R	=	$8.31 \text{ J K}^{-1} \text{ mol}^{-1}$
Stefan- Boltzmann constant	σ	=	$5.67 \times 10^{-8} \text{ W m}^{-2} \text{ K}^{-4}$
Mass of neutron	m_n	=	$1.67 \times 10^{-27} \text{ kg}$

◆ MATHEMATICAL REQUIREMENTS

Arithmetic

Students should be able to:

1. recognise and use expressions in decimal and standard form (scientific notation);
2. recognise and use binary notations;
3. use appropriate calculating aids (electronic calculator or tables) for addition, subtraction, multiplication and division. Find arithmetic means, powers (including reciprocals and square roots), sines, cosines, tangents (and the inverse functions), natural and base-10 (ln and lg);
4. take account of accuracy in numerical work and handle calculations so that significant figures are neither lost unnecessarily nor carried beyond what is justified; and,
5. make approximations to check the magnitude of machine calculations.

Algebra

Students should be able to:

1. change the subject of an equation. Most relevant equations involve only the simpler operations but may include positive and negative indices and square roots;
2. solve simple algebraic equations. Most relevant equations are linear but some may involve inverse and inverse square relationships. Linear simultaneous equations and the use of the formula to obtain the solution of quadratic equations are included;
3. substitute physical quantities into physical equations, using consistent units and check the dimensional consistency of such equations;
4. formulate simple algebraic equations as mathematical models of physical situations, and identify inadequacies of such models;
5. recognise and use the logarithmic forms of expressions like ab , a/b , x^n , e^{kx} , and understand the use of logarithms in relation to quantities with values that range over several orders of magnitude;
6. express small changes or errors as percentage and vice versa; and,
7. comprehend and use the symbols $<$, $>$, \approx , $/$, \propto , $\langle x \rangle$ or \bar{x} , Σ , Δx , δx , v .

MATHEMATICAL REQUIREMENTS (cont'd)

Geometry and Trigonometry

Students should be able to:

1. calculate areas of right-angled and isosceles triangles, circumferences and areas of circles and areas and volumes of rectangular blocks, cylinders and spheres;
2. use Pythagoras' theorem, similarity of triangles, and the sum of the angles of a triangle;
3. use sines, cosines and tangents (especially for 0° , 30° , 45° , 60° , 90°). Use the trigonometric relationship for triangles:
$$\frac{a}{\sin A} = \frac{b}{\sin B} = \frac{c}{\sin C}; \quad a^2 = b^2 + c^2 - 2bc \cos A;$$
4. use $\sin \theta \approx \tan \theta \approx \theta$ and $\cos \theta \approx 1$ for small θ and $\sin^2 \theta + \cos^2 \theta = 1$; and,
5. understand the relationship between degrees and radians (defined as arc/radius), translate from one to the other and use the appropriate system in context.

Vectors

Students should be able to:

1. find the resultant of two coplanar vectors, recognising situations where vector addition is appropriate; and,
2. obtain expressions for components of a vector in perpendicular directions and using this to add or subtract vectors.

Graphs

Students should be able to:

1. translate information between graphical, numerical, algebraic and verbal forms;
2. select appropriate variables and scales for graph plotting;
3. determine the slope, intercept and intersection for linear graphs;
4. choose by inspection, a line which will serve as the best line through a set of data points presented graphically;
5. recall standard linear form $y = mx + c$ and rearrange relationships into linear form where appropriate;
6. sketch and recognise the forms of plots of common simple expressions like $1/x$, x^2 , a/x^2 , $\sin x$, $\cos x$, e^{-x} , $\sin^2 x$, $\cos^2 x$;

MATHEMATICAL REQUIREMENTS (cont'd)

7. use logarithmic plots to test exponential and power law variations;
8. understand, draw and use the slope of a tangent to a curve as a means to obtain the gradient, and use notation in the form dy/dx for a rate of change; and,
9. understand and use the area below a curve, where the area has physical significance.

◆ SUMMARY OF KEY QUANTITIES, SYMBOLS AND UNITS

The following list illustrates the symbols and units which will be used in question papers.

Quantity	Usual Symbols	Usual Unit
<u>Base Quantities</u>		
mass	M	kg
length	L	m
time	T	s
electric current	I	A
Luminous intensity	I _v	Cd
thermodynamic temperature	T	K
amount of substance	N	mol
<u>Other Quantities</u>		
distance	D	m
displacement	s, x	m
area	A	m ²
volume	V, v	m ³
density	ρ	kg m ⁻³
speed	u, v, w, c	m s ⁻¹
velocity	u, v, w, c	m s ⁻¹
acceleration	a	m s ⁻²
acceleration of free fall	g	m s ⁻²
force	F	N
weight	W	N
momentum	p	N s

SUMMARY OF KEY QUANTITIES, SYMBOLS AND UNITS (cont'd)

Quantity	Usual Symbols	Usual Unit
<u>Other Quantities (cont'd)</u>		
work	w, W	J
energy	E, U, W	J
potential energy	E_p	J
kinetic energy	E_k	J
heat energy	Q	J
change of internal energy	ΔU	J
power	P	W
pressure	p	Pa
torque	τ	N m
gravitational constant	G	$\text{N kg}^{-2} \text{ m}^2$
gravitational field strength	g	N kg^{-1}
gravitational potential	ϕ	J kg^{-1}
angle	θ	$^\circ, \text{rad}$
angular displacement	θ	$^\circ, \text{rad}$
angular speed	ω	rad s^{-1}
angular velocity	ω	rad s^{-1}
period	T	s
frequency	f	Hz
angular frequency	ω	rad s^{-1}
wavelength	λ	m
speed of electromagnetic waves	c	m s^{-1}

SUMMARY OF KEY QUANTITIES, SYMBOLS AND UNITS (cont'd)

Quantity	Usual Symbols	Usual Unit
<u>Other Quantities (cont'd)</u>		
electric charge	Q	C
elementary charge	e	C
electric potential	V	V
electric potential difference	V	V
electromotive force	E	V
resistance	R	Ω
resistivity	ρ	$\Omega \text{ m}$
electric field strength	E	$\text{N C}^{-1}, \text{V m}^{-1}$
permittivity of free space	ϵ_0	F m^{-1}
capacitance	C	F
time constant	τ	s
magnetic flux	Φ	Wb
magnetic flux density	B	T
permeability of free space	μ_0	H m^{-1}
stress	σ	Pa
strain	ϵ	
force constant	k	N m^{-1}
Young modulus	E	Pa
Celsius temperature	θ	$^{\circ}\text{C}$
molar gas constant	R	$\text{J K}^{-1} \text{ mol}^{-1}$
Boltzmann constant	k	J K^{-1}

SUMMARY OF KEY QUANTITIES, SYMBOLS AND UNITS (cont'd)

Quantity	Usual Symbols	Usual Unit
<u>Other Quantities (cont'd)</u>		
Avogadro constant	N_A	mol^{-1}
number density (number per unit volume)	N	m^{-3}
Planck constant	h	J s
work function energy	Φ	J
activity of radioactive source	A	Bq
decay constant	λ	s^{-1}
half-life	$t_{1/2}$	s
relative atomic mass	A_r	
relative molecular mass	M_r	
atomic mass	m_a	kg, u
electron mass	m_e	kg, u
neutron mass	m_n	kg, u
proton mass	m_p	kg, u
molar mass	M	kg
proton number	Z	
nucleon number	A	
neutron number	N	
Stefan-Boltzmann constant	σ	$\text{W m}^{-2} \text{K}^{-4}$

◆ RESOURCES

Supplementary Texts

- Christman, R. J. *A Student's Companion: Halliday, Resnick and Walker. Fundamentals of Physics (including extended chapter).* New York: John Wiley and Sons, Inc., 1997.
- Duncan, T. *Advanced Physics.* London: Hodder Murray, 2000.
- Duncan, T. *Electronics for Today and Tomorrow.* London: Hodder Murray, 1997.
- Floyd, T. *Digital Fundamentals.* London: (Prentice Hall) Pearson, 2005.
- Giancoli, D. C. *Physics: Principles with Applications.* London: Prentice Hall, 2004.
- Halliday, D., Resnic, R., and Walker, J. *Fundamentals of Physics, 8th Edition.* New York: John Wiley and Sons, Inc., 2007.
- Hallsworth, K.D. *Electronic Boxes.* Barbados: Akada Media.
- Nelkon, M. and Parker, P. *Advanced Level Physics.* London: Heinemann, 1994.
- Reviere, R. et al. *Preliminary Physics Study Guide.* Cave Hill, Barbados: The University of West Indies, 1997.

Western Zone Office
9 August 2018

CARIBBEAN EXAMINATIONS COUNCIL

Caribbean Advanced Proficiency Examination® CAPE®



PHYSICS

Specimen Papers and Mark Schemes/Keys

Specimen Papers:

Unit 1 Paper 01
Unit 1 Paper 02
Unit 2 Paper 01
Unit 2 Paper 02
Unit 2 Paper 32

Mark Schemes and Key:

Unit 1 Paper 01
Unit 1 Paper 02
Unit 2 Paper 01
Unit 2 Paper 02
Unit 2 Paper 32

CARIBBEAN EXAMINATIONS COUNCIL

CARIBBEAN ADVANCED PROFICIENCY EXAMINATION

PHYSICS

SPECIMEN 2017

TABLE OF SPECIFICATIONS

Unit 1 – Paper 02

Module	Question	Specific Objective	Content	Cognitive Level Marks			Total
				KC	UK	XS	
1	1	3.17,3.19, 3.20, 4.3, 4.5,	Effects of Forces Motions -Newton’s Laws, Circular motion	10	15	5	30
2	2	1.4, 1.7, 2.23, 2.26,	Harmonic Motion Properties of Waves	10	15	5	30
3	3	4.1, 4.2, 4.3, 4.5, 5.5, 5.6,	Kinetic Theory of Gases First Law of Thermodynamics	10	15	5	30
Total				30	45	15	90

Unit 1 – Paper 032 (Alternative to SBA)

Module	Question	Specific Objective	Content	Cognitive Level Marks			Total
				KC	UK	XS	
1	1	Practical	Module 2	0	5	10	15
2	2	Data Analysis	Module 3	0	5	10	15
3	3	Planning & Design	Module 2	0	5	10	15
Total				0	15	30	45

Unit 2 – Paper 02

Module	Question	Specific Objective	Content	Cognitive Level Marks			Total
				KC	UK	XS	
1	1	1.9, 1.10, 1.11, 4.6, 4.7, 4.8, 4.9,	Electrical Quantities Capacitors	10	15	5	30
2	2	4.10, 4.11, 4.14, 5.1, 5.2, 5.4, 5.6, 5.9, 5.10	Operational Amplifiers Logic gates	10	15	5	15
3	3	1.15, 1.18, 3.2, 3.3, 4.5, 4.9, 4.10, 4.11, 4.12	Atomic and Nuclear Physics Atomic Mass Radioactivity	10	15	5	30
Total				30	45	15	90

Unit 2 – Paper 032 Alternative to SBA

Module	Question	Specific Objective	Content	Cognitive Level Marks			Total
				KC	UK	XS	
1	1	Practical	Module 2	0	5	10	15
2	2	Data Analysis	Module 1	0	5	10	15
3	3	Planning & Design	Module 3	0	5	10	15
Total				0	15	30	45



CANDIDATE – PLEASE NOTE!

PRINT your name on the line below and return this booklet with the answer sheet. Failure to do so may result in disqualification.

TEST CODE **02138010**

SPEC 2017/02138010

**CARIBBEAN EXAMINATIONS COUNCIL
CARIBBEAN ADVANCED PROFICIENCY EXAMINATION®**

PHYSICS

Unit 1 - Paper 01

1 hour 30 minutes

SPECIMEN PAPER

READ THE FOLLOWING INSTRUCTIONS CAREFULLY.

1. This test consists of 45 items. You will have 1 hour and 30 minutes to answer them.
2. In addition to this test booklet, you should have an answer sheet.
3. Do not be concerned that the answer sheet provides spaces for more answers than there are items in this test.
4. Each item in this test has four suggested answers lettered (A), (B), (C), (D). Read each item you are about to answer and decide which choice is best.
5. On your answer sheet, find the number which corresponds to your item and shade the space having the same letter as the answer you have chosen. Look at the sample item below.

Sample Item

Which of the following lists has one scalar quantity and one vector quantity?

Sample Answer

- (A) Mass:temperature
- (B) Momentum:pressure
- (C) Force:velocity
- (D) Potential energy:volt



The correct answer to this item is “Momentum:pressure”, so (B) has been shaded.

6. If you want to change your answer, erase it completely before you fill in your new choice.
7. When you are told to begin, turn the page and work as quickly and as carefully as you can. If you cannot answer an item, go on to the next one. You may return to that item later.
8. You may do any rough work in this booklet.
9. Figures are not necessarily drawn to scale.
10. You may use a silent, non-programmable calculator to answer items.

DO NOT TURN THIS PAGE UNTIL YOU ARE TOLD TO DO SO.

Copyright © 2017 Caribbean Examinations Council
All rights reserved.

LIST OF PHYSICAL CONSTANTS

Universal gravitational constant	G	=	$6.67 \times 10^{-11} \text{ N m}^2 \text{ kg}^{-2}$
Acceleration due to gravity	g	=	9.81 m s^{-2}
1 Atmosphere	atm	=	$1.00 \times 10^5 \text{ N m}^{-2}$
Boltzmann's constant	k	=	$1.38 \times 10^{-23} \text{ J K}^{-1}$
Density of water	ρ_w	=	$1.00 \times 10^3 \text{ kg m}^{-3}$
Specific heat capacity of water	C_{water}	=	$4200 \text{ J kg}^{-1} \text{ K}^{-1}$
Specific latent heat of vaporization of water	L_V	=	$2.26 \times 10^6 \text{ J kg}^{-1}$
Avogadro's number	N_A	=	6.02×10^{23} per mole
Molar gas constant	R	=	$8.31 \text{ J K}^{-1} \text{ mol}^{-1}$
Stefan–Boltzmann's constant	σ	=	$5.67 \times 10^{-8} \text{ W m}^{-2} \text{ K}^{-4}$
Speed of light in free space (vacuum)	c	=	$3.0 \times 10^8 \text{ m s}^{-1}$
Triple point temperature	T_{tr}	=	273.16 K
1 tonne	t	=	1000 kg

GO ON TO THE NEXT PAGE

1. Which of the following pairs of units are SI base units?

- (A) ampere, newton
- (B) kelvin, ampere
- (C) watt, coulomb
- (D) coulomb, kelvin

Item 2 refers to the following two vectors, P and Q.



2. Which of the vector triangles shows the correct resultant $R = Q + P$?

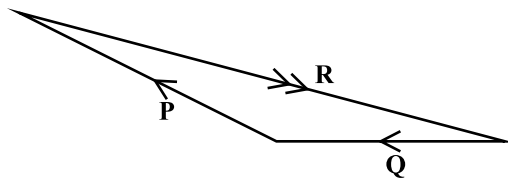

(A)

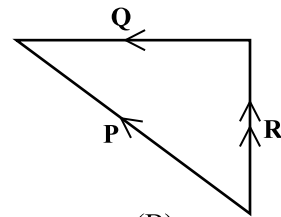

(B)

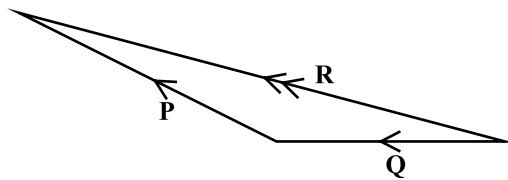

(C)

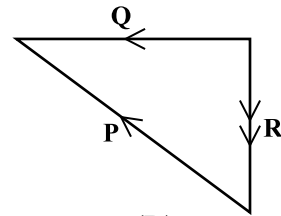

(D)

Item 3 refers to the following figure showing how the displacement of a particle varies with time.

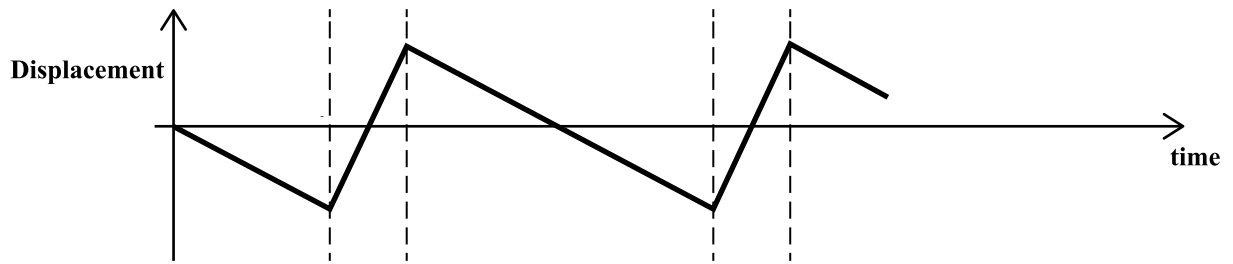

3. Which of the following graphs correctly represents the dependence of velocity with time for this motion?

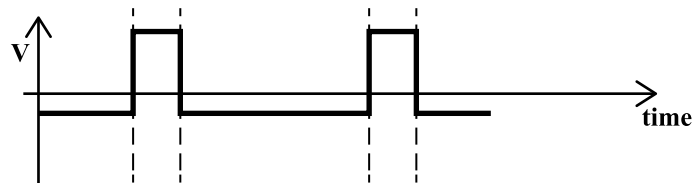
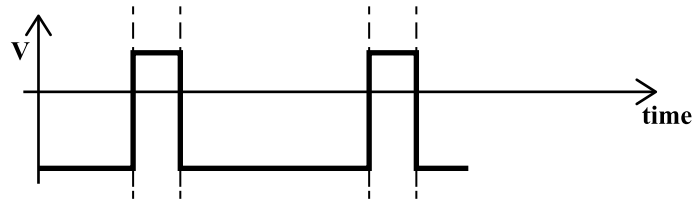
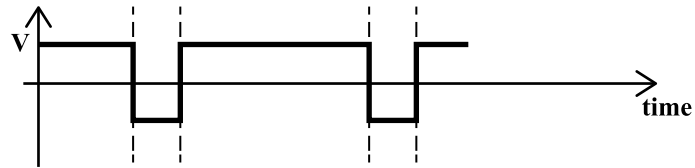
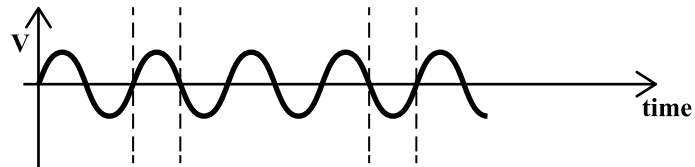

GO ON TO THE NEXT PAGE

Item 4 refers to the following diagram.

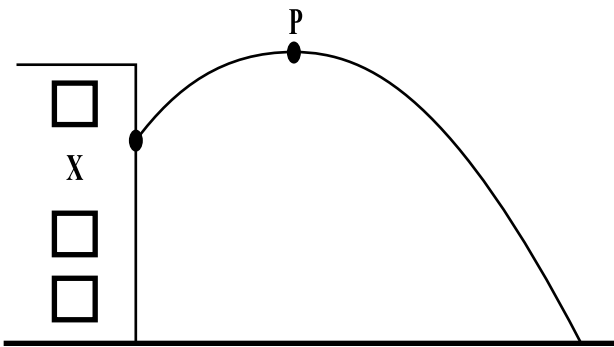

4. A stone is thrown from a building at X, and follows a parabolic path as shown in the diagram. The maximum height reached by the stone is P. The vertical component of acceleration of the stone is
- (A) maximum at P
 - (B) maximum at X
 - (C) the same at both X and P
 - (D) zero at P

Item 5 refers to the following diagram.

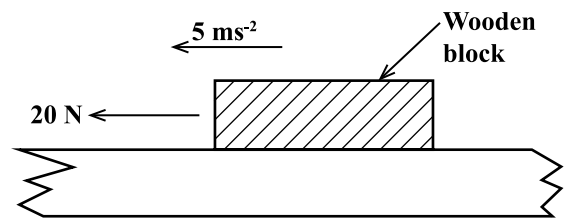

5. A wooden block of mass 0.80 kg is being pulled along a rough horizontal surface with a force of 20 N as shown above. The block experiences an acceleration of 5 ms⁻². What is the magnitude of the frictional force?
- (A) 24 N
 - (B) 20 N
 - (C) 16 N
 - (D) 4 N

Item 6 refers to the following diagram, which shows a projectile fired with a horizontal velocity, v , from the edge of a cliff. The height of the cliff is 6 metres.

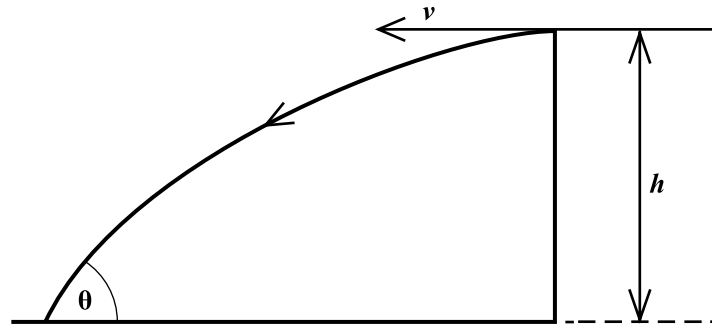

6. Which of the following pairs of values of v and h give the maximum value of Θ ?

	$v/\text{m s}^{-1}$	h/m
(A)	50	10
(B)	30	50
(C)	30	30
(D)	10	50

7. A monkey of mass 20 kg rides on a 40 kg trolley moving with a steady speed of 8 ms^{-1} along a flat surface. The monkey jumps vertically to grab the overhanging branch of a tree. At what speed will the trolley move off?

- (A) 12 ms^{-1}
(B) 8 ms^{-1}
(C) 5 ms^{-1}
(D) 0.33 ms^{-1}

8. The velocity of a body with kinetic energy E_k and mass m , is

- (A) $\frac{2E_k}{m}$
(B) $\sqrt{\frac{2E_k}{m}}$
(C) $\frac{E_k}{2m^2}$
(D) $\sqrt{\frac{2E_k^2}{m}}$

9. A parachutist is falling through air of uniform density from a great height. (g is the acceleration of free fall.)

Which of the following graphs show how his acceleration varies with time?

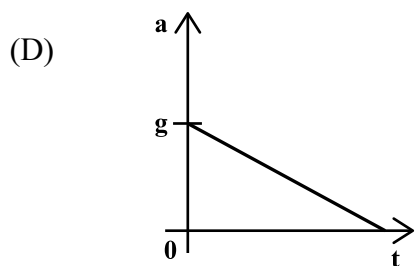
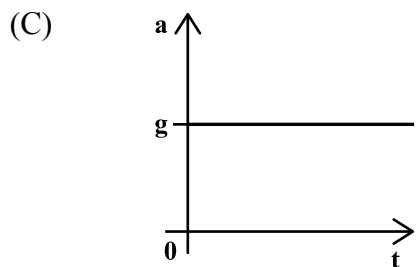
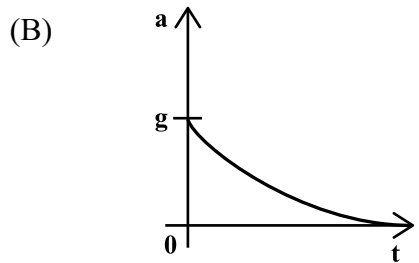
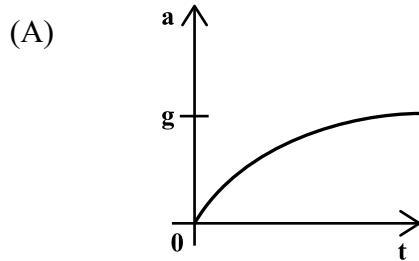

10. Two rocks are spun around in circular paths at the ends of strings of equal length. What quantity MUST be the same for both rocks if the tension in the strings are equal?

- (A) Mass
- (B) Speed
- (C) Acceleration
- (D) Kinetic energy

11. Aeroplane A is travelling at twice the speed of Aeroplane B. Plane A is half the mass of Aeroplane B. Which of the following statements is correct?

- (A) The two aeroplanes have the same kinetic energy
- (B) Aeroplane A has twice the kinetic energy of Aeroplane B
- (C) Aeroplane A has half the kinetic energy of Aeroplane B
- (D) Aeroplane A has one quarter of the kinetic energy of Aeroplane B

12. An object is rotated in a vertical circle with a constant angular velocity as shown in the diagram below.

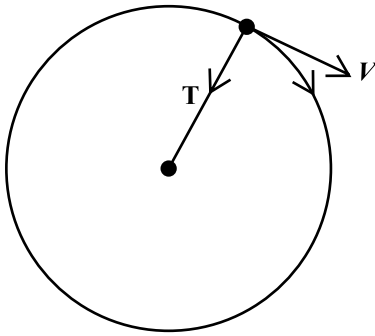

Which of the following quantities remain constant as the object moves round its circular path?

- I. The tension in the string
 - II. The acceleration of the object
 - III. The kinetic energy of the object
- (A) I and II only
 - (B) I and III only
 - (C) II and III only
 - (D) I, II and III
13. In a 100 m race, the winner finished in a time of 9.90 s and the fourth place sprinter finished 12 ms later. In what time did he finish the race?
- (A) 9.912 s
 - (B) 9.780 s
 - (C) 10.002 s
 - (D) 10.200 s

14. A geostationary satellite traces an orbit with angular velocity ω_s a distance r above the earth's surface. Which of the following quantities will be the same for both the satellite and the fixed point of the earth's surface?

- I. Speed
- II. Angular velocity
- III. Angular displacement

- (A) I and II only
- (B) I and III only
- (C) II and III only
- (D) I, II and III

15. Marcia needs to find the mass of her dog but he will not stay on the bathroom scale. So first she weighs herself, getting 47 ± 1 kg. Then she stands on the balance holding her dog and the reading becomes 64 ± 1 kg. From these readings the percentage error (or uncertainty) in the mass of the dog is

- (A) 1%
- (B) 2%
- (C) 6%
- (D) 12%

16. Which of the following CANNOT be demonstrated in sound waves?

- (A) Reflection
- (B) Diffraction
- (C) Polarisation
- (D) Interference

17. Which of the following gives the correct relationship between the intensity and amplitude of sound waves?

- (A) Intensity $\propto \frac{1}{\text{amplitude}}$
- (B) Intensity $\propto (\text{amplitude})^2$
- (C) Intensity $\propto \frac{1}{\text{amplitude}^2}$
- (D) Intensity \propto amplitude

18. The displacement-time and displacement-distance graphs for a transverse wave are shown below.

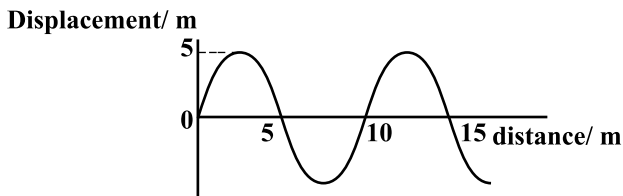
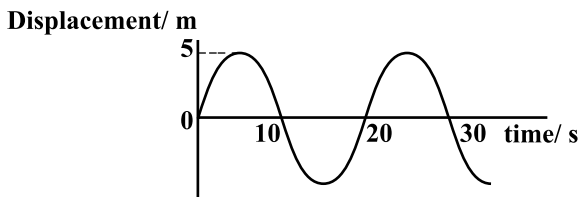

What is the wave speed?

- (A) 0.25 m s^{-1}
- (B) 0.5 m s^{-1}
- (C) 1.0 m s^{-1}
- (D) 2.0 m s^{-1}

19. For light passing from air to Material X, the refractive index is 1.3 and for light passing from air to Material Y, the refraction index is 1.5. Which of the following shows the speed of light in air, X and Y in **descending** order of magnitude? (fastest to slowest)

- (A) air, X, Y
- (B) air, Y, X
- (C) Y, air, X
- (D) X, Y, air

20. Light from a source is incident normally on a diffraction grating which has 2000 lines per mm. What is the wavelength of the light if the first order maximum makes an angle of 30° with the zero order?

- (A) 125 nm
- (B) 250 nm
- (C) 433 nm
- (D) 866 nm

21. A converging lens has a focal length of 12 cm. If an object is placed 20 cm from the lens, the image would be

- (A) 8 cm from the lens
- (B) 12 cm from the lens
- (C) 20 cm from the lens
- (D) 30 cm from the lens

22. The value of a possible wavelength for radiation in the visible region in the electromagnetic spectrum is

- (A) $5 \times 10^{-8} \text{ m}$
- (B) $5 \times 10^{-7} \text{ m}$
- (C) $5 \times 10^{-6} \text{ m}$
- (D) $5 \times 10^{-5} \text{ m}$

Item 23 refers to the following diagram.

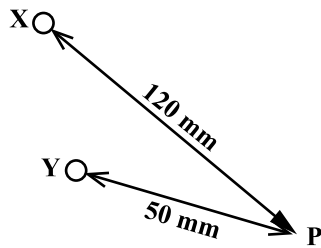

23. Two wave sources X and Y are positioned as shown 50 mm and 120 mm from a point P. The two sources produce waves which are in phase and which both have wavelengths of 20 mm. The phase difference between the waves arriving at P is

- (A) 45°
- (B) 90°
- (C) 180°
- (D) 360°

24. The magnitude of the threshold of hearing at 1 kHz is

- (A) 10^{-8} Wm^{-2}
- (B) 10^{-10} Wm^{-2}
- (C) 10^{-11} Wm^{-2}
- (D) 10^{-12} Wm^{-2}

25. Which of the following is NOT a condition necessary for the formation of stationary waves from two progressive waves?

- (A) Progressive waves must be superimposed.
- (B) Progressive waves must be travelling in opposite directions.
- (C) Progressive waves must be of the same amplitude and frequency.
- (D) The distance between the sources of progressive waves must be a whole number of wavelengths.

26. A glass tube of effective length 0.60 m is closed at one end. Given that the speed of sound in air is 300 ms^{-1} , the two LOWEST resonant frequencies are

- (A) 125 Hz, 250 Hz
- (B) 125 Hz, 375 Hz
- (C) 250 Hz, 375 Hz
- (D) 500 Hz, 750 Hz

Item 27 refers to the following diagram.

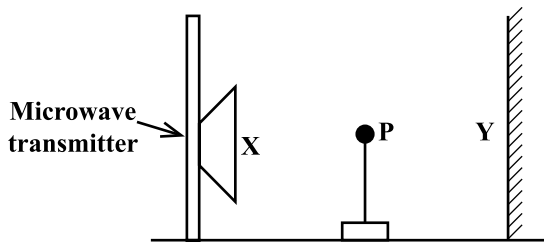

27. A microwave transmitter X sends radio waves to a metal sheet Y. A probe, P, between X and Y is moved from one node through 20 antinodes to a node 0.3 m away. What is the frequency of the microwaves emitted from X?

- (A) 3×10^{-2} Hz
- (B) 3×10^{-8} Hz
- (C) 2×10^{10} Hz
- (D) 1×10^{10} Hz

28. Which of the following quantities does NOT remain constant when a particle moves in simple harmonic motion?

- (A) Force
- (B) Amplitude
- (C) Total energy
- (D) Angular frequency

Item 29 refers to the following diagram.

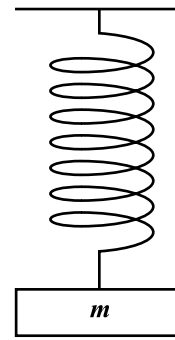

29. A mass, m , is attached to a vertical helical spring and displaced a distance "A" from equilibrium as shown in the diagram. The mass is released so that it oscillates with simple harmonic motion with angular frequency ω .

Which of the following expressions gives the variation of velocity, v , with time, t ?

- (A) $v = A \sin \omega t$
- (B) $v = A \cos \omega t$
- (C) $v = A \omega \sin \omega t$
- (D) $v = -A \omega^2 \sin \omega t$

Item 30 refers to the following diagram.

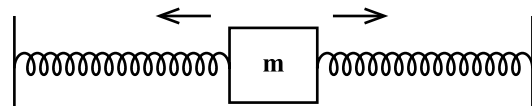

30. A mass m , undergoes horizontal simple harmonic motion under the action of two springs as shown. Its equation of motion is $\frac{-2k}{m}x$ and its amplitude is A.

What is its MAXIMUM kinetic energy?

- (A) $\frac{1}{2} kA^2/m$
- (B) $2 m^2 A^2/K$
- (C) $2 k^2A^2/m$
- (D) kA^2

GO ON TO THE NEXT PAGE

31. One fixed point on the thermodynamic temperature scale is identified by the

- (A) ice point of water
- (B) steam point of water
- (C) triple point of water
- (D) boiling point of water

32. Two bodies when in thermal equilibrium will have the same

- A pressure
- B temperature
- C kinetic energy
- D potential energy

33. The temperature of 50 g of liquid was raised by 60 K when it was used to cool a steel ball of mass 100 g from 150° C to 70° C. If the specific heat capacity of steel is 450 J/kg K, what is the specific heat capacity of the liquid?

- (A) 1200 J/kg K
- (B) 675 J/kg K
- (C) 300 J/kg K
- (D) 120 J/kg K

Item 34 refers to the following diagram.

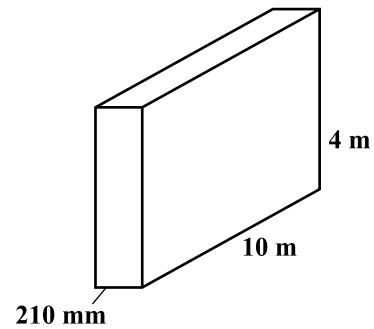

A brick wall 10 m long by 4 m high is insulated with a material of thermal conductivity $0.70 \text{ Wm}^{-1} \text{ K}^{-1}$. If the insulating material is 210 mm thick, the interface between the wall and material is at 95°C and the rate of heat flow into the interface is 4 kW, what is the temperature of the other end of the insulation?

- (A) 125° C
- (B) 98° C
- (C) 94.7° C
- (D) 65° C

35. What is the SI base unit for specific heat capacity?

- A $\text{kg}^2 \text{ m}^2 \text{ K}^{-1}$
- B $\text{m}^2 \text{ s}^{-1} \text{ K}$
- C $\text{m kg}^{-1} \text{ K}^1$
- D $\text{m}^2 \text{ s}^{-2} \text{ K}^{-1}$

36. What is the average kinetic energy of helium atoms at 27° C?

- (A) $2.8 \times 10^{-21} \text{ J}$
- (B) $2.5 \times 10^{-22} \text{ J}$
- (C) $6.2 \times 10^{-21} \text{ J}$
- (D) $5.6 \times 10^{-21} \text{ J}$

37. Which of the following is NOT an assumption of the kinetic theory of gases?

- (A) A gas consists of a large number of molecules.
- (B) The gas molecules are in constant, random motion.
- (C) The gas molecules collide in elastically with each other.
- (D) The duration of a collision is negligible when compared to the time interval between collisions.

38. A monatomic gas at 18°C and 1.2×10^5 Pa is contained in a vessel of capacity one cubic metre. What is the approximate number of atoms present?

- (A) 4×10^{26}
- (B) 3×10^{25}
- (C) 6×10^{23}
- (D) 1×10^{24}

Item 39 refers to the following P-V diagram, which represents a gas being taken through three processes, 1 to 2, 2 to 3 and 3 to 1 to complete the cycle.

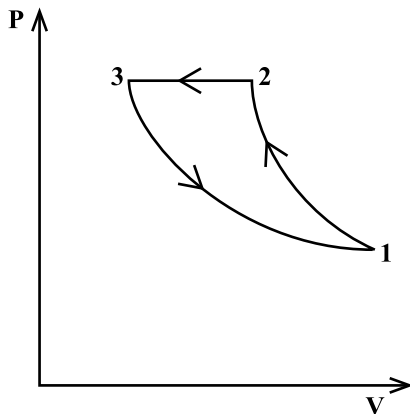

39. In which process(es) is work being done on the gas?

- (A) 1 to 2 and 2 to 3
- (B) 2 to 3 and 3 to 1
- (C) 3 to 1 only
- (D) 2 to 3 only

Item 40 refers to the following diagram.

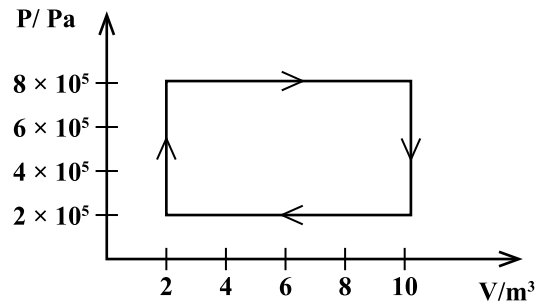

40. An ideal gas initially at 2 m^3 and a pressure of 2.0×10^5 Pa is taken through a cycle as shown in the diagram above.

The work done on the gas in the complete cycle is

- (A) $+6.4$ MJ
- (B) $+4.8$ MJ
- (C) -4.8 MJ
- (D) -6.4 MJ

A cube of side x cm is submerged in a fluid of density ρ , at a depth h below the surface of the fluid as shown in the following diagram.

41. A cube of side x cm is submerged in a fluid of density ρ , at a depth h below the surface of the fluid as shown in the following diagram.

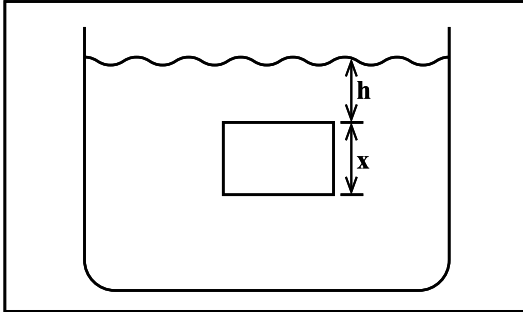

What is the pressure experienced by the bottom surface of the cube?

- (A) $h\rho g$
(B) $x\rho g$
(C) $(x - h)\rho g$
(D) $(x + h)\rho g$
42. A steel wire of length 3 m and uniform cross-sectional area 0.1mm^2 is used in an experiment to determine the Young's modulus of steel. The gradient of the force-extension graph obtained is $6.7 \times 10^3 \text{ Nm}^{-1}$.

What is Young's modulus of steel?

- (A) $2.0 \times 10^{11} \text{ Pa}$
(B) $2.0 \times 10^8 \text{ Pa}$
(C) $4.5 \times 10^{11} \text{ Pa}$
(D) $2.2 \times 10^{10} \text{ Pa}$

43. Which of the following equations is correct?

(A) $Stress = \frac{length}{extension}$

(B) $Strain = \frac{extension}{length}$

(C) $Strain = \frac{force}{area}$

(D) $Stress = \frac{area}{force}$

44. The equation for the net rate of heat radiation between two bodies is given as

(A) $P = \sigma AT^4$

(B) $P = \sigma A(T_1 - T_2)$

(C) $P = \sigma A(T_1 - T_2)^4$

(D) $P = \sigma A(T_1^4 - T_2^4)$

Item 45 refers to the following force-extension graph for three different materials, X, Y and Z.

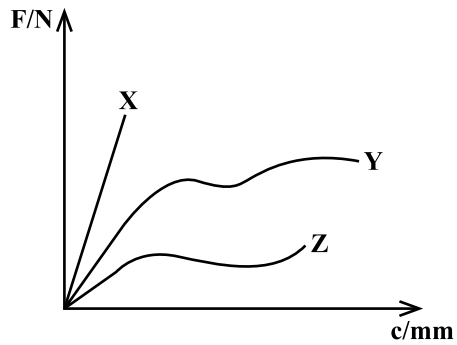

45. Which of the following options correctly labels the graphs?

	X	Y	Z
(A)	brittle	polymeric	ductile
(B)	ductile	polymeric	brittle
(C)	brittle	ductile	polymeric
(D)	ductile	brittle	polymeric

END OF TEST

IF YOU FINISH BEFORE TIME IS CALLED, CHECK YOUR WORK ON THIS TEST.

Question	Module/Syllabus Reference	Profile	Key
1	1.2.1	KC	B
2	1.1.3	KC	C
3	1.3.2	UK	D
4	1.3.6	KC	C
5	1.4.2	UK	C
6	1.3.6	KC	D
7	1.3.11	UK	A
8	1.1.7	UK	B
9	1.3.2	KC	B
10	1.3.20	UK	D
11	1.5.2	UK	B
12	1.3.21	KC	C
13	1.2.3	KC	A
14	1.3.26	KC	C
15	1.1.9	UK	D
16	2.1.1	KC	C
17	2.1.5	KC	B
18	2.1.4	UK	B
19	2.3.3	KC	A
20	2.3.8	UK	B
21	2.3.11	UK	D
22	2.3.2	KC	B
23	2.4.2	UK	C
24	2.4.9	KC	D
25	2.4.12	KC	D
26	2.5.1	UK	B
27	2.4.12	UK	D
28	2.5.4	KC	A
29	2.5.2	KC	C
30	2.5.8	UK	D
31	3.1.4	KC	C
32	3.2.1	KC	B
33	3.2.4	UK	A
34	3.3.2	UK	D
35	3.2.3	KC	D
36	3.4.8	UK	C
37	3.4.4	KC	C
38	3.4.3	UK	B
39	3.5.4	KC	A
40	3.5.4	UK	C
41	3.6.3	KC	D
42	3.6.9	UK	A
43	3.6.9	KC	B
44	3.3.7	UK	D
45	3.6.7, 6.11	KC	C

**C A R I B B E A N E X A M I N A T I O N S C O U N C I L****C A R I B B E A N A D V A N C E D P R O F I C I E N C Y E X A M I N A T I O N [®]****P H Y S I C S****UNIT 1 – Paper 02***2 hours 30 minutes***SPECIMEN PAPER****READ THE FOLLOWING INSTRUCTIONS CAREFULLY.**

1. This paper consists of THREE questions. Answer ALL questions.
2. Write your answers in the spaces provided in this booklet.
3. Do NOT write in the margins.
4. ALL WORKING MUST BE SHOWN in this booklet.
5. You may use a silent, non-programmable calculator to answer questions, but you should note that the use of an inappropriate number of figures in answers will be penalized.
6. If you need to rewrite any answer and there is not enough space to do so on the original page, you must use the extra lined page(s) provided at the back of this booklet. **Remember to draw a line through your original answer.**
7. **If you use the extra page(s) you MUST write the question number clearly in the box provided at the top of the extra page(s) and, where relevant, include the question part beside the answer.**

DO NOT TURN THIS PAGE UNTIL YOU ARE TOLD TO DO SO.

LIST OF PHYSICAL CONSTANTS

Universal gravitational constant	G	=	$6.67 \times 10^{-11} \text{ N m}^2 \text{ kg}^{-2}$
Acceleration due to gravity	g	=	9.81 m s^{-2}
1 Atmosphere	atm	=	$1.00 \times 10^5 \text{ N m}^{-2}$
Boltzmann's constant	k	=	$1.38 \times 10^{-23} \text{ J K}^{-1}$
Density of water	ρ_w	=	$1.00 \times 10^3 \text{ kg m}^{-3}$
Specific heat capacity of water	C_w	=	$4200 \text{ J kg}^{-1} \text{ K}^{-1}$
Specific latent heat of fusion of ice	L_f	=	$3.34 \times 10^5 \text{ J kg}^{-1}$
Specific latent heat of vaporization of water	L_v	=	$2.26 \times 10^6 \text{ J kg}^{-1}$
Avogadro's constant	N_A	=	6.02×10^{23} per mole
Molar gas constant	R	=	$8.31 \text{ J K}^{-1} \text{ mol}^{-1}$
Stefan-Boltzmann's constant	σ	=	$5.67 \times 10^{-8} \text{ W m}^{-2} \text{ K}^{-4}$
Speed of light in free space (vacuum)	c	=	$3.00 \times 10^8 \text{ m s}^{-1}$
Speed of sound in air	c	=	340 m s^{-1}
Planck's constant	h	=	$6.626 \times 10^{-34} \text{ J s}$
Triple point temperature	T_{tr}	=	273.16 K
1 tonne	t	=	1000 kg

GO ON TO THE NEXT PAGE

Answer ALL questions.

Write your answers in the spaces provided in this booklet.

1. The data in Table 1 were collected in a terminal velocity experiment. Small metal spheres were timed over a distance of 80.0 cm as they fell at constant velocity in thick engine oil.

TABLE 1. DATA FROM TERMINAL VELOCITY EXPERIMENT

Radius r/mm	Time/s	Velocity $v/\text{cm s}^{-1}$	$\lg (v/\text{cm s}^{-1})$	$\lg (r/\text{mm})$
1.00	44.8			
1.49	20.1			
2.02	11.3			
2.51	7.2			
2.99	5.0			

- (a) Explain the term ‘terminal velocity’.

.....
.....

[1 mark]

- (b) Draw a force diagram to explain why the velocity is constant.

[2 marks]

- (c) Complete Table 1 by inserting the missing values in Columns 3, 4 and 5.

[3 marks]

GO ON TO THE NEXT PAGE

- (d) Using the grid provided on page 7, plot a suitable graph to find the value of n .
(Note that it is NOT necessary to convert the units to metres.)

.....
.....
.....
.....
.....
.....
.....
.....
.....

[4 marks]

- (e) Write the equation of the graph you have drawn in Part (d).

.....
.....

[1 mark]

- (f) What are the MOST likely values of the constants n and k ?

.....
.....
.....
.....
.....
.....
.....
.....
.....

[4 marks]

GO ON TO THE NEXT PAGE

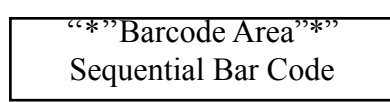

DO NOT WRITE IN THIS AREA

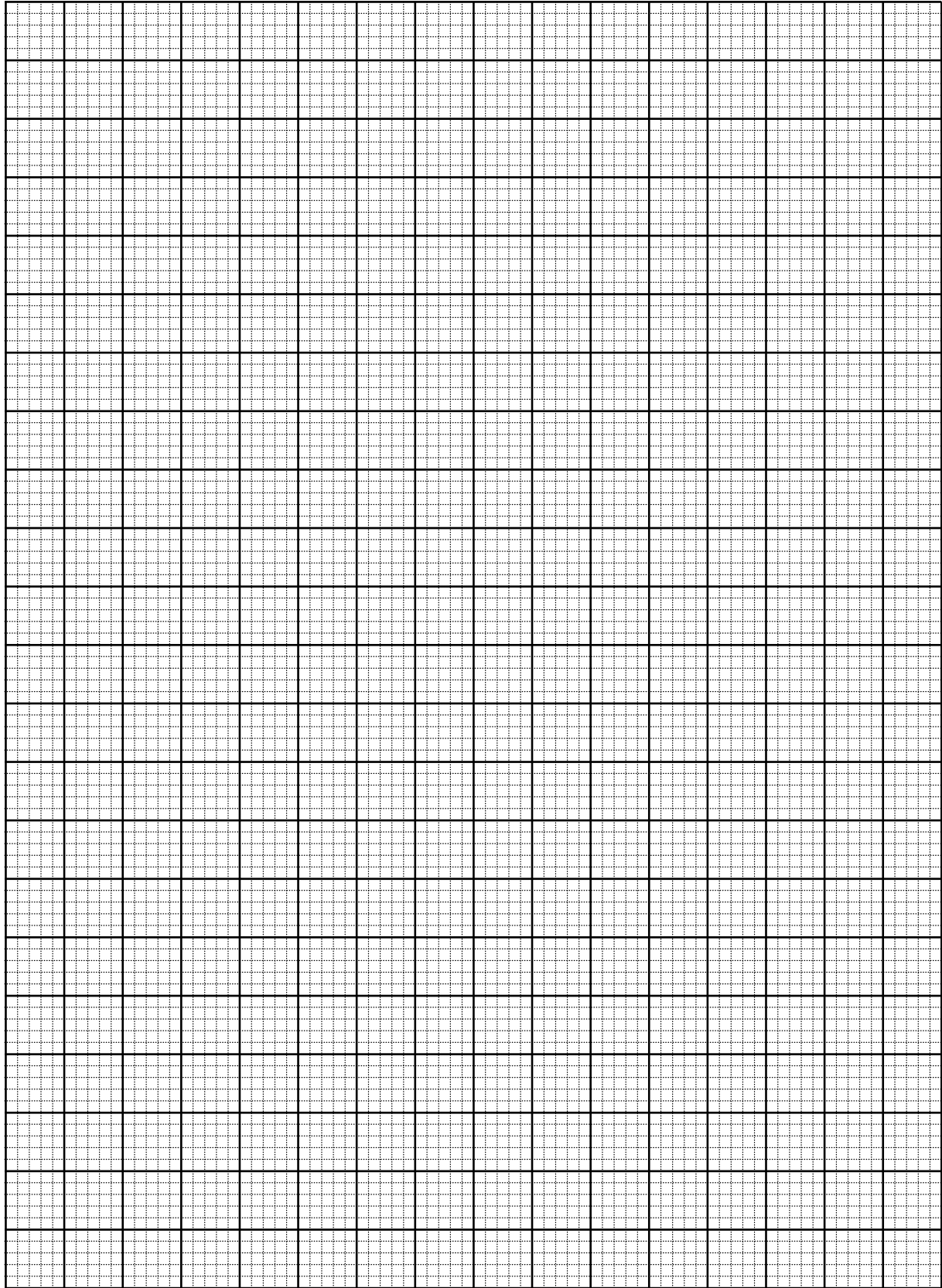

DO NOT WRITE IN THIS AREA

DO NOT WRITE IN THIS AREA

DO NOT WRITE IN THIS AREA

GO ON TO THE NEXT PAGE

“*”Barcode Area”*”
Sequential Bar Code

- (g) Using Newton's laws, explain how the propeller of a light aeroplane similar to the one shown in Figure 1 is able to provide forward thrust.

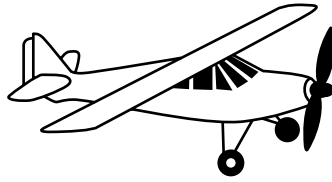

Figure 1. Light aeroplane

.....

.....

.....

.....

.....

.....

[3 marks]

DO NOT WRITE IN THIS AREA

- (h) In order to turn, an aeroplane must “bank” as shown in Figure 2, so that the lift force is no longer vertical. (Assume that the aeroplane remains in level flight and travels at constant speed.)

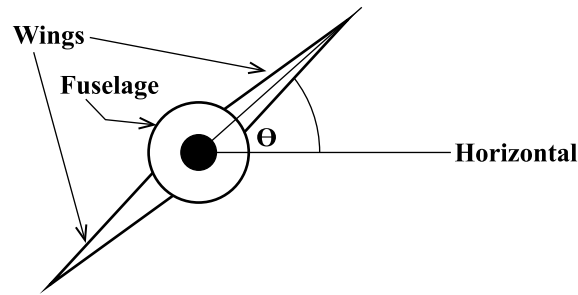

Figure 2. Banking aeroplane

- (i) Draw a diagram similar to that in Figure 2, with arrows to show the direction of the external forces acting on the aeroplane as it turns. On a second similar diagram, show the direction of the RESULTANT force acting on the plane.

[4 marks]

GO ON TO THE NEXT PAGE

- (ii) Calculate the radius of the circular path for a plane of mass 3 000 kg with a horizontal speed of 120 km per hour, if the resultant force acting is 16 000 N.

.....
.....
.....
.....
.....
.....
.....
.....

[4 marks]

- (iii) Find the size of the lift force on the plane and the banking angle θ .

.....
.....
.....
.....
.....
.....
.....
.....

[4 marks]

Total 30 marks

GO ON TO THE NEXT PAGE

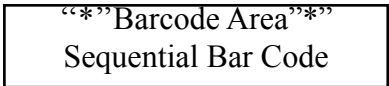

DO NOT WRITE IN THIS AREA

2. (a) An oscillating system has a period, T , which is related to the length, l , of the suspension by the equation $T = al^n$, where a and n are constants. Table 2 shows the time periods obtained as the length was changed.

(i) Complete Table 2 by inserting the values for $\lg l$ and $\lg T$.

Table 2

l/mm	2.31	292	411	515	859
T/s	0.94	1.06	1.27	1.42	1.86
$\lg l$					
$\lg T$					

[3 marks]

(ii) Express the above equation in the form of a straight line.

.....

.....

.....

.....

[2 marks]

(iii) Using the grid provided on page 13, plot a suitable graph to determine the values of a and n . [4 marks]

(b) Use the graph to find the value of n .

.....
.....
.....
.....

[2 marks]

(c) Use your value of n to find a .

.....
.....
.....
.....

[2 marks]

(d) Suggest an accurate means of determining the time period, T .

.....
.....
.....
.....

[2 marks]

(e) (i) Define the 'refractive index' of a medium.

.....
.....
.....
.....

[2 marks]

GO ON TO THE NEXT PAGE

DO NOT WRITE IN THIS AREA

DO NOT WRITE IN THIS AREA

DO NOT WRITE IN THIS AREA

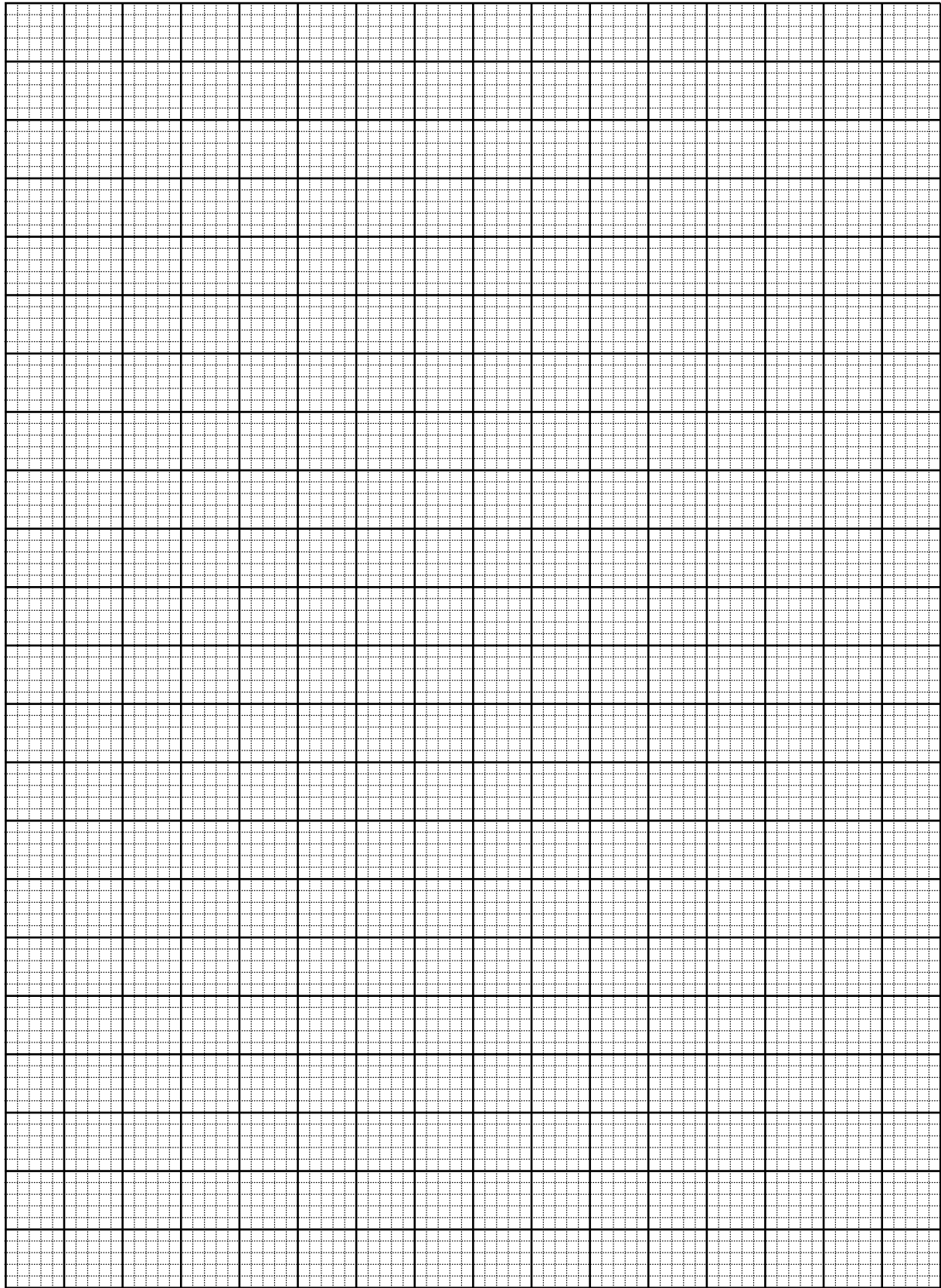

GO ON TO THE NEXT PAGE

“*”Barcode Area”
Sequential Bar Code

(ii) Define the 'critical angle'.

.....
.....
.....
.....

[2 marks]

(iii) State what is meant by 'total internal reflection', explaining the significance of the word 'total'.

.....
.....
.....
.....

[3 marks]

(f) Figure 3 shows a prism of index of refraction of 1.45 in air.

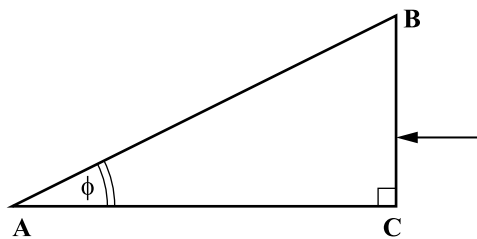

Figure 3

(i) Determine the critical angle for light travelling from the prism into air.

.....
.....
.....
.....

[2 marks]

GO ON TO THE NEXT PAGE

- (ii) A ray of light is incident perpendicular to the surface BC, as shown in Figure 3. If total internal reflection occurs, determine the maximum angle ϕ of the prism.

.....

.....

.....

.....

.....

.....

[3 marks]

- (g) The prism in part (f) is immersed in a liquid. Find the ratio of the speed of light in the prism to the speed of light in the liquid, if the critical angle for light travelling from the prism into the liquid is 32.0° .

.....

.....

.....

.....

.....

.....

[3 marks]

Total 30 marks

GO ON TO THE NEXT PAGE

3. (a) A cylinder with a leak proof movable piston is filled with 0.1 moles of Helium gas. The piston moves gradually outwards at a constant temperature and the pressures at particular volumes are noted in Table 3.

Pressure /kPa	Volume /cm ³
800	300
600	400
480	500
400	600
340	700
300	800
270	900
240	1000
220	1100
200	1200

Using the results in Table 3, plot a graph of pressure against volume on the grid on page 17. Start both axes at the origin. [5 marks]

GO ON TO THE NEXT PAGE

(b) (i) Prove that the process is isothermal.

.....
.....
.....
.....
.....
.....

[3 marks]

(ii) Calculate the temperature.

.....
.....
.....
.....
.....
.....

[3 marks]

(c) State the first law of thermodynamics and explain each of the terms.

.....
.....
.....
.....
.....
.....

[4 marks]

GO ON TO THE NEXT PAGE

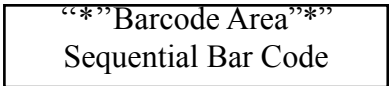

DO NOT WRITE IN THIS AREA

- (d) Calculate the values for EACH of the terms stated in part (c), for the helium going through the expansion process from 300 cm^3 to 1200 cm^3 .

.....

.....

.....

.....

.....

.....

.....

.....

.....

.....

.....

.....

.....

.....

.....

.....

.....

.....

.....

.....

.....

.....

.....

[5 marks]

- (e) Explain why heat was supplied to the gas.

.....

.....

.....

.....

.....

.....

.....

.....

.....

.....

.....

[2 marks]

- (f) Using the kinetic theory of gases, briefly explain
- (i) what accounts for the pressure on the wall of the container when the helium gas fills it.

.....

.....

.....

.....

.....

.....

.....

.....

.....

.....

.....

[2 marks]

GO ON TO THE NEXT PAGE

(ii) why does the pressure decrease with increasing volume?

.....
.....
.....
.....

[2 marks]

(g) Given that the relative molar mass of Helium is 4.0 gmol^{-1} , calculate the r.m.s. speed of the Helium molecules at the end point. ($p = 200 \text{ kPa}$; $V = 1200 \text{ cm}^3$).

.....
.....
.....
.....
.....
.....
.....
.....
.....

[4 marks]

Total 30 marks

END OF TEST

IF YOU FINISH BEFORE TIME IS CALLED, CHECK YOUR WORK ON THIS TEST.

DO NOT WRITE IN THIS AREA

EXTRA SPACE

If you use this extra page, you **MUST** write the question number clearly in the box provided.

Question No.

Dotted lines for writing the answer.

DO NOT WRITE IN THIS AREA

Barcode Area Sequential Bar Code

C A R I B B E A N E X A M I N A T I O N S C O U N C I L

ADVANCED PROFICIENCY EXAMINATION

PHYSICS

UNIT 1 - PAPER 02

MARK SCHEME

2017

Question 1

- (a) When a body is released in a viscous liquid it accelerates first, then its velocity soon reaches a steady value called the terminal velocity.

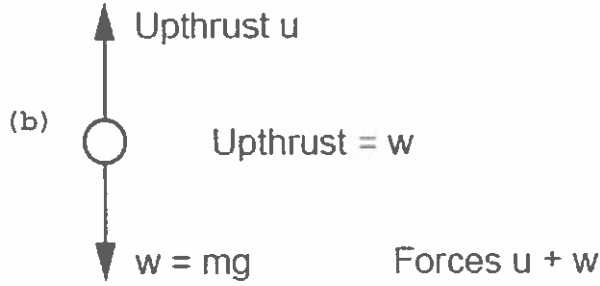

1 KC mark for each correct label

- (c) Completing Table 1

Radius r/mm	Time t/s	Velocity v/cms^{-1}	\lg (v/cms^{-1})	\lg (r/mm)
1.00	44.8	1.79	0.252	0.000
1.49	20.1	3.98	0.600	0.173
2.02	11.3	7.08	0.850	0.305
2.51	7.2	11.1	1.045	0.400
2.99	5.0	16.1	1.204	0.476

- 1 UK mark for each error

- (d) For plotting graph

Labelled axes (quantity and unit) (1)
 5 correct points (3)
 4 correct points (Award 2 marks only)
 2-3 correct points (Award 1 mark only)
 < 2 correct points (0)

KC	UK	XS
1		
2		
	3	
		4

Question 1 continued

(e) $lgv = nlgr + lgk$

(f) Gradient calculation (1)

$n = 2$ (1)

Intercept measurement (1), calculating k (1)(g) Newton's 2nd law: force on the air equals its rate of change of momentum (1)Newton's 3rd : plane pushes back air, therefore pushes the plane forward (1)

Using both laws to explain (1)

(h)

(i)

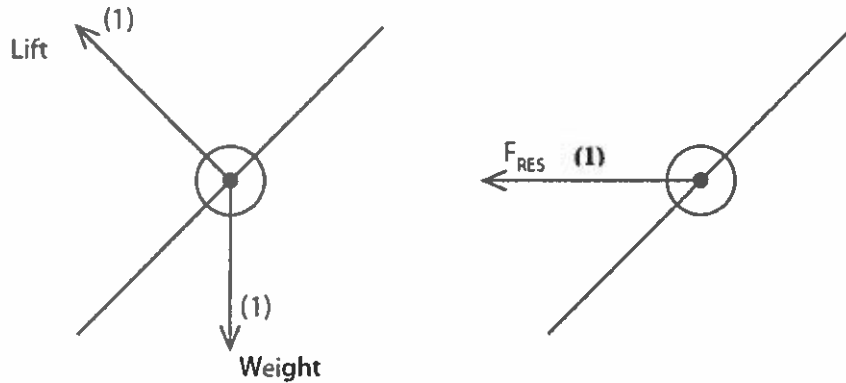

Showing two forces at correct angle (1)

[-1 mark for each extra arrow added to a diagram]

(ii) $F = \frac{mv^2}{R} \Rightarrow R = \frac{mv^2}{F} \text{ (1)} = \frac{3000 v^2}{16000} \text{ (1)}$

$$[v = \frac{120\,000\text{m}}{3600\text{s}} = 33.3 \text{ ms}^{-1}] \text{ (1)}$$

$$\text{So } R = \frac{3\,000}{16\,000} \times (33.3)^2 = 208 \text{ m} \text{ (1)}$$

KC	UK	XS
	1	
	3	1
	3	
	4	
	4	

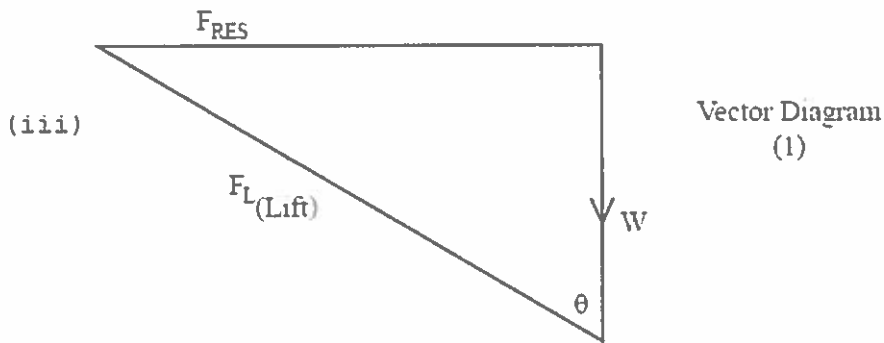
Question 1 continued

$$\tan \theta = \frac{F_{RES}}{W} = \frac{16\,000}{3000 \times 9.81} = 0.544$$

$$\theta = \tan^{-1}(0.544) \gg \theta = 28.5^\circ \quad (1)$$

$$F_{RES} = F_L \sin \theta \quad (1)$$

$$F_L = \frac{16\,000}{\sin 28.5} = 33.5 \times 10^3 \text{ N} \quad (1)$$

Total 30 marks

KC	UK	XS
	4	
10	15	5

Question 2

- (a) (i) Correctly completing data (3)
- (ii) $\log T = \log A + n \log l$ (2)
- (iii) Graph of $\log T / \log l$
- Suitable scales (1)
- 5 correct points (2)
- 3 - 4 correct points (1)
- < 3 correct points (0)
- Line of best fit (1)
- (b) Gradient = $n = 0.52$ Read off (1)
- Calculation (1)
- (c) $T = al^{0.52}$
- $\log T = \log a + 0.52 \log l$
- $0.302 = \log a + 0.52 \times 3.0$ (1)
- $\log a = -1.26;$
- $a = 0.055$ (1)
- (d) Many (N) oscillations observed, T total, and
- Time, $T, = \frac{T \text{ total}}{N}$ (1)
- Repeat timing to check (1)
- (e) (i) The refractive index of a medium is the ratio of the sine of the angle of incidence to the sine of the angle of refraction (in the medium) (1) of the ray when traveling from air to the medium (1).
- (ii) The critical angle is the angle of incidence for a ray traveling from a dense to a less dense medium (1), for an angle of refraction of 90° (1).
- (iii) Total internal reflection occurs when the critical angle has been exceeded (1). The ray is reflected internally (1) from the medium boundary. Only when moving from a dense to a less dense medium (1).

KC	UK	XS
2	3	4
	1	1
	2	
	2	
2		
	2	
3		

Question 2

(i) $n = 1.45$ (1)

(f)
$$\sin c = \frac{1}{1.45} = 0.689$$

$$C = 43.6^\circ$$
 (1)

(ii)

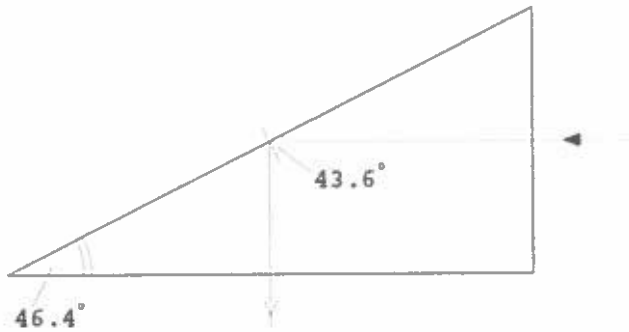
**For Total Internal Reflection**

Angle of incidence must be at least 43.6° (1)
 i.e. angle of prism = $90 - 43.6 = 46.4^\circ$ (1)

If critical angle = 32°
 then $n = \frac{1}{\sin C}$
 $= 1.89$ (1)

(g) $C_1/C_2 = n_2/n_1$ (1)
 $= 1.89/1.45 = 1.30$ (1)

KC	UK	XS
1		
	3	
	3	
Total 30 marks	10	15
	5	

Question 3

(a)

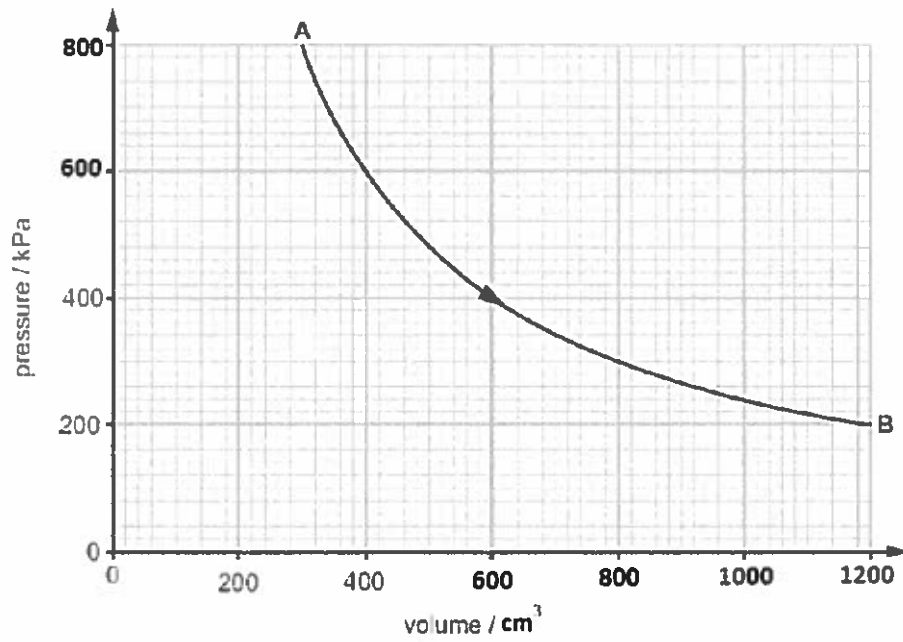

- Labeled axes (quantity and unit) (1)
 Appropriate scale (1)
 8-10 points correctly plotted (2)
 5-7 points correctly plotted (1)
 <5 points correctly plotted (0)
- Best fit curve (1)

KC	UK	XS
		5

Question 3

- (b)
- (i) Showing at least 3 calculations of pV , indicating that the values are equal (2)
Stating that in an isothermal process the product $pV = \text{constant}$ (1)
- (ii) $pV = nRT$ (1)
 $T = \frac{pV}{nR}$
- $$T = \frac{800 \times 10^3 \times 300 \times 10^{-6}}{0.1 \times 8.31} \quad (1)$$
- $$T = 289 \text{ K} \quad (1)$$
- (c) $\Delta U = \Delta Q + \Delta W$ (1)
- ΔU - change in internal energy
 ΔQ - heat supplied to the gas
 ΔW - work done on the gas } (3)
- (d) $\Delta U = 0 \text{ J}$ (1)
- ΔW = area under graph (1)
blocks = 820
Area of 1 block = 0.4 J
Total area = 328 J (1)
 $\Delta W = -328 \text{ J}$ (1)
 $\Delta Q = 328 \text{ J}$ (1)
- (e) In expanding, the gas is doing work and therefore losing energy. This means that the gas cools as it expands (1)
- In order for the temperature to remain the same, heat energy must be added to the gas to replace what is lost during the expansion process (1).
- (f)
- (i) Gas particles are in constant random motion. They collide with each other and the walls of the container, exerting a force (1).
The pressure is because of the continuous bombardment (force) by the particles on the walls (1).

KC	UK	XS
	3	
1		
	2	
	4	
	5	
	2	
2		

Question 3

- (ii) As the volume of the container increases, there is more space for the particles to move in, therefore, there are less frequent collisions with the walls of the container (1).
This means that there will be a smaller resultant force exerted on the walls and therefore a smaller pressure (1).

(g) $m = 0.1 \times 4 \times 10^{-3}$

$m = 4 \times 10^{-4} \text{ kg (1)}$

$pV = Nm\langle c^2 \rangle \quad (1)$

$$\langle c^2 \rangle = \frac{200 \times 10^3 \times 1200 \times 10^{-6} \times 3}{4 \times 10^{-4}}$$

$\langle c^2 \rangle = 1.8 \times 10^6 \text{ m}^2\text{s}^{-2} \quad (1)$

r.m.s. $= 1.8 \times 10^6$
 $= 1341 \text{ m/s (1)}$

KC	UK	XS
2		
1		
	3	
10	15	5

Total 30 marks

SPEC 2017/02138032



TEST CODE 02138032

CARIBBEAN EXAMINATIONS COUNCIL

CARIBBEAN ADVANCED PROFICIENCY EXAMINATION®

PHYSICS

UNIT 1 – Paper 032

ALTERNATIVE TO SCHOOL-BASED ASSESSMENT

2 hours

READ THE FOLLOWING INSTRUCTIONS CAREFULLY.

1. This paper consists of THREE questions. Answer ALL questions.
2. Write your answers in the spaces provided in this booklet.
3. Do NOT write in the margins.
4. Where appropriate, ALL WORKING MUST BE SHOWN in this booklet.
5. You may use a silent, non-programmable calculator to answer questions, but you should note that the use of an inappropriate number of figures in answers will be penalized.
6. You are advised to take some time to read through the paper and plan your answers.
7. If you need to rewrite any answer and there is not enough space to do so on the original page, you must use the extra lined page(s) provided at the back of this booklet. **Remember to draw a line through your original answer.**
8. **If you use the extra page(s) you MUST write the question number clearly in the box provided at the top of the extra page(s) and, where relevant, include the question part beside the answer.**

DO NOT TURN THIS PAGE UNTIL YOU ARE TOLD TO DO SO.

Copyright © 2017 Caribbean Examinations Council
All rights reserved.

02138032/CAPE/SPEC 2017

“*”Barcode Area”*”
Sequential Bar Code

Answer ALL questions.

Write your answers in the spaces provided in this booklet.

1. (a) In this experiment, you will investigate the relationship between the period of oscillation of a cantilever and the mass attached at its end; and use this relationship to determine the Young modulus of wood.

You are provided with the following pieces of apparatus:

- G clamp
- A metre ruler
- Six 100-g slotted masses
- Stopwatch
- Pencil or biro
- Thick rubber band
- Vernier caliper

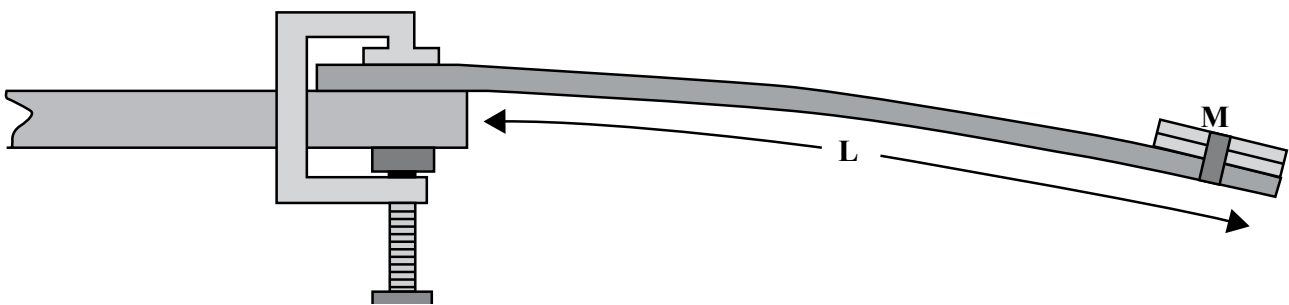

Figure 1. Diagram of set-up of apparatus

Procedure:

1. Using your Vernier caliper, measure and record the values for the width, W , and thickness, t , of the metre ruler.
2. Set up the apparatus as shown in Figure 1 with one end securely clamped to the bench. Ensure that the length, L , of the metre ruler is set to 90 cm.
3. Using your rubber band, secure a 100-g mass to the end of the ruler. Ensure that the masses line up exactly with the end of the ruler.
4. Displace the ruler slightly and record the time for 15 oscillations. Repeat this step to find an average value.
5. Add another 100-g mass to the end of the ruler. Secure with a rubber band and record the time for 15 oscillations.
6. Repeat steps 4 and 5 until you have completed the oscillations with 600 g on the end of the ruler.
7. Record your measurements in Table 1.
8. Determine the values of the period, T , $\lg m$ and $\lg T$ and record these values in Table 1.

GO ON TO THE NEXT PAGE

Results:

Width (W) of ruler

Thickness (t) of ruler.....

TABLE 1: RESULTS OF EXPERIMENT

Mass on end of ruler (m)/ kg	Time for 15 oscillations /s			Period (T)/s	lg m	lg T
	Trial #1	Trial #2	Average			
0.1						
0.2						
0.3						
0.4						
0.5						
0.6						

[2 marks]

- (b) The period of a cantilever is given by an equation of form $T = am^b$ where 'a' is a constant that depends on the other physical properties of the set up i.e. the dimensions of the ruler.

Plot a graph of lg T vs lg m, on the grid provided on page 6.

[7 marks]

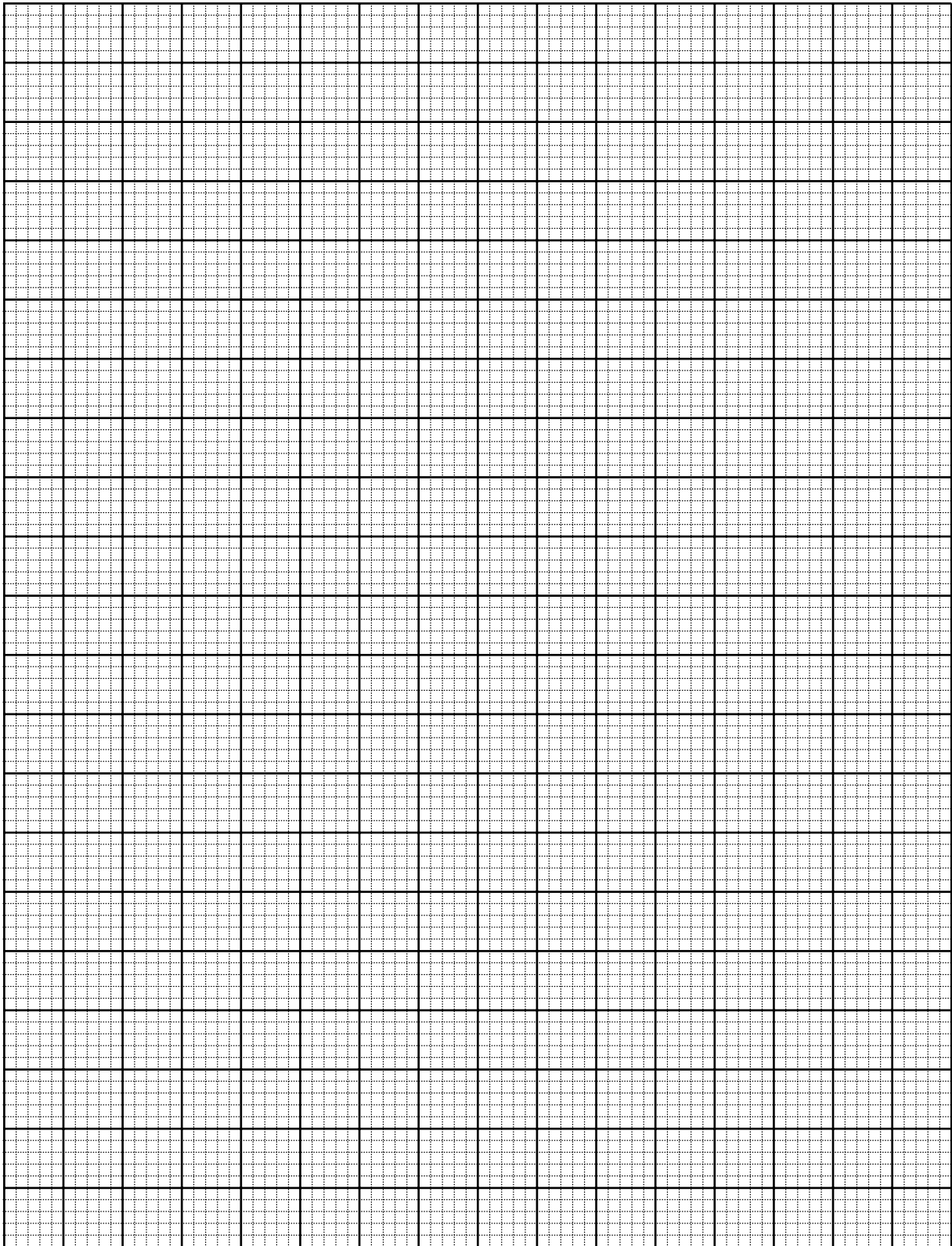

DO NOT WRITE IN THIS AREA

DO NOT WRITE IN THIS AREA

DO NOT WRITE IN THIS AREA

GO ON TO THE NEXT PAGE

“*”Barcode Area*”
Sequential Bar Code

(c) From your graph, determine the values of

(i) **b**

.....
.....
.....
.....

[3 marks]

(ii) **a**

.....
.....
.....
.....

[2 marks]

(d) Rewrite the equation in (b) with the calculated values of **a** and **b**.

.....
.....

[1 mark]

Total 15 marks

DO NOT WRITE IN THIS AREA

2. Table 2 represents the data obtained from a Young's Modulus experiment.

TABLE 2: VALUES OF FORCE AND EXTENSION

Force (F) /N	1.9	6.08	9.12	9.88	11.59	14.06
Extension(e)/m	0.01	0.032	0.048	0.052	0.061	0.074

The original length of the wire used in the experiment was 1.85 m and the diameter of the wire was 2.5 mm.

The Young's Modulus, E , of the wire is given by the equation

$$E = \frac{F/A}{e/L}$$

where F is the force on the wire, A is the cross sectional area of the wire, e is the extension and L is the original length of the wire.

(a) On the grid provided on page 9, plot a graph of force versus extension.

[7 marks]

GO ON TO THE NEXT PAGE

DO NOT WRITE IN THIS AREA

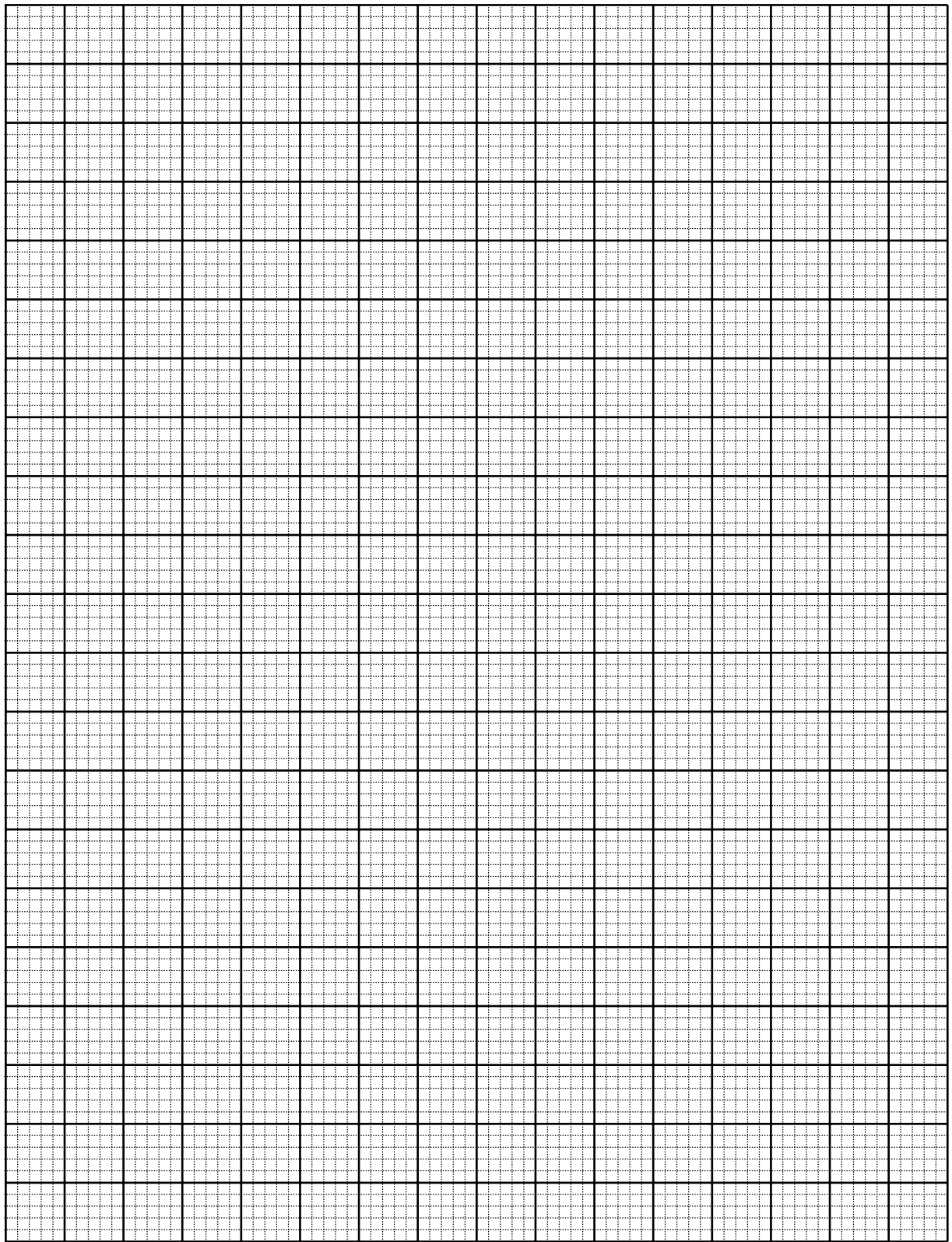

GO ON TO THE NEXT PAGE

“*”Barcode Area”*”
Sequential Bar Code

- (b) Use your graph to determine the Young's Modulus of the wire.

.....

.....

.....

.....

.....

.....

.....

.....

.....

.....

.....

.....

.....

.....

.....

.....

.....

.....

.....

.....

.....

[8 marks]

Total 15 marks

DO NOT WRITE IN THIS AREA DO NOT WRITE IN THIS AREA DO NOT WRITE IN THIS AREA

3. A student is asked to investigate the variation of light intensity with the thickness of glass, given the following apparatus. Each glass slide is covered with automotive tint.

List of apparatus:

- Glass slides 5 inches x 5 inches
- Light intensity meter
- Light source
- Meter rule
- Matt black card
- Micrometer screw gauge

Design an experiment to investigate the variation of light intensity with the thickness of glass. Write your answers under the following headings.

(a) Identification of variables

.....
.....
.....
.....
.....
.....

[3 marks]

(b) Set up of apparatus

.....
.....
.....
.....
.....

[3 marks]

GO ON TO THE NEXT PAGE

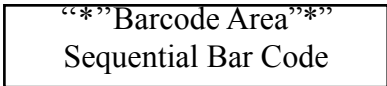

(c) Procedure

.....

.....

.....

.....

.....

.....

.....

.....

.....

.....

[4 marks]

(d) Results

.....

.....

.....

.....

.....

[3 marks]

(e) Conclusion

.....

.....

.....

[2 marks]

Total 15 marks

GO ON TO THE NEXT PAGE

DO NOT WRITE IN THIS AREA

EXTRA SPACE

If you use this extra page, you MUST write the question number clearly in the box provided.

Question No.

.....

.....

.....

.....

.....

.....

.....

.....

.....

.....

.....

.....

.....

.....

.....

.....

.....

.....

.....

.....

.....

02138032/CAPE/SPEC 2017

“*” Barcode Area “*”
Sequential Bar Code

DO NOT WRITE IN THIS AREA DO NOT WRITE IN THIS AREA DO NOT WRITE IN THIS AREA

EXTRA SPACE

If you use this extra page, you **MUST** write the question number clearly in the box provided.

Question No.

.....

.....

.....

.....

.....

.....

.....

.....

.....

.....

.....

.....

.....

.....

.....

.....

.....

.....

.....

.....

.....

.....

.....

.....

“*”Barcode Area*”
Sequential Bar Code

DO NOT WRITE IN THIS AREA

02138032/SPEC/K/MS/JUNE 2017

C A R I B B E A N E X A M I N A T I O N S C O U N C I L

CARIBBEAN ADVANCED PROFICIENCY EXAMINATION®

SPECIMEN

PHYSICS

UNIT 1 - PAPER 032

KEY AND MARK SCHEME

MAY/JUNE 2017

PHYSICS
UNIT 1 – PAPER 032
MARK SCHEME

Question 1

	KC	UK	XS
(a) Results of Experiment:			
Measured values to a consistent number of decimal places (1)			1
Calculated values to a consistent number of significant figures (1)		1	
			[2 marks]
(b) Graph of lg T vs lg m:			
Suitable scales (2)			
Labelled axes (quantity and unit)(1)			
5-6 correct points (3)			
3-4 correct points (Award 2 marks only)			
1-2 correct points (Award 1 mark only)			
Best-fit straight line(1)			
			[7 marks]
(c) Analysis			
(i) b = gradient of line			
large gradient triangle (1)			
correct read off of points (1)			
correct calculated value (approx. 0.5) (1)		1	2
			[3 marks]
(ii) lg a = y-intercept (1)			
correct calculation of a (1)			
			[2 marks]
(d) Correct statement of equation with values of a and b (1)			1
Total 15 marks		5	10

PHYSICS
UNIT 1 – PAPER 032
MARK SCHEME

Question 2

(a) Plotting of graph:

- Suitable scales (2)
- Labelled axes (quantity and unit)(1)
- 5-6 correct points (3)
- 3-4 correct points (Award 2 marks only)
- 1-2 correct points (Award 1 mark only)
- Best-fit line (2)

[7 marks]

(b) Calculation of gradient:

- large gradient triangle (1)
- correct read off of points (2)
- correct calculated value (approx. 0.5) (1)

Calculation of cross-sectional area

- Correct formula (1)
- Calculation with units (1)

Calculation of E

- Correct formula(1)
- Calculation with units(1)

[8 marks]

Total 15 marks

KC	UK	XS
		7
		3
	1	
		4
	5	10

PHYSICS
UNIT 1 – PAPER 032
MARK SCHEME

Question 3

	KC	UK	XS
(a) Identification of variables Identifies light intensity of source (1), distance from source to sample (1) and distance from sample to detector (1) as variables. [3 marks]			3
(b) Setup of apparatus Accurate labels (1) Correct placement of essential apparatus (2) Award 1 mark only if one piece of apparatus incorrectly placed. [3 marks]			3
(c) Procedure <ul style="list-style-type: none">Excludes other light sources (1)Keeps distance from source to sample constant (1)Keeps intensity from source constant by monitoring with a light meter (1)Measures intensity of source with light intensity meter (1) [4 marks]			4
(d) Results Plot results (1) should show a decrease in light intensity with thickness (1). No direct proportional variation between light intensity and thickness (1). [3 marks]			3
(e) Conclusion Valid conclusion drawn from results (1). Results following the inverse square law (1). [2 marks]			2
Total 15 marks			15



CANDIDATE – PLEASE NOTE!

PRINT your name on the line below and return this booklet with your answer sheet. Failure to do so may result in disqualification.

TEST CODE **02238010**

SPEC 2017/02238010

**CARIBBEAN EXAMINATIONS COUNCIL
CARIBBEAN ADVANCED PROFICIENCY EXAMINATION®**

PHYSICS

Unit 2 – Paper 01

1 hour 30 minutes



READ THE FOLLOWING INSTRUCTIONS CAREFULLY.

1. This test consists of 45 items. You will have 1 hour and 30 minutes to answer them.
2. In addition to this test booklet, you should have an answer sheet.
3. Do not be concerned that the answer sheet provides spaces for more answers than there are items in this test.
4. Each item in this test has four suggested answers lettered (A), (B), (C), (D). Read each item you are about to answer and decide which choice is best.
5. On your answer sheet, find the number which corresponds to your item and shade the space having the same letter as the answer you have chosen. Look at the sample item below.

Sample Item

Kirchoff's first law for electric currents can be derived by using the conservation of

- (A) energy
- (B) current
- (C) charge
- (D) power

Sample Answer



The correct answer to this item is “charge”, so (C) has been shaded.

6. If you want to change your answer, erase it completely before you fill in your new choice.
7. When you are told to begin, turn the page and work as quickly and as carefully as you can. If you cannot answer an item, go on to the next one. You may return to that item later.
8. You may do any rough work in this booklet.
9. Figures are not necessarily drawn to scale.
10. You may use a silent, non-programmable calculator to answer items.

DO NOT TURN THIS PAGE UNTIL YOU ARE TOLD TO DO SO.

LIST OF PHYSICAL CONSTANTS

Speed of light in free space	c	=	$3.00 \times 10^8 \text{ m s}^{-1}$
Permeability of free space	μ_0	=	$4\pi \times 10^{-7} \text{ H m}^{-1}$
Permittivity of free space	ϵ_0	=	$8.85 \times 10^{-12} \text{ F m}^{-1}$
	$\frac{1}{4\pi\epsilon_0}$	=	$9.0 \times 10^9 \text{ m F}^{-1}$
Elementary charge	e	=	$1.60 \times 10^{-19} \text{ C}$
Planck's constant	h	=	$6.63 \times 10^{-34} \text{ J s}$
Unified atomic mass constant	u	=	$1.66 \times 10^{-27} \text{ kg (931 MeV)}$
Rest mass of electron	m_e	=	$9.11 \times 10^{-31} \text{ kg}$
Rest mass of proton	m_p	=	$1.67 \times 10^{-27} \text{ kg}$
Acceleration due to gravity	g	=	9.81 m s^{-2}
1 Atmosphere	atm	=	$1.00 \times 10^5 \text{ N m}^{-2}$
Avogadro's number	N_A	=	$6.02 \times 10^{23} \text{ per mole}$

1. A 3V battery causes a current of 0.5 A to flow along a wire for 4 seconds. What is the quantity of charge that passes in this time?

- (A) 0.125 C
- (B) 1.5 C
- (C) 2 C
- (D) 6 C

2. Energy per unit of charge is a measure of

- (A) power
- (B) capacitance
- (C) electric field strength
- (D) potential difference

3. A current of 0.25 A flows in a uniform wire of length 2 metres and cross-sectional area $2 \times 10^{-9} \text{ m}^2$, when the potential difference across the wire is 4.25 V. What is the resistivity of the material from which the wire is made?

- (A) $5.9 \times 10^{-11} \Omega\text{m}$
- (B) $4.25 \times 10^{-9} \Omega\text{m}$
- (C) $1.7 \times 10^{-8} \Omega\text{m}$
- (D) $3.4 \times 10^{-8} \Omega\text{m}$

Item 4 refers to the following diagram which shows an arrangement of electrical components in a circuit.

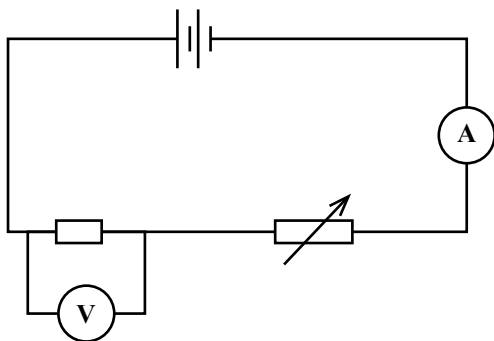

4. The variable resistor is adjusted to provide a smaller resistance. Which changes BEST describe the changes in the ammeter and voltmeter readings?

	Ammeter Reading	Voltmeter Reading
(A)	decrease	increase
(B)	decrease	decrease
(C)	increase	increase
(D)	increase	decrease

5. The cell in the following diagram has an e.m.f of 9.0V. The reading on the high resistance voltmeter is 5.0V.

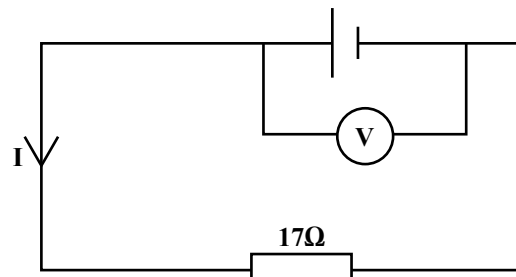

What is the current I?

- (A) $\frac{14}{17} \text{ A}$
- (B) $\frac{9}{17} \text{ A}$
- (C) $\frac{5}{17} \text{ A}$
- (D) $\frac{4}{17} \text{ A}$

6. A 3V battery of negligible internal resistance is connected to six identical resistors as shown in the diagram below.

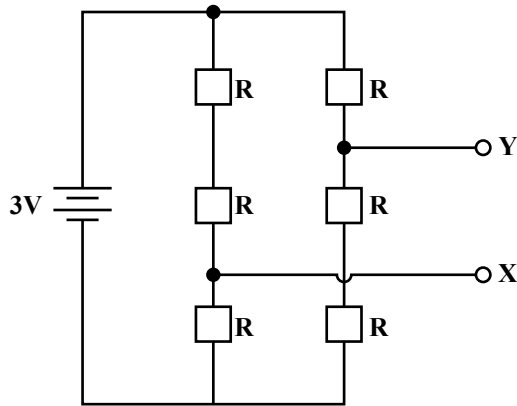

What is the potential difference between X and Y?

- (A) 1.0V
 (B) 1.5V
 (C) 2.0V
 (D) 3.0V
7. In a closed circuit or loop, the algebraic sum of the e.m.f. is equal to the algebraic sum of the products of current and resistance.

Which of the following statements is correct?

- (A) This is Kirchhoff's first law which is a consequence of conservation of energy.
 (B) This is Kirchhoff's first law which is a consequence of conservation of charge.
 (C) This is Kirchhoff's second law which is a consequence of conservation of energy.
 (D) This is Kirchhoff's second law which is a consequence of conservation of charge.

Item 8 refers to the following diagram which shows a positive point charge in free space. The distances from the charge to points X and Y are shown.

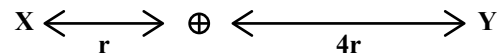

8. What is the ratio of the electric field strength at X, to the field strength at Y?

- (A) 1:4
 (B) 4:1
 (C) 16:1
 (D) 1:16

9. The force per unit charge on a positive test charge placed at a point in a field is called

- (A) electric energy
 (B) electric potential
 (C) dielectric constant
 (D) electric field strength

Item 10 refers to the following diagram

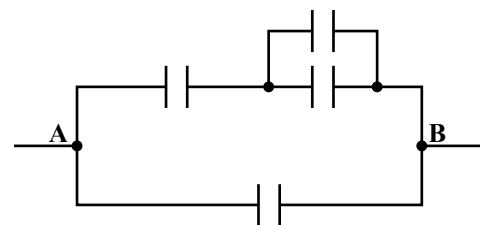

10. Each capacitor in the diagram above has capacitance C . What is the effective capacitance between A and B?

- (A) $\frac{3C}{5}$
 (B) $\frac{C}{4}$
 (C) $\frac{5C}{3}$
 (D) $4C$

GO ON TO THE NEXT PAGE

Item 11 refers to the following diagram.

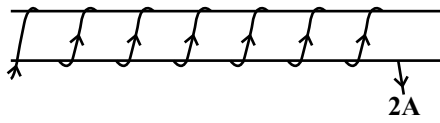

11. A hollow solenoid has 100 turns in a length of 0.5 m. If a steady current of 2A flows in the solenoid as shown in the diagram, what is the magnitude and direction of the flux density in the middle?

- (A) 1.3×10^{-4} T to the left
- (B) 5.0×10^{-4} T to the left
- (C) 1.3×10^{-4} T to the right
- (D) 5.0×10^{-4} T to the right

12. A wire of length 0.5 m and resistance 5Ω moves vertically with a velocity of 10 m s^{-1} perpendicular to a uniform magnetic field of flux density 4.0×10^{-5} T. What is the magnitude of the e.m.f. generated between the ends of the wire?

- (A) 1.0×10^{-4} V
- (B) 2.0×10^{-4} V
- (C) 4.0×10^{-4} V
- (D) 8.0×10^{-4} V

13. An electron beam moving with speed v enters a uniform magnetic field B , acting down the page as shown.

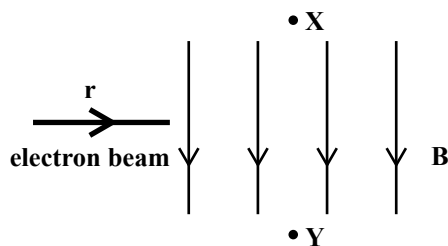

The beam of electrons will bend

- (A) out of the paper
- (B) into the paper
- (C) towards X
- (D) towards Y

14. Which diagram correctly shows the direction of the forces acting on adjacent current carrying conductors?

- (A) $\otimes \rightarrow \leftarrow \odot$
- (B) $\otimes \rightarrow \odot \rightarrow$
- (C) $\leftarrow \otimes \leftarrow \odot$
- (D) $\otimes \quad \odot \rightarrow$

15. The following diagrams illustrate a demonstration of Lenz's law of electromagnetic induction. In which diagram is the current in the correct direction?

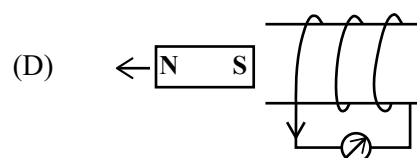
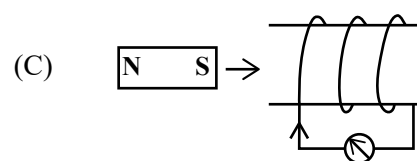
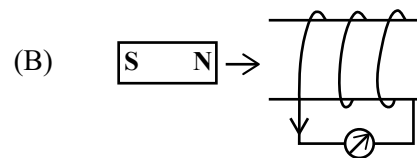
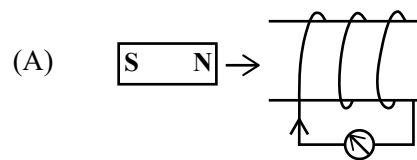

16. A sinusoidal alternating current of a peak value 20A dissipates power of 50W in a resistor R. The value of the resistor is

- (A) 0.03 Ω
- (B) 0.06 Ω
- (C) 0.13 Ω
- (D) 0.25 Ω

17. Which of the following graphs BEST represent the I -V characteristics of a silicon p - n unction diode?

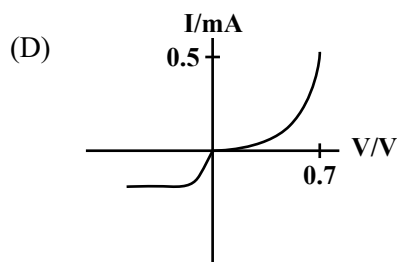
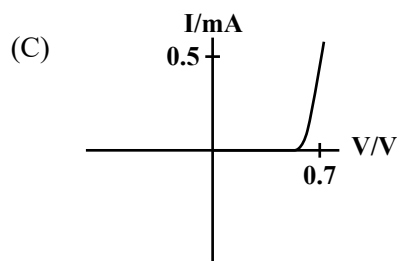
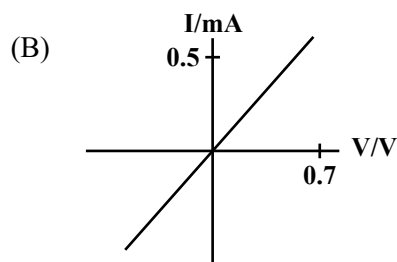
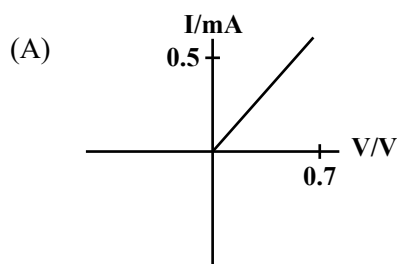

18. A direct current of 5A dissipates heat in a given resistor at the same rate as a sinusoidal alternating current flowing through the same resistor. What is the root mean square value of the alternating current?

- (A) $\sqrt{2}A$
- (B) 5A
- (C) $\sqrt[5]{2}A$
- (D) $\frac{5}{\sqrt{2}}A$

19. The ratio of the secondary turns to the primary turns in an ideal transformer is 1:30. A 120V a.c. supply is connected to the primary coil and a load of 20 Ω connected to the secondary coil. What is the secondary current?

- (A) 180 A
- (B) 6 A
- (C) 1.5 A
- (D) 0.2 A

Item 20 refers to the following diagrams.

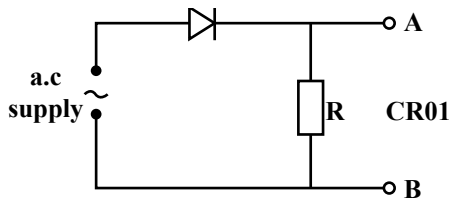

Figure 1

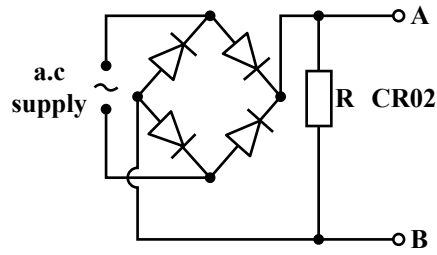
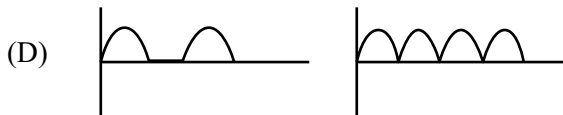
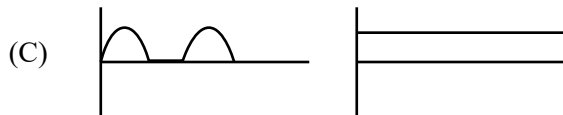
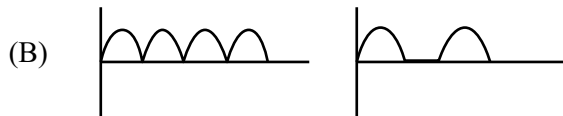
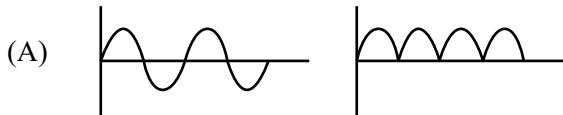
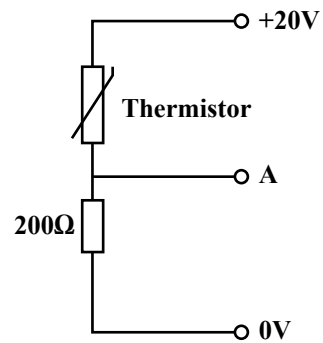

Figure 2

20. Which of the following traces will be seen on the cathode ray oscilloscopes in Figure 1 and Figure 2?



Item 21 refers to the following diagram.



21. The potential divider above is formed from a thermistor and a $200\ \Omega$ resistor.

The thermistor has a resistance of $2\ \text{k}\Omega$ at room temperature and $200\ \Omega$ at $100\ ^\circ\text{C}$.

What is the change in the potential at A when the thermistor is moved from water at room temperature to boiling water?

- (A) Rise of about 8V
- (B) Fall of about 8V
- (C) Rise of about 18V
- (D) Fall of about 18V

22. Which pair of values gives the open-loop gain of an ideal op. amp. and that of a typical op. amp?

	Ideal	Typical
(A)	0	100
(B)	∞	100000
(C)	100000	∞
(D)	0	100000

Item 23 refers to the following table.

X	Y	Z
0	0	1
0	1	1
1	0	0
1	1	1

23. Which of the following combinations gives the truth table shown above?

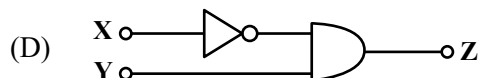
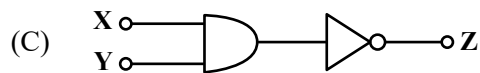
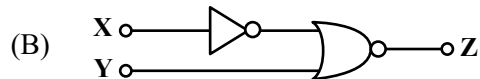
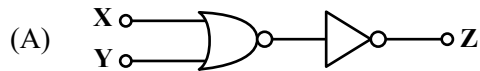

Item 24 refers to the following diagram which shows a non-inverting amplifier with negative feedback.

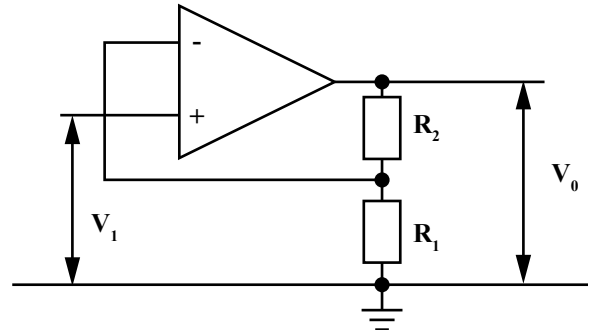

24. Which of the following represents the gain of the amplifier?

(A) $1 + \frac{R_2}{R_1}$

(B) $-\frac{R_2}{R_1}$

(C) $\frac{R_1}{R_1 + R_2}$

(D) $1 + \frac{R_1}{R_2}$

Item 25 refers to the following diagram

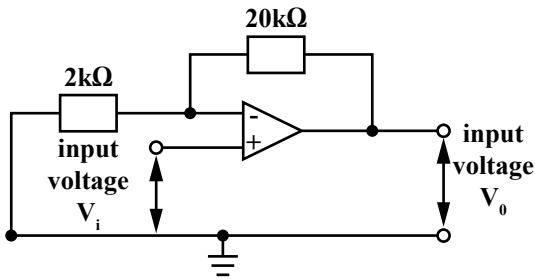

25. The gain of the op-amp in the diagram above is

- (A) -10
- (B) -9
- (C) 10
- (D) 11

Item 26 refers to the following diagrams.

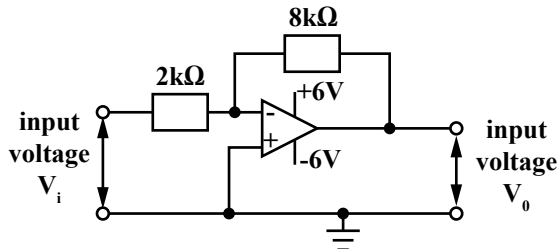

Figure 1

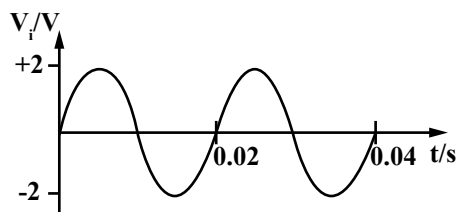
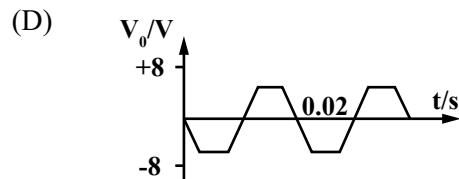
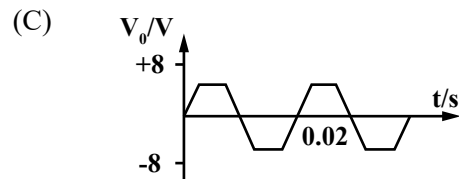
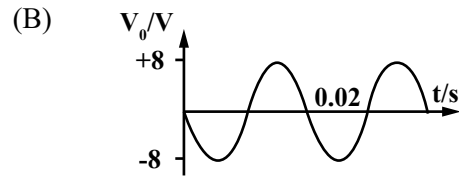
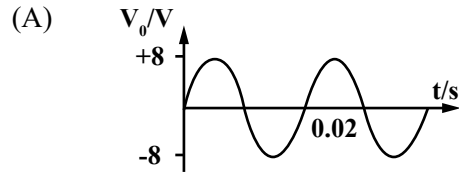
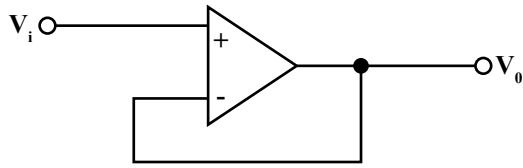

Figure 2

26. The sinusoidal alternating voltage shown in Figure 2 is applied to the input of the op-amp shown in Figure 1. The voltage of the power supply is +6V. Which one of the following graphs correctly shows the output voltage with time?



Item 27 refers to the following diagram.



27. Which of the following statements does NOT apply to the op-amp in the diagram above?

The op-amp circuit

- (A) is called a voltage follower
- (B) is used as an inverter
- (C) is used as a buffer
- (D) has a gain of one

Item 28 refers to the following diagram.

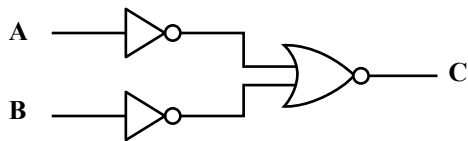

28. Which of the following gates is equivalent to the combination above?

- (A) OR
- (B) EXOR
- (C) AND
- (D) NAND

Item 29 refers to the following diagram of a half-adder.

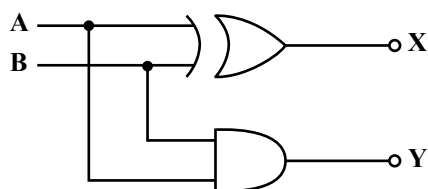

29. If $A = 1$ and $B = 0$, what are the values of the outputs X and Y?

- (A) $X = 0, Y = 0$
- (B) $X = 1, Y = 1$
- (C) $X = 1, Y = 0$
- (D) $X = 0, Y = 1$

30. Which of the following statements about R-S flip-flops are correct?

- I. It contains 2 cross-linked NAND or NOR gates
- II. The output is unpredictable for one combination of inputs.
- III. It has 2 input and one stable output state

- (A) I and II only
- (B) I and III only
- (C) II and III only
- (D) I, II and III

31. Which of the following phenomena BOTH demonstrate the wave nature of matter?

- (A) Reflection and Refraction
- (B) Interference and Diffraction
- (C) Line spectra and Interference
- (D) Polarisation and Photoelectric effect

32. In which of the following radiations do the photons have the LEAST energy?

- (A) x-rays
- (B) ultra violet
- (C) γ -rays
- (D) infrared

33. Photoelectrons are emitted from the surface of zinc metal when light of intensity, I , and wavelength, λ , is incident on it. What is the effect on the work function of the zinc metal if the intensity is doubled and the wavelength is reduced to $\frac{1}{4}$ of its previous value?

The work function is

- (A) doubled
 - (B) halved
 - (C) quartered
 - (D) unchanged
34. E.M. radiation is produced when very high speed electrons strike a hard target. This type of electromagnetic radiation is known as
- (A) U.V
 - (B) x-rays
 - (C) γ -rays
 - (D) microwaves
35. Which of the following graphs correctly show the relationship between the energy, E , of photons of light and their wavelength?

Item 36 refers to the following diagram

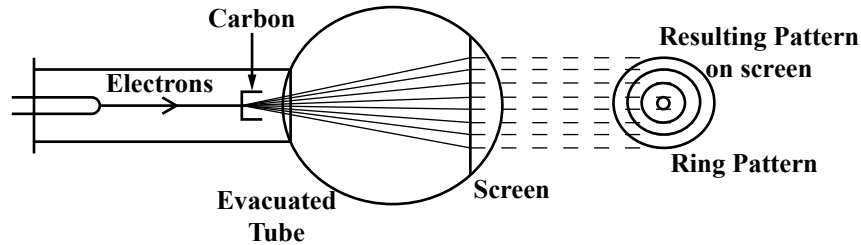

36. A beam of electrons is made to strike a thin layer of carbon in an evacuated tube as shown in the diagram above.

This experiment provides evidence for

- (A) interference
- (B) polarisation
- (C) the particle nature of light
- (D) the wave nature of particle

37. An object of mass m has kinetic energy, E_k . Which of the following is a correct expression for its de Broglie wavelength?

- (A) $\lambda = E_k / h$
- (B) $\lambda = h(2mE_k)^{\frac{1}{2}}$
- (C) $\lambda = \frac{h}{(2mE_k)^{\frac{1}{2}}}$
- (D) $\lambda = \frac{2h}{(mE_k)^{\frac{1}{2}}}$

38. An isotope of nickel is represented by ${}^{60}_{28}\text{Ni}$. Which line in the following table correctly describes a neutral atom of this isotope?

	Number of Neutrons	Number of Protons	Number of Electrons
(A)	32	28	32
(B)	32	28	28
(C)	60	32	28
(D)	28	32	28

Item 39 refers to the following diagram.

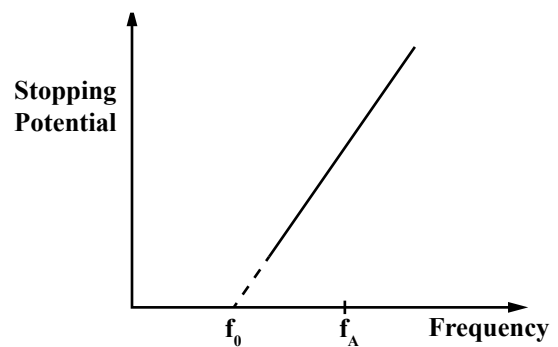

39. In an experiment to investigate photoelectricity, a graph of stopping potential of photoelectrons is plotted against frequency of incident radiation. What is the MAXIMUM kinetic energy of photoelectrons emitted by photons with frequency f_A ?
- (A) hf_0
(B) hf_A
(C) $hf_0 - hf_A$
(D) $hf_A - hf_0$
40. The mass of a nucleus is found to be 8.0032 u and that of its individual constituent nucleus is 8.0045 u. What is the binding energy of this nucleus?
- (A) 6.5×10^{22} J
(B) 1.9×10^{-13} J
(C) 6.9×10^{-16} J
(D) 2.4×10^{-47} J
41. The decay constant of a radioactive sample of radon gas is $1 \times 10^{-2} \text{ s}^{-1}$. If there were 1.6×10^5 atoms of radon gas present at a certain time, T, how much time must elapse before there is only 1.2×10^5 atoms of radon left?
- (A) 25s
(B) 29s
(C) 45s
(D) 400s
42. A nucleus of element A decays to mendelevium ${}_{101}^{255}\text{Md}$ by a sequence of three α particle emissions. How many neutrons are there in a nucleus of A?
- (A) 267
(B) 207
(C) 160
(D) 154
43. A radioactive substance emits a type of ionising radiation, P, with the following properties:
mass: zero
speed: $3 \times 10^8 \text{ m s}^{-1}$
- Which of the following statement(s) about P is/are true?
- I. P is not deflected by an electric field
II. P has a charge of equal to that of an electron
III. P maybe stopped by a piece of cardboard
- (A) I only
(B) II only
(C) I and II only
(D) II and III only
44. An archaeologist finds an ancient wooden relic and obtains its count rate as 20 counts per minute per gram of sample. The count rate obtained from the bark of a living tree is 104 counts per minute per gram and the background count rate is 8 counts per minute. What is the approximate age of the relic?
- [Radioactive carbon ${}^{14}_6\text{C}$ has a half-life of 5600 years]
- (A) 3000 years
(B) 11 000 years
(C) 17 000 years
(D) 22 000 years

GO ON TO THE NEXT PAGE

Item 45 refers to the following diagram which shows a Geiger-muller tube.

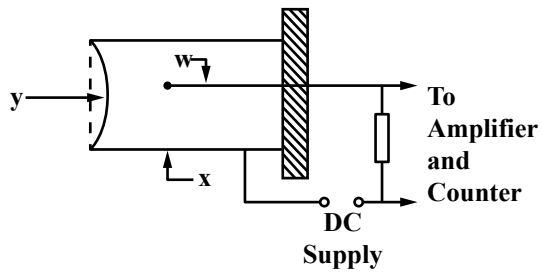

45. What are the parts labelled w, x and y?

	w	x	y
(A)	Cathode	Anode	Glass window
(B)	Anode	Cathode	Glass window
(C)	Cathode	Anode	Mica window
(D)	Anode	Cathode	Mica window

END OF TEST

IF YOU FINISH BEFORE TIME IS CALLED, CHECK YOUR WORK ON THIS TEST.

Master Data Sheet: Unit 2

Question	Module/Specific Objective	Profile	Key
1	1.1.1	UK	C
2	1.1.3	KC	D
3	1.1.5,1.1.7	UK	C
4	1.2.5	UK	C
5	1.1.5, 1.1.9,1.2.5	UK	C
6	1.2.5, 1.2.8	UK	A
7	1.2.6	KC	C
8	1.3.3	UK	C
9	1.3.6	KC	D
10	1.4.5	UK	C
11	1.5.3	UK	B
12	1.7.4	UK	B
13	1.6.4	UK	A
14	1.6.10	KC	D
15	1.7.5	UK	A
16	2.2.1	UK	D
17	2.1.4	KC	C
18	2.2.3	KC	B
19	2.2.5	UK	D
20	2.2.9	KC	D
21	2.3.1	UK	A
22	2.4.2	KC	B
23	2.5.4	UK	B
24	2.4.11	KC	A
25	2.4.14	UK	D
26	2.4.19	UK	D
27	2.4.19	KC	B
28	2.5.1	KC	C
29	2.5.6	KC	C
30	2.5.2	UK	A
31	3.1.20	KC	B
32	3.1.2	UK	D
33	3.1.6	KC	D
34	3.1.10	KC	B
35	3.1.2	KC	B
36	3.1.19	KC	D
37	3.1.21	UK	C
38	3.2.4	KC	B
39	3.1.7	UK	D
40	3.3.2	UK	B
41	3.4.8	UK	B
42	3.3.7	UK	A
43	3.4.4	KC	A
44	3.4.10	UK	C
45	3.4.11	KC	D

SPEC 2017/02238020



TEST CODE 02238020

MAY/JUNE 2017

CARIBBEAN EXAMINATIONS COUNCIL

CARIBBEAN ADVANCED PROFICIENCY EXAMINATION®

PHYSICS

UNIT 2 – Paper 02

2 hours 30 minutes

SPECIMEN PAPER

READ THE FOLLOWING INSTRUCTIONS CAREFULLY.

1. This paper consists of THREE questions. Answer ALL questions.
2. Write your answers in the spaces provided in this booklet.
3. Do NOT write in the margins.
4. Where appropriate, ALL WORKING MUST BE SHOWN in this booklet.
5. You may use a silent, non-programmable calculator to answer questions, but you should note that the use of an inappropriate number of figures in answers will be penalized.
6. If you need to rewrite any answer and there is not enough space to do so on the original page, you must use the extra lined page(s) provided at the back of this booklet. **Remember to draw a line through your original answer.**
7. **If you use the extra page(s) you MUST write the question number clearly in the box provided at the top of the extra page(s) and, where relevant, include the question part beside the answer.**

DO NOT TURN THIS PAGE UNTIL YOU ARE TOLD TO DO SO.

Copyright © 2017 Caribbean Examinations Council
All rights reserved.

02238020/CAPE/SPEC 2017

“*”Barcode Area”
Sequential Bar Code

NOTHING HAS BEEN OMITTED.

GO ON TO THE NEXT PAGE

02238020/CAPE/SPEC 2017

“*”Barcode Area*”
Sequential Bar Code

DO NOT WRITE IN THIS AREA

DO NOT WRITE IN THIS AREA

DO NOT WRITE IN THIS AREA

LIST OF PHYSICAL CONSTANTS

Speed of light in free space	c	=	$3.00 \times 10^8 \text{ m s}^{-1}$
Permeability of free space	μ_0	=	$4\pi \times 10^{-7} \text{ H m}^{-1}$
Permittivity of free space	ϵ_0	=	$8.85 \times 10^{-12} \text{ F m}^{-1}$
	$\frac{1}{4\pi \epsilon_0}$	=	$9.0 \times 10^9 \text{ m F}^{-1}$
Elementary charge	e	=	$1.60 \times 10^{-19} \text{ C}$
Planck's constant	h	=	$6.63 \times 10^{-34} \text{ J s}$
Unified atomic mass constant	u	=	$1.66 \times 10^{-27} \text{ kg (931 MeV)}$
Energy equivalence	u	=	$931 \text{ MeV}/c^2$
Rest mass of electron	m_e	=	$9.11 \times 10^{-31} \text{ kg}$
Rest mass of proton	m_p	=	$1.67 \times 10^{-27} \text{ kg}$
Acceleration due to gravity	g	=	9.81 m s^{-2}
1 Atmosphere	atm	=	$1.00 \times 10^5 \text{ N m}^{-2}$
Avogadro's constant	N_A	=	$6.02 \times 10^{23} \text{ per mole}$

GO ON TO THE NEXT PAGE

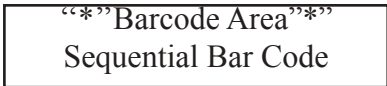

SECTION A

Answer ALL questions.

Write your answers in the spaces provided in this booklet.

1. The circuit shown in Figure 1 is used to study the discharge of a capacitor. When the moveable contact is connected to P, the capacitor, C, charges.

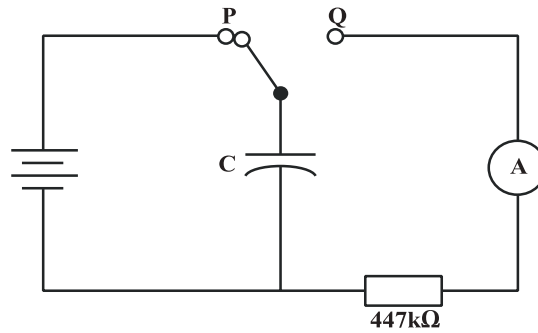

Figure 1. Circuit diagram

- (a) Explain how energy is stored in the capacitor when the switch is connected to P.

.....
.....
.....
.....

[2 marks]

- (b) When the switch is in position P, calculate the energy stored in the capacitor if the voltage, V, is 1.5 V and the value of the capacitor is 1 000 μF .

.....
.....
.....
.....
.....

[3 marks]

GO ON TO THE NEXT PAGE

- (c) In the space below, sketch the graph of the voltage across the capacitor versus time, from the time the switch reaches **P** until the capacitor fully charges.

[3 marks]

- (d) The switch is now moved to position **Q** and the capacitor discharges.

- (i) In the space below, sketch the graph of the voltage across the capacitor, V_c , versus time, from the time the switch reaches **Q** until the capacitor discharges.

[3 marks]

- (ii) Write the equation for the current during capacitor discharge.

.....
.....

[1 mark]

- (iii) The initial current I_0 was 100 mA. R is 47 K Ω and C is 1 000 μ F. Determine the time constant of the discharge in seconds.

.....
.....
.....
.....
.....
.....

[3 marks]

GO ON TO THE NEXT PAGE



(e) Describe the motion of the free electrons in a metallic conductor

- (i) before the current is switched on
- (ii) after the current is turned on.

.....

.....

.....

.....

[2 marks]

(f) Using your answers to (e) (i) and (e) (ii), explain the meaning of the term ‘drift velocity’.

.....

.....

[1 mark]

(g) Show that the drift velocity in a metallic conductor is given by $v = \frac{I}{neA}$ where n is the electron charge density, e is the electron charge, I is the current and A is the cross-sectional area of the conductor.

.....

.....

.....

.....

.....

.....

[3 marks]

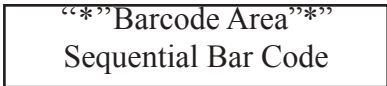

- (h) A length of Nichrome wire with cross-sectional area $2.60 \times 10^{-6} \text{ m}^2$ has a potential difference of 100 V across it. Nichrome has a resistivity of $5.0 \times 10^{-7} \Omega\text{m}$. The element dissipates thermal energy at a rate of 500 W.

Calculate

- (i) the current flowing through the wire

.....
.....

[2 marks]

- (ii) the resistance of the wire

.....
.....

[2 marks]

- (iii) the length of the wire

.....
.....
.....
.....

[3 marks]

- (i) Calculate the drift velocity of the electrons, given that each cubic metre of Nichrome contains 9.0×10^{28} conduction electrons.

.....
.....
.....
.....

[2 marks]

Total 30 marks

GO ON TO THE NEXT PAGE

2. The variation in the gain of an inverting amplifier at different frequencies may be investigated with the circuit shown in Figure 2. The input and output signals are displayed on the screen of a double beam cathode ray oscilloscope. A signal generator provides the input signal.

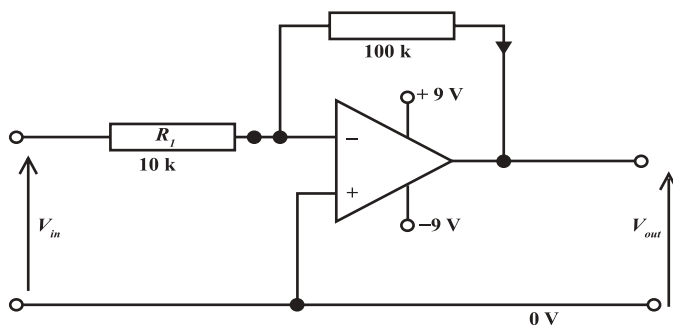

Figure 2. Circuit diagram

(a) What is the output of the amplifier when V_{in} is 0.5V?

.....
.....
.....
.....

[2 marks]

(b) The graph on page 12 shows the data collected in such an experiment.

(i) Use the graph to obtain a value of the gain A curves pointing to the following frequencies:

100 Hz, 1 000 Hz, 10 000 Hz, 32 000 Hz, 100 000 Hz.

Present your results in an appropriate table.

[4 marks]

GO ON TO THE NEXT PAGE

(ii) State what is meant by the bandwidth of an amplifier.

.....
.....
[1 mark]

(iii) Explain the use of logarithmic scales on the vertical and horizontal axes.

.....
.....
.....
.....
[2 marks]

(c) Draw tangents to the graph at the points ($\log_{10} f = 2.0$, $\log_{10} A = 2.0$) and ($\log_{10} f = 4.8$, $\log_{10} A = 1.54$) and produce them to find the point at which they intersect.

.....
.....
.....
.....
[3 marks]

(d) The point of intersection of the tangents gives the bandwidth of the amplifier.

(i) Determine the bandwidth of this amplifier.

.....
.....
[1 mark]

(ii) Calculate the resulting bandwidth of the amplifier if the input resistor was changed to 1 k Ω .

.....
.....
.....
.....
[2 marks]

GO ON TO THE NEXT PAGE

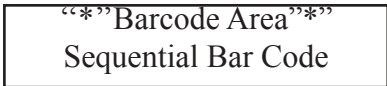

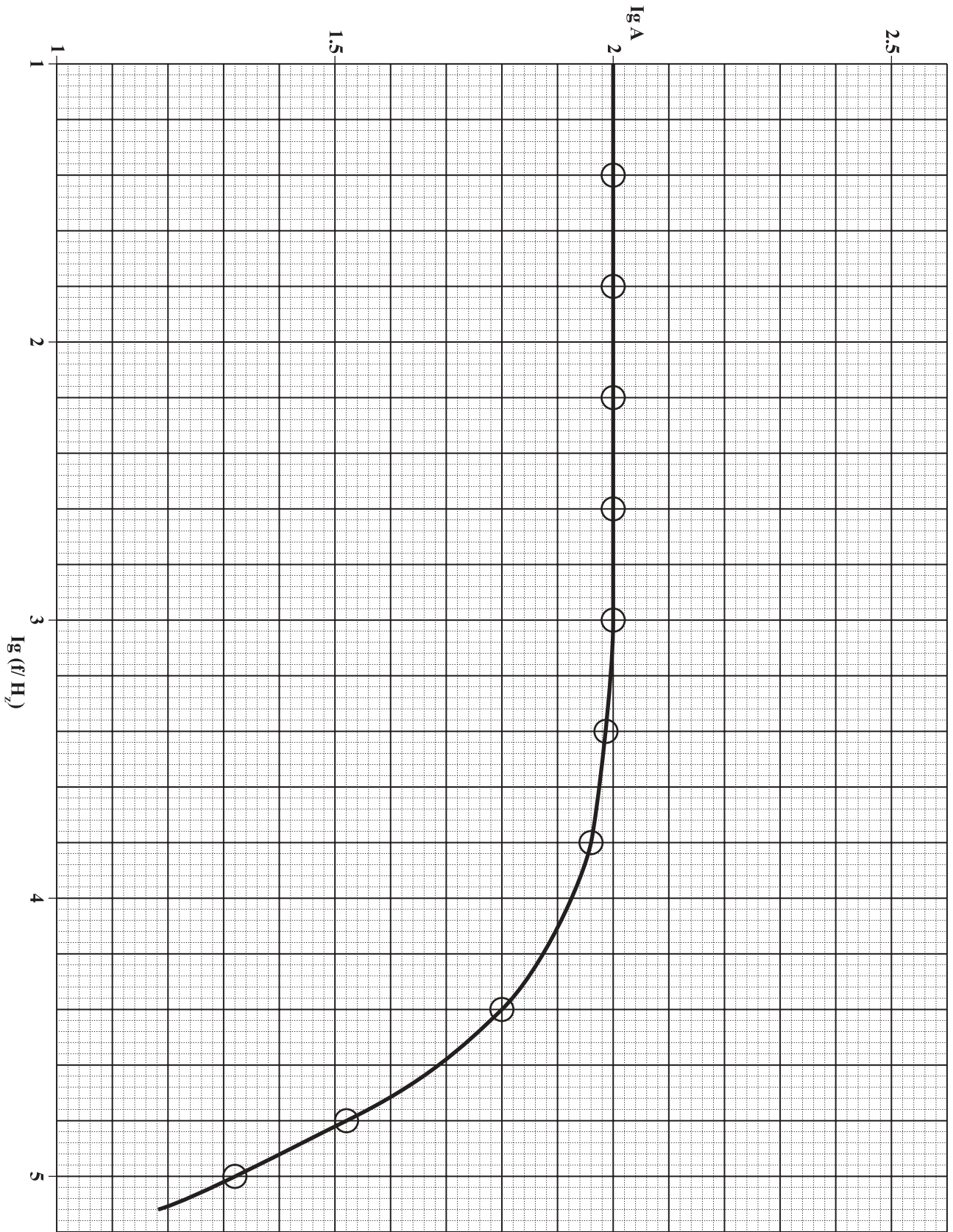

GO ON TO THE NEXT PAGE

02238020/CAPE/SPEC 2017

“*”Barcode Area*”
Sequential Bar Code

- (e) Figure 3 shows a logic circuit with TWO inputs, R and S, and TWO outputs Q and Q'.

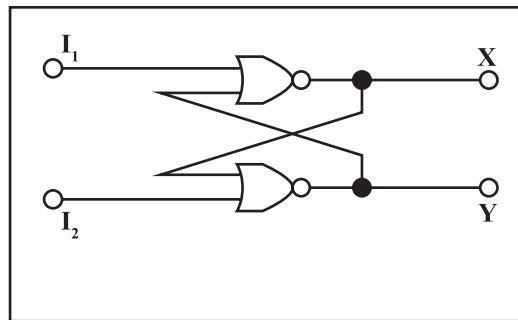

Figure 3

- (i) Name the type of circuit shown in Figure 3.

.....
.....

[1 mark]

- (ii) Name the logic gate used in the circuit.

.....
.....

[1 mark]

- (iii) Copy and complete the sequential truth table given in Table 1 to show the action of the circuit in Figure 3.

[2 marks]

Sequence	I_1	I_2	X	Y
1	0	1	1	0
2	0	0	1	0
3	1	0		
4	0	0		
5	0	1		
6	0	0		

GO ON TO THE NEXT PAGE

- (iv) By considering the role of feedback in the circuit and the condition for the type of gate in (e) (ii) to have a logic 0 output, explain why the output does NOT change when the input changes in the second step of the sequence (Row 2) as shown in Table 1.

.....
.....
.....
.....

[3 marks]

- (f) (i) Draw the circuit for a half-adder. Explain, with the aid of a truth table, what its function is and how it performs that function.

.....
.....
.....
.....
.....
.....
.....
.....
.....
.....
.....

[5 marks]

GO ON TO THE NEXT PAGE

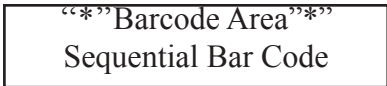

- (ii) TWO half-adders can be connected to form a full-adder as shown in Figure 4. This circuit has THREE inputs.

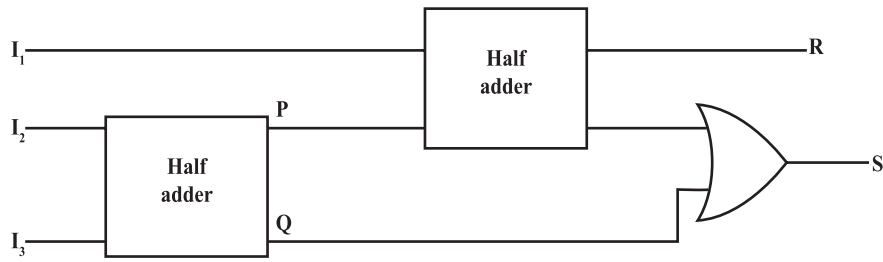

Figure 4.

Draw a table to show the outputs at points P, Q, R and S for the following input states:

- A. $I_1 = 1$ $I_2 = 0$ $I_3 = 1$
B. $I_1 = 1$ $I_2 = 1$ $I_3 = 1$

[2 marks]
Total 30 marks

GO ON TO THE NEXT PAGE

3. (a) (i) State what is meant by 'wave-particle duality'.

.....
.....
.....
.....

[2 marks]

(ii) Write the de-Broglie equation.

.....
.....

[1 mark]

(b) Sodium has a work function of 2.2 eV. Find

(i) its threshold wavelength

.....
.....
.....
.....

[2 marks]

(ii) the maximum energy of the photoelectrons when the metal is illuminated by light of wavelength $4 \times 10^{-7}\text{m}$

.....
.....
.....
.....

[2 marks]

GO ON TO THE NEXT PAGE

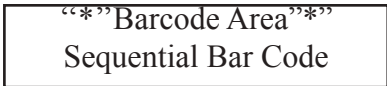

(iii) the stopping potential.

.....
.....

[1 mark]

(c) For the following equation, determine the energy released, in Joules.

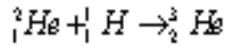

Mass of ${}^3_1\text{H} = 2.015 \mu$

Mass of ${}^1_1\text{H} = 1.008 \mu$

Mass of ${}^3_2\text{He} = 3.017 \mu$

.....
.....
.....
.....
.....
.....
.....

[4 marks]

(d) (i) Define the 'half-life' and 'decay constant' of a radioactive substance.

.....
.....
.....
.....

[2 marks]

GO ON TO THE NEXT PAGE

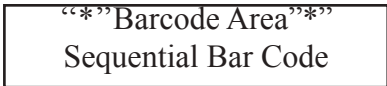

DO NOT WRITE IN THIS AREA

(ii) Radium has a half-life of 1.6×10^3 years. What is its decay constant?

.....
.....
.....
.....
.....
.....

[3 marks]

(iii) For a sample of 5.0×10^{16} radium nuclei at time zero, what is its activity?

.....
.....
.....
.....

[2 marks]

(iv) Write down the equation showing the decay of ${}_{88}^{226}\text{Ra}$ that produces both alpha and gamma decay.

.....
.....
.....
.....

[2 marks]

GO ON TO THE NEXT PAGE

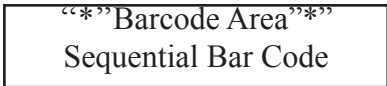

- (e) Another radioactive sample's activity was obtained for a 10-hour period.

Time/min	Activity/Cpm
60	3100
120	2450
240	1480
360	910
480	545
600	330

- (i) On the grid provided on page 20, display the above results on a graph to indicate an exponential decay.

GO ON TO THE NEXT PAGE

DO NOT WRITE IN THIS AREA

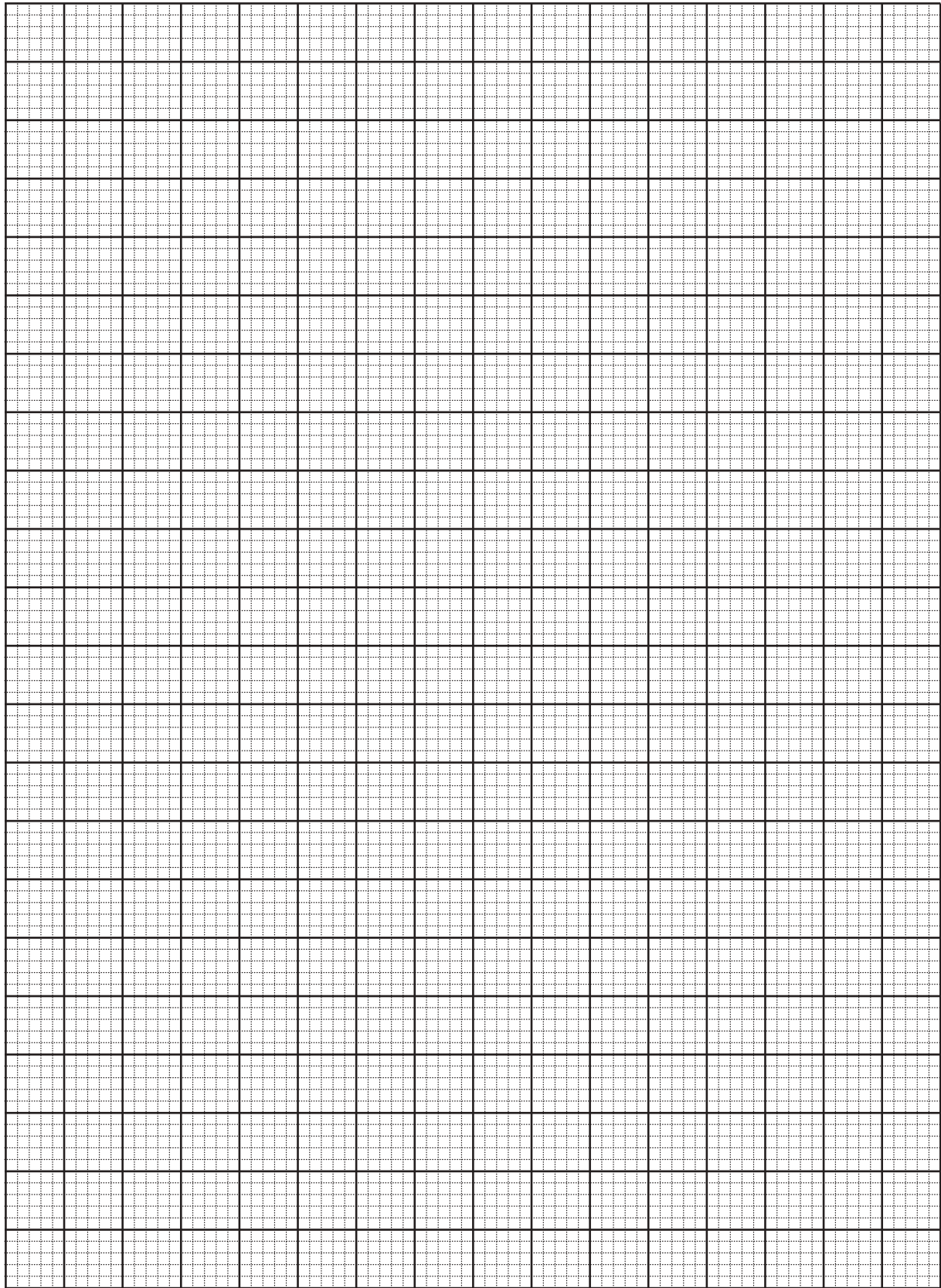

[5 marks]

GO ON TO THE NEXT PAGE

“*”Barcode Area”
Sequential Bar Code

(ii) Use your graph to determine the half-life of the sample.

.....
.....

[1 mark]

(iii) What will be the activity at time 900 minutes?

.....
.....
.....
.....
.....
.....

[3 marks]

Total 30 marks

EXTRA SPACE

If you use this extra page, you MUST write the question number clearly in the box provided.

Question No.

.....
.....
.....
.....
.....
.....
.....
.....
.....
.....
.....
.....
.....
.....
.....
.....
.....
.....
.....
.....
.....
.....
.....
.....
.....
.....

DO NOT WRITE IN THIS AREA

“*”Barcode Area”*
Sequential Bar Code

02238020/CAPE SPEC/MS/2017

C A R I B B E A N E X A M I N A T I O N S C O U N C I L

ADVANCED PROFICIENCY EXAMINATION

PHYSICS

UNIT 2 - PAPER 02

MARK SCHEME

2017

Question 1.

(a) The capacitor is connected to the power supply. An electric field is set up across the plates of the capacitor **(1)**. The plates become charged as electrons are attracted from the positive plates and simultaneously repelled from the negative terminal to the negative plate **(1)**

(b)

$$E = \frac{1}{2} CV^2 \quad (1)$$

$$= \frac{1}{2} \times 1000 \times 1.5^2 \quad (1)$$

$$= 1.13 \text{ m J} \quad (1)$$

(c)

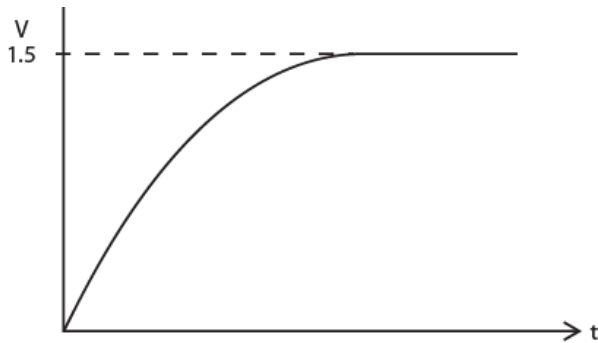

Shape **(2)**- Increasing portion **(1)**, saturation portion **(1)**
 Correctly labelled axes **(1)**

KC	UK	XS
2		
1	2	
	2	1

Question 1 continued

(d)
 (i)

KC	UK	XS
		1

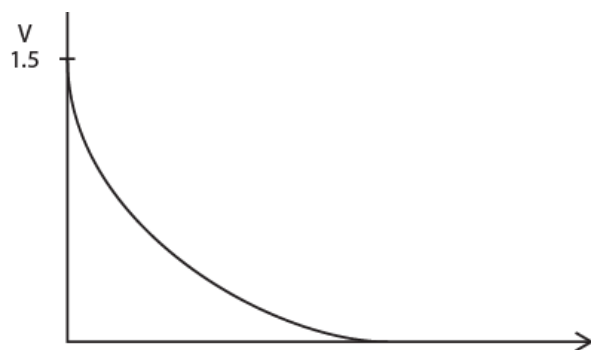
Question 1 continued

(ii)

Shape **(2)**- Increasing portion **(1)**, saturation portion **(1)**

(iii)

Correctly labelled axes **(1)**

$$I = I_0 (1 - e^{-t/CR}) \quad \mathbf{(1)}$$

(e)

(i)

$$T = C R \quad \mathbf{(1)}$$

$$= 1000 \times 10^{-6} \times 47 \times 10^3 = 47 \text{ sec}$$

(1)**(1)**

(ii)

(f)

Free electrons are in random motion before the current is switched on. Collisions between electrons are common **(1)**.After the current is switched on, electrons are guided by the electric field. They travel towards the positive potential **(1)**.The drift velocity is average velocity of particles as they are attracted to the positive potential. There are many collisions **(1)**.

(g)

Consider a segment of a conductor length L and cross-

KC	UK	XS
	2	
1		
1		
	2	
	2	
	1	
	1	
2		

Question 1 continued

sectional area A. The volume of the segment is $L \times A$.

- (h) The charge carriers travel at speed v
Then speed = dist/time $\Rightarrow V = L/t$
- (i) Number of charge carriers per unit volume = n
- (ii) The total charge in the segment is $enVtA$ **(1)**
The current flowing in charge passed/time
- (iii) i.e. $I = enVtA/t = enVA$ **(1)**
hence $V = I/neA$ **(1)**
- (i)

$$I = P/V \text{ (1)} = 500/100 = 5 \text{ A (1)}$$

$$R = \frac{V}{I} \text{ (1)} = \frac{100}{5} = 20\Omega \text{ (1)}$$

$$R = \frac{\rho L}{A} \text{ (1)}$$

$$L = \frac{RA}{\rho}$$

$$= \frac{20 \times 2.6 \times 10^{-6}}{5.0 \times 10^{-7}} \text{ (1)} = 104 \text{ m (1)}$$

$$V = \frac{I}{neA}$$

$$\text{Volume of conductor} = 104 \times 2.6 \times 10^{-6} = 2.704 \times 10^{-4} \text{ m}^3$$

$$n = 2.704 \times 10^{-4} \times 9.0 \times 10^{28}$$

$$= 2.43 \times 10^{25}$$

$$V = \frac{5}{2.43 \times 10^{25} \times 1.6 \times 10^{-19} \times 2.6 \times 10^{-6}} \text{ (1)}$$

$$= 0.49 \text{ ms}^{-1} \text{ (1)}$$

Total 30 marks

KC	UK	XS
	1	
1	1	
1	1	
1		
	2	
	2	
13	15	2

Question 2

(a)
$$\text{output} = \frac{V_2}{V_1} = - \frac{R_2}{R_1}$$

$$= - \frac{1\,000\,000}{10\,000} = -10 \quad (1)$$

- (b) When $V_1 = 0.5V$ then $V_2 = 5V \quad (1)$
 (i)

f (Hz)	Log ₁₀ f	Log ₁₀ A	A
100	2.0	2.00	100
1000	3.0	2.00	100
10,000	4.0	1.94	87.0
33,000	4.5	1.75	56.0
100,000	5.0	1.32	20.9

Columns 2 and 4 - all correct 2UK (-1 for each error)
 Column 3 - all correct 2XS (-1 for each error)

- (ii)

Band width = Range of operating frequencies for the amplifier (1) OR

- (iii) Range of frequencies for which the voltage gain does not fall below a specified fraction of the nominal gain (1)

Logarithmic scale more suitable for showing large range of frequencies encountered with op-amps (horizontal scale) (1)

Logarithmic scale more suitable for showing large range of gains encountered with op-amps OR

- (c) amplifiers widely used in audio applications and response of the ear is logarithmic hence logarithmic gain scale (vertical scales) (1)

- (d) Drawing two accurate tangents (2)
 (i) Read-off from intersection of tangents (1)

- (ii) At intersection $\log_{10}f \text{ BW} = 4.2$ hence $\text{BW} = \text{antilog}_{10}4.2 = 15.85 \text{ kHz} \quad (1)$

KC	UK	XS
	2	
		2
	2	
1		
		2
		3
	1	
		2

Question 2

If $R_1 = 1.0k$ gain becomes $-\frac{100}{1}$

(e) $= -100$

The gain increases to 100 or by a factor of 10 **(1)**.

Band width will be 1/10th as large since gain x BW is constant = 1.585 kHz **(1)**

(iii)

(i) R- S flip flop **(1)**

(ii) NOR gate **(1)**

(iv)

Sequence	R	S	Q	Q'
1	0	1	1	0
2	0	0	1	0
3	1	0	0	1
4	0	0	0	1
5	0	1	1	0
6	0	0	1	0

(f)

(i)

The circuit is an R-S FLIP-FLOP **(1)**. The present output is determined by the previous value of the outputs and the present values of inputs **(1)**. 0-0 on the input is compatible with any combination of outputs hence the output does not change when 0-0 is asserted at the input **(1)**.

The Half Adder

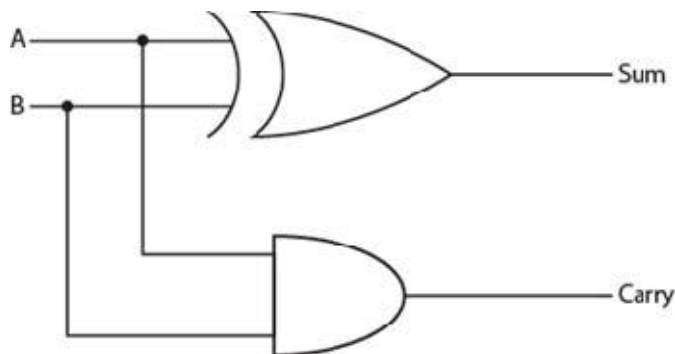

KC	UK	XS
1		
1	3	
	3	
2		
2		
1		

Question 2

(ii)

A	B	Sum	Carry
0	0	0	0
0	1	1	0
1	0	1	0
1	1	0	1

1 mark for Sum column, 1 mark for Carry column

When the result of binary addition produces a sum that cannot be accommodated by one column, the carry is necessary to report the result (1).

The Ex OR Gate produces the sum and the AND Gate produces the carry.

	I ₁	I ₂	I ₃	P	Q	R	S
A	1	0	1	1	0	0	1
B	1	1	1	0	1	1	1

Total 30 marks

KC	UK	XS
	2	
10	15	5

Question 3

(a) (i) A theory that seeks to explain the behaviour of light as waves **(1)** and in some cases as particles **(1)**.

$$(ii) \lambda = \frac{h}{P}$$

(b)
(i)

$$\Phi = 2.2 \text{ eV}$$

$$f_0 = \frac{W}{h} \text{ (1)} = \frac{2.2 \times 1.6 \times 10^{-19}}{6.63 \times 10^{-34} \text{ Js}} = 5.37 \times 10^{14} \text{ Hz (1)}$$

(ii)

KE max

$$E = hf + \Phi$$

$$E = \frac{hc}{\lambda} + \Phi \quad \text{(1)}$$

$$= \frac{6.63 \times 10^{-34} \times 3 \times 10^8 + 2.2 \times 10^{-19}}{4 \times 10^{-7}}$$

(iii)

$$= 7.17 \times 10^{-19} \text{ J (1)}$$

Stopping potential

$$\begin{aligned} eV_s &= hf - W \\ &= \frac{6.63 \times 10^{-34} \times 3 \times 10^8}{4 \times 10^{-7}} - 2.2 \times 10^{-19} \end{aligned}$$

$$eV_s = 4.12 \times 10^{-15}$$

$$V_s = \frac{4.12 \times 10^{-15}}{1.6 \times 10^{-19}} \text{ (1)}$$

KC	UK	XS
2		
1		
1	1	
1		
	1	
	1	

Question 3

(c) $E = \Delta mc^2$ (1)

$$\begin{aligned} \Delta m &= 3.017 \text{ u} - (2.015 \text{ u} + 1.008 \text{ u}) \\ &= -0.006 \text{ u} \quad (1) \\ &= 0.006 \times 1.66 \times 10^{-27} \\ &= 9.96 \times 10^{-30} \text{ kg} \quad (1) \\ E &= 9.96 \times 10^{-30} \times (3 \times 10^8)^2 \\ &= 8.97 \times 10^{-13} \text{ J} \quad (1) \end{aligned}$$

(d)

(i) Half-life is the time taken for half the number of particles to disintegrate (1).

Decay constant λ : is a characteristic of the atoms that decay such that

$$\lambda = -\frac{1}{N} \frac{dN}{dt} \quad (1)$$

(ii) $T_{\frac{1}{2}} = \frac{0.693}{\lambda}$ (1)

$$\lambda = \frac{0.693}{1.6 \times 10^3} \quad (1)$$

$$= 4.33 \times 10^{-4} \text{ s}^{-1} \quad (1)$$

(iii) $A = -\lambda N$ (1)

$$= -4.33 \times 10^{-4} \times 5 \times 10^{-4} \times 10^{16}$$

$$= 2.17 \times 10^{13} \text{ Bq} \quad (1)$$



KC	UK	XS
1		
	3	
2		
1		
	1	
	2	

Question 3

(e)

(i) For plotting graph

Suitable scales (1)

5-6 correct points (3)

3-4 correct points (Award 2 marks only)

1-2 correct points (Award 1 mark only)

<2 correct points (Award 0 marks)

Best fit line (1)

$$(ii) \text{ Half-life} = 144 \text{ min} \quad \therefore \lambda = \frac{0.693}{144 \times 60} \quad (1)$$

$$(iii) \begin{aligned} 900 \text{ min} &= \frac{900}{144} = 6.25 \text{ half-lives.} \\ T_{\frac{1}{2}} &= 174 \text{ min} \\ &= 174 \times 60 \text{ sec} \\ &= 10440 \text{ sec} \end{aligned} \quad (1)$$

$$\begin{aligned} \lambda &= \frac{0.693}{T_{\frac{1}{2}}} \\ &= \frac{0.693}{10440} \\ &= 6.6 \times 10^{-5} \end{aligned} \quad (1)$$

$$A = A_0 e^{-\lambda t}$$

$$\begin{aligned} \text{After 900 mins} & \text{ i.e. } 900 \times 60 \text{ sec} \\ &= 54000 \text{ sec} \\ &- 6.6 \times 10^{-5} \times 54000 \end{aligned}$$

$$\begin{aligned} \text{Activity} &= 3100 \times e \\ &= 3100 \times e^{-3.564} \\ &= 87.4 \text{ cpm} \end{aligned} \quad (1)$$

Total 30 marks

KC	UK	XS
		5
	1	
	3	
10	15	5

Graph for Question 3 (e) (i)

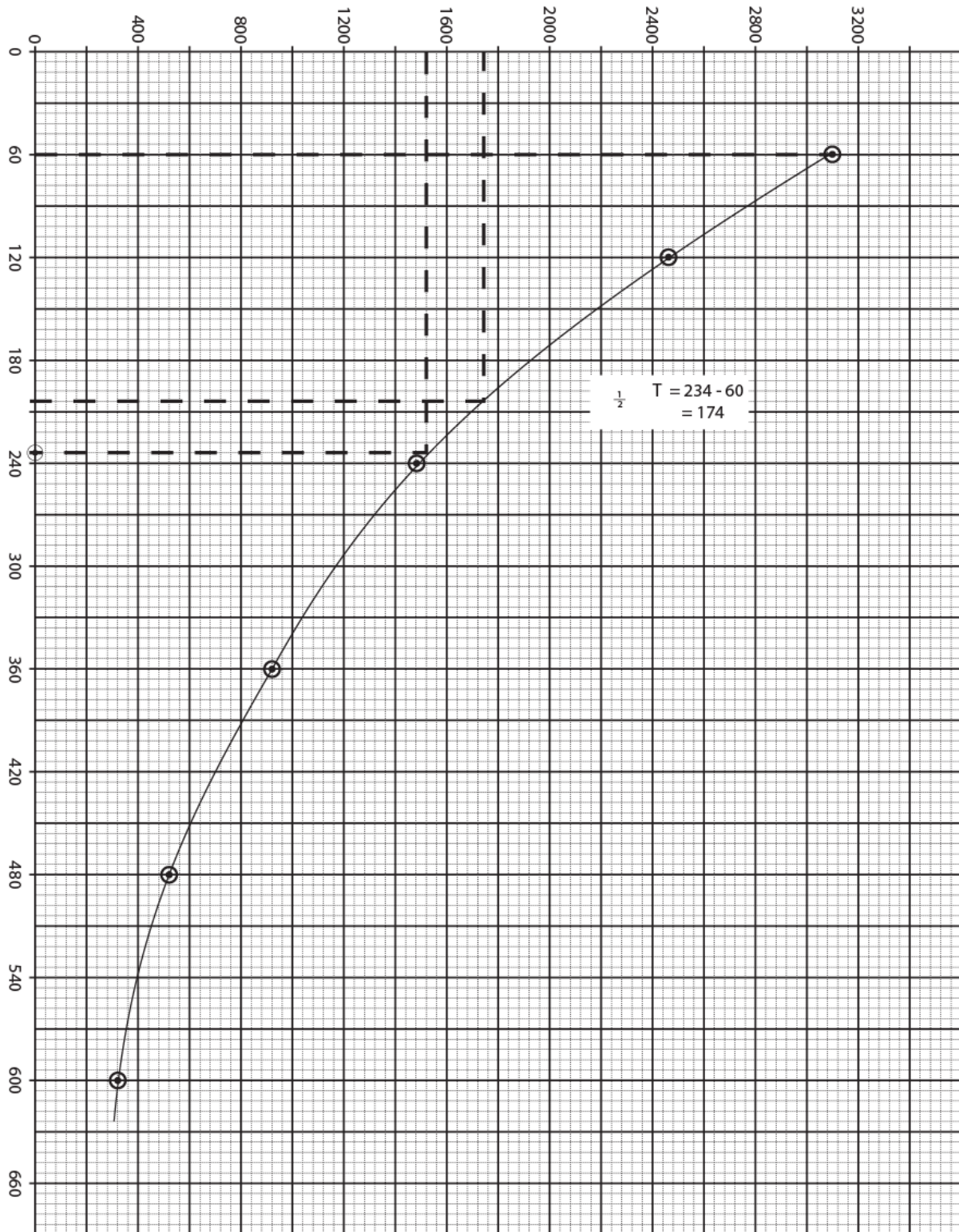



CARIBBEAN EXAMINATIONS COUNCIL

CARIBBEAN ADVANCED PROFICIENCY EXAMINATION®

PHYSICS

UNIT 2 – Paper 032

ALTERNATIVE TO SCHOOL-BASED ASSESSMENT

*2 hours***READ THE FOLLOWING INSTRUCTIONS CAREFULLY.**

1. This paper consists of THREE questions. Answer ALL questions.
2. Write your answers in the spaces provided in this booklet.
3. Do NOT write in the margins.
4. Where appropriate, ALL WORKING MUST BE SHOWN in this booklet.
5. You may use a silent, non-programmable calculator to answer questions, but you should note that the use of an inappropriate number of figures in answers will be penalized.
6. You are advised to take some time to read through the paper and plan your answers.
7. If you need to rewrite any answer and there is not enough space to do so on the original page, you must use the extra lined page(s) provided at the back of this booklet. **Remember to draw a line through your original answer.**
8. **If you use the extra page(s) you MUST write the question number clearly in the box provided at the top of the extra page(s) and, where relevant, include the question part beside the answer.**

DO NOT TURN THIS PAGE UNTIL YOU ARE TOLD TO DO SO.

Copyright © 2017 Caribbean Examinations Council
All rights reserved.

Answer ALL questions.

Write your answers in the spaces provided in this booklet.

1. (a) In this experiment, you will investigate the relationship between the peak-peak voltage of an alternating current waveform and its effective value in delivering power to a pure resistor.

You are provided with the following:

- 20 Ω , 100W wire wound resistor
- Calorimeter
- Mercury in glass thermometer (0 $^{\circ}$ C - 100 $^{\circ}$ C)
- Stirrer
- Large beaker containing approximately 1.5 litres water maintained at constant temperature (ambient temp of tap water will suffice)
- Digital scale
- Oscilloscope
- 0-30V variable output voltage ac power supply (5A)
- Timer
- Calibrated digital multimeter

Procedure

1. Weigh the empty calorimeter and record its weight in Table 1.
2. Pour approximately 200 mL of water into the calorimeter and weigh calorimeter and the added water. Record this result in Table 1.
3. Determine, m , the mass of added water by subtraction and record this value in Table 1.
4. Using a calibrated multimeter, measure the true resistance, R , of the nominal 25 Ω resistor and record this value in Table 1.
5. Set up the apparatus as shown in Figure 1.

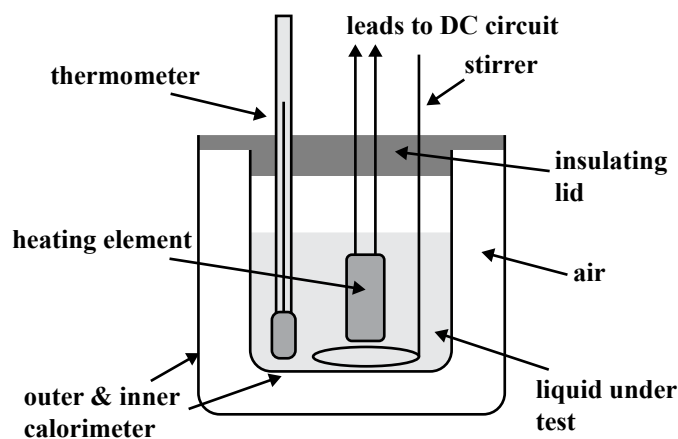

Figure 1. Diagram of apparatus

The heating element is the 20 Ω resistor and the leads will be connected to the AC supply (instead of DC as shown in the diagram).

GO ON TO THE NEXT PAGE

6. Using the oscilloscope, adjust the output of the ac supply to a peak voltage of 30V.
7. Switch off the ac supply and connect its output to the 20Ω resistance heating element.
8. Record the initial temperature, T_i , of the water as indicated by the thermometer
9. Switch on the ac supply and start the timer.
10. Stir the water as continuously as is convenient and after 15 minutes (time interval Δt) switch off the ac supply and record the temperature.
11. Wait for the apparatus to cool.
12. Repeat steps (1) – (10) for a fresh quantity of water (mass of added water, m , should be the same throughout the experiment) and ac supply of 25V, 20V, 15V and 10V peak voltages.

TABLE 1: RESULTS OF EXPERIMENT

Mass of calorimeter	
Mass of calorimeter + water	
Mass of added water, m	
Resistance of heating resistor, R	
Time interval, Δt	

[3 marks]

- (b) Using a suitable table, record the remainder of the results of the experiment in the space provided below.

[4 marks]

(c) On the grid provided on page 6, plot a graph of the temperature change, ΔT , vs $(V_{pk} / \text{sqrt}(2))^2$
[4 marks]

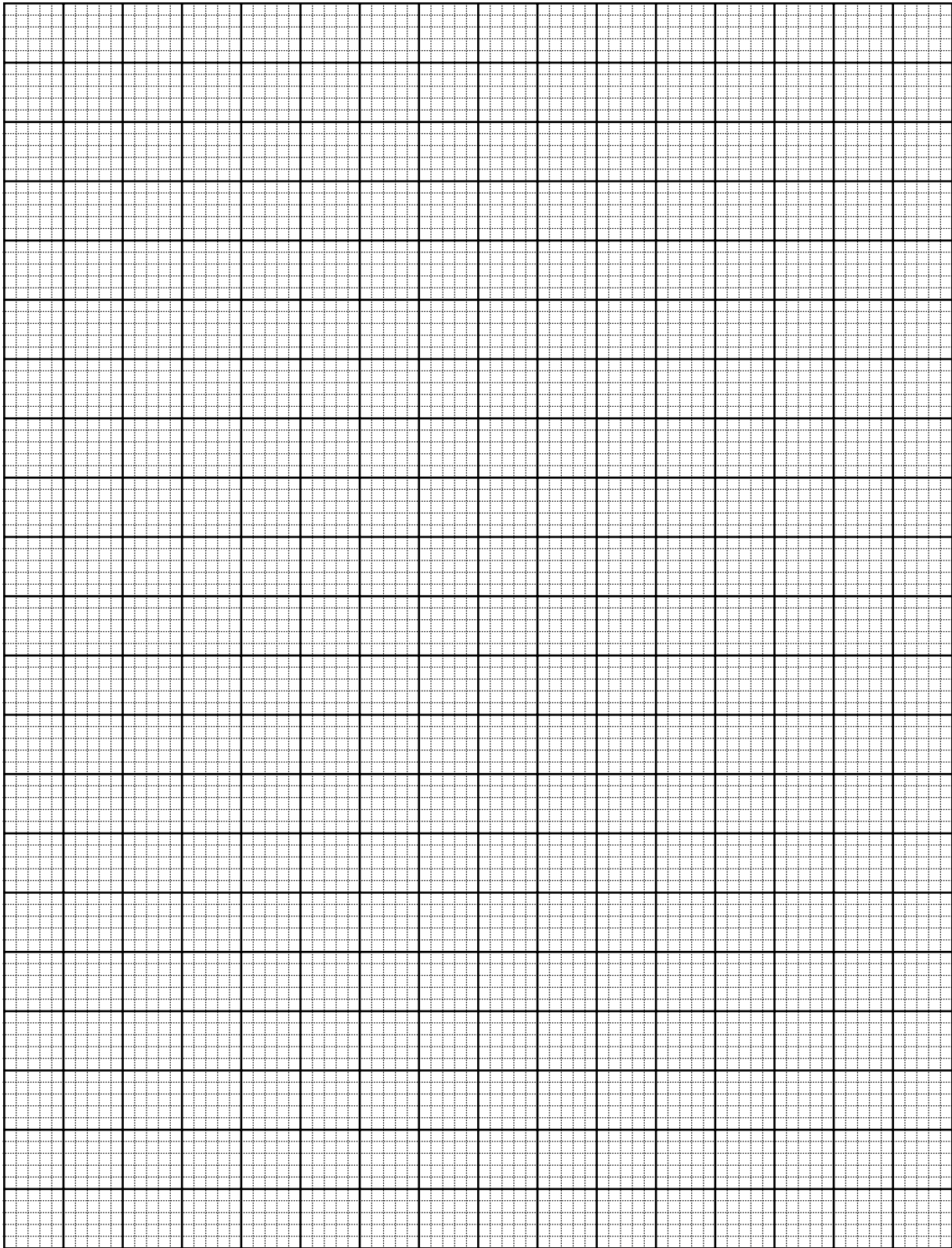

GO ON TO THE NEXT PAGE

DO NOT WRITE IN THIS AREA

(d) Determine the slope of your graph plotted in Part (c).

.....

.....

.....

.....

[2 marks]

(e) Compare the value obtained in Part (d) with the theoretical value, $S = \Delta t/mRC$, where C is the specific heat capacity of water. Comment on your result.

.....

.....

.....

.....

[2 marks]

Total 15 marks

2. The circuit in Figure 2 has been set up with a cell of e.m.f, E , and internal resistance, r .

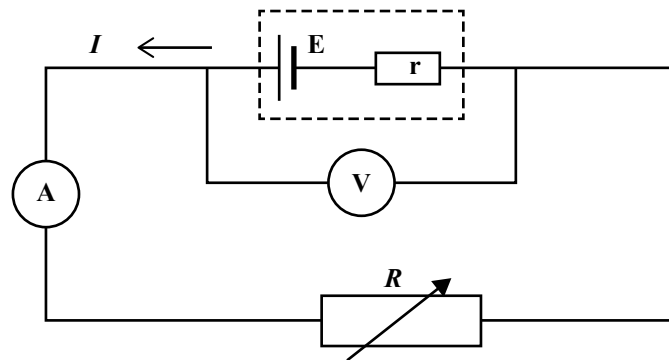

Figure 2. Circuit diagram

One equation that is relevant to the circuit is:

$$V = E - Ir$$

GO ON TO THE NEXT PAGE

- (a) Several values of R and I are measured and plotted on a graph of R against $\frac{1}{I}$, shown in Figure 3. The equation of the graph is $R = \frac{E}{I} - r$.

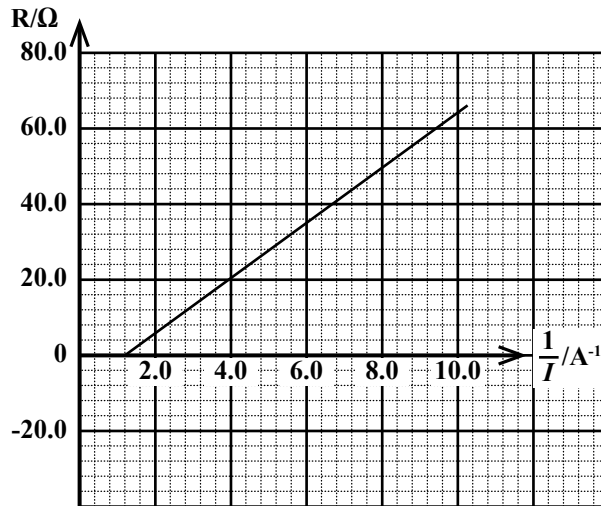

Figure 3. Graph of R against $\frac{1}{I}$

- (i) Use the graph in Figure 3 to find the internal resistance, r , of the cell.

.....
.....
.....

[1 mark]

- (ii) Determine the e.m.f of the cell.

.....
.....
.....
.....
.....

[2 marks]

GO ON TO THE NEXT PAGE

- (iii) Using values obtained from the graph in Figure 3, calculate the power dissipated in the resistor R , when there is a current of 0.25 A.

.....
.....
.....
.....
.....
.....
.....

[3 marks]

- (b) A second identical cell is added in series with the original cell and the experiment is repeated.

- (i) Determine the new e.m.f and internal resistance of the combined cells.

.....
.....
.....
.....

[2 marks]

- (ii) Given an e.m.f. of 8 V and an internal resistance of 3 Ω , complete Table 2 using the equation for R given in Part (a).

TABLE 2: RESULTS OF EXPERIMENT

I (A)	1/I (A^{-1})	R (Ω)
0.1		
0.2		
0.5		
0.8		
1.0		

[3 marks]

GO ON TO THE NEXT PAGE

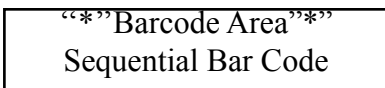

- (iii) On the grid provided on page 10, plot a graph of R against $\frac{1}{f}$, using the results of the experiment in Table 2. [4 marks]

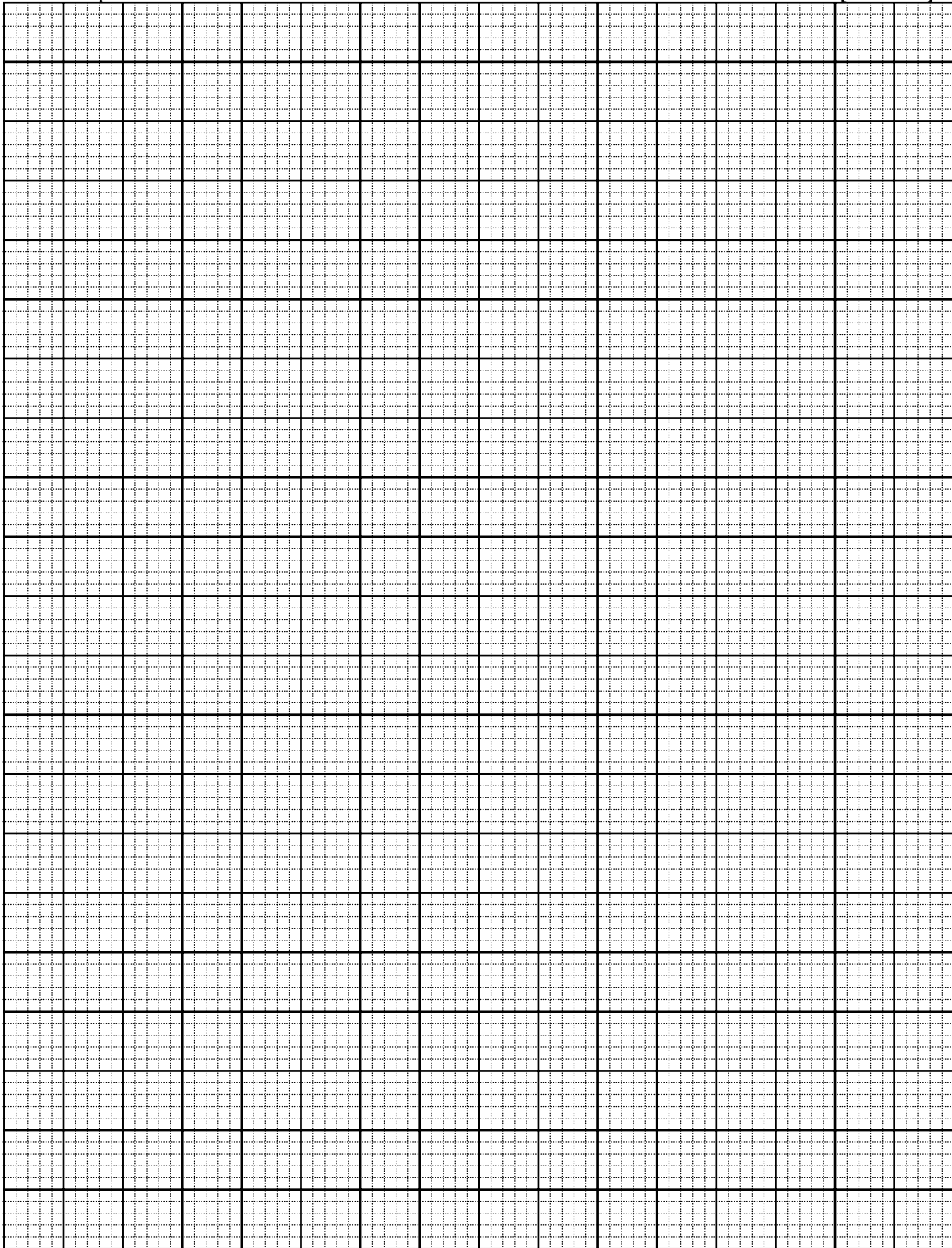

Total 15 marks

GO ON TO THE NEXT PAGE

3. A photocell generates electricity when it is exposed to light from the visible spectrum. The voltage produced in the photocell varies with the intensity of the light source. A student suggests that the voltage produced also varies with the colour of the light.

Assume that you are provided with the following apparatus

- Photocell
- Voltmeter
- Sheltered light intensity meter/photocell
- Selection of filters
- Light source of variable intensity
- Metre rule

Design an experiment to investigate the response of the photocell to the light of three different colours and the intensity of the light. Write your answers under the following headings.

- (a) Identification of variables

.....
.....
.....
.....

[2 marks]

- (b) Set-up of apparatus

.....
.....
.....
.....
.....
.....
.....

[3 marks]

GO ON TO THE NEXT PAGE

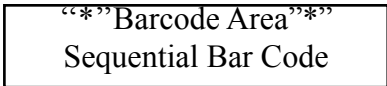

(c) Procedure

.....

.....

.....

.....

.....

.....

.....

.....

.....

.....

.....

[5 marks]

(d) Results and Conclusion

.....

.....

.....

.....

.....

.....

.....

.....

.....

.....

.....

[5 marks]

Total 15 marks

GO ON TO THE NEXT PAGE

DO NOT WRITE IN THIS AREA

02238032/SPEC/K/MS/JUNE 2017

C A R I B B E A N E X A M I N A T I O N S C O U N C I L

CARIBBEAN ADVANCED PROFICIENCY EXAMINATION®

SPECIMEN

PHYSICS

UNIT 2 - PAPER 032

KEY AND MARK SCHEME

MAY/JUNE 2017

PHYSICS
UNIT 2 – PAPER 032
MARK SCHEME

Question 1

(a) Table 1: Results of Experiment

Mass of calorimeter	0.62 kg
Mass of calorimeter + water	0.85 kg
Mass of added water, m	0.23 kg
Resistance of heating resistor, R	20.8Ω
Time interval, Δt	15 mins = 900s

2 XS for accurate recording of ALL results in Rows 1 - 4
(Deduct 1 XS if any row is incorrect.)

1 UK for accurate recording of result in Row 5.

[3 marks]

(b) Further results of experiment

V _{pk} (volts)	T _i	T _f	ΔT = T _f - T _i	(V _{pk} /√2)) ²
30	27.0	50.2	23.2	450
25	28.3	44.4	16.1	313
20	28.5	38.8	10.3	200
15	29.3	35.1	5.80	113
10	28.4	30.9	2.50	50.0

For Columns 1 -3, award 2 **XS** for sensible results and correct sig. figs

For Columns 4 and 5 calculations, award 2 **UK** for correct results, deduct 1 mark for each error

[4 marks]

(c) Plotting of Graph

- Suitable scales (1)
- Labelled axes (quantity and unit) (1)
- All points accurately plotted (1)
- Best-fit straight line (1)

[4 marks]

(d) Slope S, measured from graph = $\frac{21.9-0.0}{425-0.0} = 0.051 \text{ } ^\circ\text{C/Volt}$

- correct read off of points (1 **XS**)
- correct calculated value (1 **UK**)

[2 marks]

KC	UK	XS
	1	2
	2	2
		4
	1	1

PHYSICS
UNIT 2 – PAPER 032
MARK SCHEME

(e) Theoretical value of slope $S = \frac{900}{0.23 \times 20.8 \times 4180} = 0.045 \text{ } ^\circ\text{C/Volt}$
(1 UK)

CONCLUSION: Relationship verified within the limits of experimental error.

Cumulative experimental error substantial because of the large number of measurements. **(1 XS)**

[2 marks]

Total 15 marks

KC	UK	XS
	1	1
	5	10

PHYSICS
UNIT 2 – PAPER 032
MARK SCHEME

Question 2

		KC	UK	XS																		
(a) (i)	By extrapolation, 8Ω (1) [1 mark]			1																		
(ii)	Reading off values from graph (1 XS) Gradient, read off values and calculate, for example: $(64-0)/(10-1.2) = 7.2 \text{ V}$ (1 UK) [2 marks]		1	1																		
(iii)	$1/I = 4 \text{ A}$ $R = 20\Omega$ (1 XS) $P = I^2R$ or $P = IV$ or $P = V^2/R$ (after finding V using equation given) (1 UK) $P = (0.25)^2 \times 20 = 1.25 \text{ W}$ (1 UK) [3 marks]		2	1																		
(b) (i)	Both would double: $E = 14.4 \text{ V}$; $r = 16 \text{ V}$ (2) [2 marks]		2																			
(ii)	<table border="1" data-bbox="427 1022 1089 1211"> <thead> <tr> <th>I (A)</th> <th>1/I (A⁻¹)</th> <th>R (Ω)</th> </tr> </thead> <tbody> <tr> <td>0.1</td> <td>10</td> <td>77</td> </tr> <tr> <td>0.2</td> <td>5</td> <td>37</td> </tr> <tr> <td>0.5</td> <td>2</td> <td>13</td> </tr> <tr> <td>0.8</td> <td>1.25</td> <td>7</td> </tr> <tr> <td>1.0</td> <td>1</td> <td>5</td> </tr> </tbody> </table> 1/I column correctly calculated (1) R column correctly calculated (2) [3 marks]	I (A)	1/I (A ⁻¹)	R (Ω)	0.1	10	77	0.2	5	37	0.5	2	13	0.8	1.25	7	1.0	1	5			3
I (A)	1/I (A ⁻¹)	R (Ω)																				
0.1	10	77																				
0.2	5	37																				
0.5	2	13																				
0.8	1.25	7																				
1.0	1	5																				
(iii)	Plotting of graph 4 accurate points (2) 2-3 accurate points (1) <2 accurate points (0) Suitable scales (1) Accurate labeling (1) [4 marks]			4																		
Total 15 marks																						
			5	10																		

PHYSICS
UNIT 2 – PAPER 032
MARK SCHEME

Question 3

(a)

Part	Relationship Tested	Dependent Variable	Independent Variable	Controlled Variable	Expected Results
1	Voltage/intensity	voltage	intensity	colour	
2	Voltage/colour	voltage	colour	intensity	

1 mark for each correct row

[2 marks]

(b) Setup of apparatus

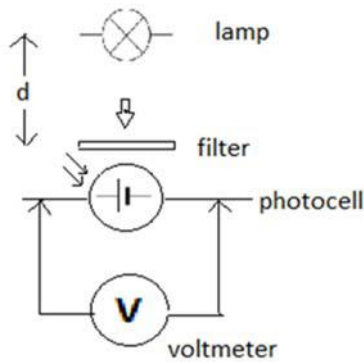

Proper arrangement as shown (1)

3-4 accurate labels (2)

1-2 accurate labels (1)

[3 marks]

KC	UK	XS
		2
		3

PHYSICS
UNIT 2 – PAPER 032
MARK SCHEME

Question 3 continued

(c) Procedure

(1) For Voltage/Intensity:

With no colour filters (or same colour filter) present **(1)**
vary the distance of lamp (d) from photocell OR change vary
lamp intensity for at least three positions **(1)**.

Measure and record voltage **(1)**

(2) For Voltage/Colour:

With distance (d) fixed **(1)**, measure and record the voltage
for at least 3 different colours **(1)**

[5 marks]

(d) Results and Conclusion

	Intensity	Voltage/V	Conclusion
1	low	V ₁	V depends on Intensity if $V_1 \neq V_2 \neq V_3$ (1)
	medium	V ₂	Inverse/proportional relationship (1)
	high	V ₃	V independent intensity if $V_1 = V_2 = V_3$ (1)
2	Colour 1	V ₁	V depends on colour if $V_1 \neq V_2 \neq V_3$ (1)
	Colour 2	V ₂	V independent colour if $V_1 = V_2 = V_3$ (1)
	Colour 3	V ₃	

Total 15 marks

KC	UK	XS
		5
		5
		15

CARIBBEAN EXAMINATIONS COUNCIL

**REPORT ON CANDIDATES' WORK IN THE
CARIBBEAN ADVANCED PROFICIENCY EXAMINATION**

MAY/JUNE 2004

PHYSICS

**Copyright © 2004 Caribbean Examinations Council
St Michael, Barbados
All rights reserved**

PHYSICS

CARIBBEAN ADVANCED PROFICIENCY EXAMINATION MAY/JUNE 2004

GENERAL COMMENTS

UNIT 1 & 2

The number of entries for Cape Physics in 2004 increased markedly over that for 2003: from 411 to 793 for Unit 1 and from 269 to 318 for Unit 2. Although the performances on Paper 01 in both units were similar in the two years that on Paper 02 was not. In both units the mean score on Paper 02 was around 28 out of ninety which is hardly satisfactory.

Some of the reasons identified for the poor performance on Paper 02 were:

- Candidates' inability to satisfactorily complete derivations of formulae specified in the syllabus.
- Poor reasoning skills resulting in confused written explanations of physical phenomena
- Whilst candidates could score marks in Paper 1 for selecting and substituting in the correct formula, Paper 02 required a higher level of problem solving skill. Where successful calculation of a quantity required two or more steps, many of the candidates could not even get started and therefore lost valuable credit.
- In the data analysis questions at the start of the paper candidates lacked the skills necessary to extract and apply information from graphs.

The development of the higher level skills outlined above takes time and experience. It is hoped that once teachers are aware of these deficiencies that curricula can be modified so that future CAPE candidates will have the opportunity to practise these and become more proficient and more confident.

DETAILED COMMENTS

UNIT 1

PAPER 01

Module 1

Question 1

The mean score on this straightforward Newton's law question was a low 3.1 marks out of 10.

Few candidates realised in Part (b) that a freebody vector diagram of the accelerated pendulum bob would allow them to find the horizontal component of the tension in the string and hence the resultant force and acceleration.

For one mark candidates were asked to state that the gravitational pull by the bob on the Earth was the Third Law partner of the weight of the bob. Only the better candidates scored this mark.

Question 2

At this level candidates should know that gravity does not reverse its direction. Yet when asked to sketch the velocity-time and acceleration-time graphs for a bouncing ball far too many candidates forgot this fact and only 25 per cent of them were able to score more than half of the marks.

Question 3

The performance on this Module 1 question was no better than that on the other two. The structured calculation in Part (c), which required candidates to calculate the kinetic energy of a crate sliding down a ramp by subtracting the work done against friction from the change in potential energy, proved to be too difficult for the average candidate.

In Part (b), surprisingly, few candidates realised that an object trav-

eling at constant speed could not possibly be gaining kinetic energy.

Module 2

Question 4

Bearing in mind that Part (c) awarded 3 marks for substituting in a given equation for the period of a mass oscillating on a spring to find the spring constant and Part (d) asked how changing g would affect the period for 2 marks, the mean score of 2.6 on this item was very disappointing.

The equations for S.H.M. were not well known and most candidates could not sketch graphs to show how the energy varied with *time* but used displacement on the horizontal axis instead (even if they wrote *time*).

Question 5

There was nothing in this question about total internal reflection that candidates would not already have encountered at CSEC level. Clearly they did not understand this topic and a weak mean score of 3.3 resulted.

Question 6

The performance on this lens question was only slightly better (mean 3.7/10) and most candidates needed more practice both in drawing ray diagrams and in doing lens calculations.

Module 3

Question 7

In 2003 the examiners pointed out a deficiency in candidates' knowledge of stress and strain. The message seems to have got home since this question was the only one on the paper to have a mean score greater than 5/10. Where candidates lost marks it was often due to careless use of units or the inability to handle powers of ten correctly.

Question 8

More candidates scored zero on this question than any other and more candidates scored full marks than on any other question. Perhaps the question was not difficult but the 25 per cent of the population who scored zero had never been exposed to the kinetic theory of gases in class.

Question 9

More than half of the candidates could score no more than 2 marks out of ten on this question about heat transfer. The graphs for the temperature drop across the wall of a boiler coated with scale were especially poor. The Examiners were merely looking for a larger temperature drop across the scale than across the copper wall. (Mean score 2.7)

UNIT 1

PAPER 02

Section A

Module 1

Question 1

Candidates were asked to analyse data, given in the form of a graph, concerning the motion of a ball rolling down a ramp and bouncing back from a barrier at the end of the slope. They did this poorly with only about 20 per cent of them able to achieve half marks. Perhaps more discussion in class of comprehension exercises such as this would improve the performance in future. A mean score of 2.5 out of 10 is hardly satisfactory.

Module 2

Question 2

Since many candidates could not write down the formula for the

resonance tube this question also had a low mean score (2.5).

Module 3

Question 3

The material in question 3, specific heat capacity, seemed to be much more well known as reflected by a mean score of 5.1. It was generally done well but marks were often lost by even the better candidates when they ignored the instruction to use the graph when finding the specific heat capacity of the block.

Section B

Module 1

Question 4

This question was not very popular, all but 52 candidates preferred to attempt Question 5.

Their answers to Part (b) about the motion of a geostationary satellite were for the most part quite satisfactory as were their calculations of the frequency of revolution for a mass undergoing horizontal circular motion. However their lack of understanding of motion in a vertical circle caused most candidates to lose the seven marks in Part (d).

Question 5

Candidates did better on this question than on any other on the paper. The mean score was only 9.4/20. The main errors were:

- Imprecise definitions and statements, for example, omitting if no external forces act from the momentum conservation law.
- Expecting, using data from an experiment, exact equality for momentum before and after a collision when asked if the data was *consistent* with the law.

- Not realizing that deciding whether a collision was elastic or not required calculations for the kinetic energy.
- Not taking direction into account in (b) (iv) and obtaining a total momentum of $2mv$ instead of zero

Module 2

Question 6

The responses to this question were generally poor. Of those who attempted it (about 300 candidates) only 10 scored half marks.

Most candidates scored some marks for the resonance-tube calculation in Part (b) but their understanding of refraction of sound waves, Part (a), and interference of sound waves, Part (c), was very limited. (Mean score 2.8/20)

Question 7

This was the more popular of the Module 2 questions and the mean score was better but still not satisfactory (4.9) Deriving the formula for the period of a simple pendulum proved to be surprisingly difficult for many candidates and the failure to understand the use of radians in the formulae for S.H.M. caused further substantial loss of credit.

Module 3

Question 8

With nearly 90 per cent of the population choosing to attempt this item, the examiners expected candidates to have a good understanding of calorimetry and thermal radiation. But they were to be disappointed. The level of the responses to Part (a) in particular were often below the standard that would have been required at CSEC level. At this level a candidate should know that *specific latent heat* involves unit mass of substance?

Stefan's formula for thermal radiation was unfamiliar to most candidates so that could score very few marks in Part (b). The more able candidates fared better in the calculations of specific latent heat and specific heat capacity in Part (c) but their weaker colleagues failed to understand that heating at a constant rate implied constant *power* and made little progress.

Question 9

Most candidates shied away from this question about the first law of thermodynamics. Those who did attempt it showed a poor grasp of the meaning of the terms involved and made heavy weather, except for sketching the graph correctly, of the thermodynamics problem in Part (b).

UNIT 2

PAPER 01

Module 1

Question 1

Evidence provided by the responses to this question would indicate that Kirchhoff's laws are not well understood by CAPE candidates. For example many thought the 2nd law applied to a *circuit* rather than any closed loop in a circuit.

If candidates had been taught to always draw the complete circuit they were using they might have made better headway with Part (b) whether they chose to utilise Kirchhoff or not. The responses to Part (b)(ii) were particularly poor with few candidates realizing that the 2 k Ω , and 3 k Ω resistors were connected in parallel. And many of the candidates who did follow the correct procedure had incorrect answers because they ignored 10³ factor in the given unit of resistance. (Mean 2.6/10)

Question 2

Strangely in Part (a) some candidates thought that the magnetic field around a current-carrying wire was elliptical or oval. Perhaps they

were misinterpreting the perspective in text-book diagrams? Many also had difficulty in drawing the combined field for a the wire and the Earth.

Although they had previously recalled the formula correctly candidates were frequently unable to apply it to the problem of finding the neutral point between two wires. A mean score of 3.2/10 was the mediocre result.

Question 3

The performance on this question about capacitors was much better (mean 5.9). Marks were often lost for defining capacitance imprecisely as *the ability to store charge*, for not stating that capacitors in series had the same charge in Part (a) and for being careless about the units in Part (b).

Module 2

Question 4

Most candidates recalled the formula $V=IR$ but few had any idea how to apply it. Familiarity with the potential divider would have made the problem-solving easier.

As mentioned above candidates continue to be very careless with unit prefixes so that even when they use the correct principles they still get the numerical answers incorrectly. A mean score of 2.7 was very disappointing.

Question 5

The performance on this straight forward question about transformers was satisfactory in the most part with a mean score of 5.8. Most marks were lost in the final part of the question where candidates were required to calculate the current in the secondary and then deduce the current in the primary.

Question 6

Because of its very high gain, the terminals of an op. amp. have to be

at virtually the same potential if it is not to be saturated. Teachers will need to emphasise this point which is generally poorly understood: many candidates attributed the virtual earth in the inverting amplifier to the fact that the ideal op. amp. has infinite input impedance.

The analysis of the unfamiliar amplifier circuit in Part (b) was done well by many candidates though some were very careless with the signs in their answers. (Mean 4.8)

Module 3

Question 7

The examiners were disappointed with the level of knowledge of the properties of the radioactive emissions in Part (a). Even the better candidates did not know that a magnetic field capable of significantly deflecting α -particles would cause α -particles to travel in a circle with a very small radius.

Many candidates were unable in Part (b) to relate the energy of electrons in an X-ray machine to the minimum wavelength of the X-rays produced which resulted in a mean score of only 4.3.

Question 8

Recall and understanding of the de Broglie relation and wave-particle duality were required to score a good mark on this item. The mean score of 3.1 out of 10 clearly shows that candidates, in the main, did not possess the required knowledge.

Question 9

The final section of this question, which required candidates to show that spontaneous emission of a proton by uranium-238 is not energetically possible, was poorly done but otherwise the performance was reasonable. (Mean 5.1)

UNIT 2

PAPER 02

Section A

Module 1

Question 1

This question was about an experimental determination of the e.m.f. and internal resistance of a battery by measuring the p.d. across various known loads. Most candidates showed a good understanding of the required circuit but their analysis of the data provided was very weak.

It is evident that candidates do not get enough practice in the laboratory with rearranging equations to get linear graphs and then interpreting the significance of the gradient and intercept. (Mean 4.3/10)

Module 2

Question 2

Candidates graphs of the transformer input versus output were often carelessly drawn and the determination of the number of turns in the primary winding from the graph=s gradient was not successfully completed by far too many candidates. A mean of 4.4 for such a question was very disappointing.

Module 3

Question 3

Again in Question 3 candidates' ability to extract information from a linear graph, even when the equation is provided, was highlighted. Much more laboratory work needs to be included in the Unit 2 programme if this deficiency is to be overcome. (Mean 3.1)

Section B

Module 1

Question 4

In Part (a), most students knew that the force was directly proportional to the product of the charges and inversely proportional to the square of the distance between them they could not also say that it acted along the line joining the two charges to get the third mark.

In the expression for the field experienced by a charge q_2 due to q_1 , candidates were confused as to which charge should be in the formula. However most were able to draw the field line diagram required in Part (iii).

Most candidates could not even score even one mark on Part (b) of this question since they did not understand that the proton and the electron, even though they had the same magnitude force acting on them, would not have the same acceleration.

In Part (c), candidates seemed to know the formula for the potential at a distance from a charge their problem solving skills were lacking and very few were able to successfully find the total potential at the centre of the square.

Surprisingly only one candidate scored more than half marks on this question. (Mean 3.9/20)

Question 5

The problem solving ability of most candidates was not up to the standard required to successfully find the mass of the unknown particle in Part (c). The main difficulty was in not realising that although accelerated through the same p.d. as the electron, the more massive particle would not acquire the same velocity.

The other parts of the question were reasonably well understood though some candidates found difficulty with the fact that a particle in motion in a circle has no work done on it by the centripetal force. (Mean 5.4/20)

Module 2

Question 6

The proof of the formula for the gain of a non-inverting amplifier was poorly done and very few candidates scored full marks for this.

Those who attempted Part (b) were able for the most part to correctly calculate the maximum input voltage for the given amplifier but Part (c) proved to be much more challenging even though the same formula was required again.

The use of an inverting amplifier as a summing amplifier in Part (d) was not well known and resulted in most candidates losing these 4 marks. (Mean 5.4)

Question 7

Although this digital electronics question was quite popular, and the mean of 7.7 was better than for the alternative analogue electronics question, it still showed up several weaknesses. For example candidates were able to draw up truth tables for the gates correctly but not the table for a combination of gates. And the explanations of the operation of both the half-adder and the full-adder were very confused. The description a couple of sums might have improved candidates scores significantly. The fact that most candidates were able to determine correctly the sum and carry in Part (b) (iv) would seem to indicate that it candidates= writing skills rather than understanding that is the problem in this case.

Module 3

Question 8

Very few candidates attempted this question and only one of those scored half marks.

The explanations of the production X-ray spectra were lacking in detail and few of those attempting Part (a) indicated that the minimum wavelength occurred when the incident electrons lost all of their kinetic energy in collisions with nuclei.

Rather than basing their choice of filtering material in Part (b) (ii) on the photon energies calculated in Part (b) (i), candidates preferred to use guesswork and so lost the available marks. The mean score of 3.0 out of 20, and the small number of candidates choosing this question, seems to indicate that more attention needs to be paid to this syllabus area.

Question 9

Although the mathematical problem in Part (c) was challenging the examiners expected that candidates would be able to score heavily on the early parts of this question so a mean score of 4.3 was very disappointing. Many candidates started badly by not even being able to explain the meanings of the symbols in the given radioactivity equation. This was followed by a failure to quote the equation $A = \lambda N$ and thus an inability to derive the required half-life equation.

Candidates were generally able to find the half-life from the given graph in Part (b) though few bothered to make more than one estimate and take the average. Part (iii) proved to be difficult however since few candidates noticed the link to the formula already given in Part (a)(ii).

SBA Moderation

The examiners are of the opinion that in both Unit 1 and Unit 2 the quality and quantity of the practical work needs to be improved. It was again noted this year that very often the experiments were repetitions of those already performed during the CSEC course and the spread of activities across the modules was uneven. With the removal of the project component in 2005 it is expected that a minimum of five experiments would be performed in each of the modules.

Even in topics where apparatus is limited, such as modern physics, experiments at a suitable level which develop the required data analysis skills can be found. For example:

Finding the half life of the discharge of a large capacitor.

Using dice (or cubes with one face painted black) to represent radioactive decay.

Testing whether the flow of water from a burette is exponential.

Using a light emitting diode to determine Planck's constant.

A number of centres entered CAPE Physics for first time this year and their mark schemes were not always consistent with the CAPE specifications. It is hoped that as they gain more experience teachers will be able to more accurately select the criteria required to test each skill and the moderators will less frequently have to resort to replacing teachers' scores with their own.

CARIBBEAN EXAMINATIONS COUNCIL

**REPORT ON CANDIDATES' WORK IN THE
CARIBBEAN ADVANCED PROFICIENCY EXAMINATION
MAY/JUNE 2005**

PHYSICS

**Copyright © 2005 Caribbean Examinations Council ®
St Michael Barbados
All rights reserved**

PHYSICS**CARIBBEAN ADVANCED PROFICIENCY EXAMINATION****MAY/JUNE 2005****GENERAL COMMENTS****UNIT 1**

The number of candidates entered for Unit 1 continues to rise: this year there were approximately 50 per cent more candidates than in 2004.

The performance on Modules 1 and 2 improved somewhat from the previous year with mean scores of 48 per cent and 49 per cent of the maximum score respectively. However the performance on Module 3 (Thermal and Mechanical Properties of Matter) remained weak with a mean score of only 41 per cent of the maximum score.

None of the Module 3 questions on either paper elicited good scores suggesting to the examiners that perhaps this section of the syllabus does not have enough time spent on it. Certainly some aspects, for example, radiation, kinetic theory, seemed not to have been taught by many centres.

UNIT 2

The number of candidates entering Unit 2 almost doubled compared to 2004 and the mean composite score improved slightly from 43 per cent to 46 per cent.

Again in this unit, Module 3 had a lower mean score (40 per cent) compare to the other two modules (44 per cent for Module 1, 49 per cent for Module 2). Some may feel that Atomic and Nuclear Physics is more difficult than the other areas but it seems more likely that the explanation for the poor performance may lie in problems with completing the syllabus in the teaching time available.

Teachers who are aware of the problems this year in Module 3, in both Units, may wish to look carefully at their teaching schedules to try to ensure that the three modules receive equal weighting.

DETAILED COMMENTS**UNIT 1****PAPER 1****Module 1**Question 1

This question tested candidates' knowledge of Newton's laws of motion and the use of vectors and there were many excellent responses. Where marks were lost it was often in the last part of the question: candidates were expected to point out that there was a zero resultant force in the direction under discussion.

The examiners only disappointment was the number of candidates who had imprecise statements of Newton's laws - mentioning an *unbalanced* or *resultant* external force is essential in the first law and, without further explanation, "action and reaction are equal and opposite" is not acceptable for the third law at this level.

Question 2

A mean score of 4.6 out of 10 on this item about alternative energy sources is not satisfactory. Most of the marks were lost for the calculation in (c), perhaps because there was no rehearsed formula to apply. Candidates had first to find 15 per cent of 300 W m^{-2} and then use that value to calculate the area needed to supply 25 MW of power. This was, surprisingly, beyond the ability of most.

Question 3

A disappointingly high number of candidates scored 0 or only 1 mark on this kinematics question. They could not draw the graphs for the motion nor could they use equations of motion to find the velocity of a ball thrown vertically upwards.

The discussion of the effects of air resistance in Part (d) was beyond most candidates. The examiners were merely expecting them to apply the fact that the air resistance depends on the speed of the ball and, since it opposes the motion, changes direction at the top of the trajectory.

Module 2Question 4

There was a wide spread of scores on this question. Some candidates could only score the mark for finding the spring constant in (a) whilst many others were able to

score full marks. Careless calculation of errors, especially in the use of units, accounted for the loss of marks by the other candidates.

Question 5

Generally the responses to this question were satisfactory with most candidates demonstrating a clear understanding of refraction and total internal reflection. Credit was given to candidates who pointed out that the angle of incidence given was greater than the critical angle as well as those who proceeded to calculate the refractive index from a point on the graph.

Question 6

This question about the correction of long sight received many poor responses. Very few candidates knew that the image formed by a spectacle lens has to be virtual and, therefore, could not gain credit in Part (c).

The diagrams in Part (d) were of a particularly low standard and candidates were unable to deduce that while looking at a distant object the reading glasses would produce a real image behind the viewer's head.

Module 3

Question 7

Careless errors in the calculations and the poor use of units contributed to candidates' mediocre scores on this question about the stretching of materials.

Question 8

It seemed that few candidates had studied radiation and the application of Stefan's law. The idea that an object would be radiating energy and receiving energy at the same time was not understood by the minority who were familiar with the law. Consequently, the scores on this question were low.

Question 9

In this question a graph was provided showing the changes in pressure and volume of a sample of gas. The requested descriptions of the processes occurring were reasonable but the calculations of the work done were very poor. In Part (iv) a disappointingly small number of candidates realised that the change in internal energy for a whole cycle would be zero.

UNIT 1**PAPER 02****Section A**Question 1

Though there was a large number of candidates scoring more than 8 out of 10 on this question there was an equal number of candidates with such poor laboratory experience that they could score no marks at all.

Many candidates, though they correctly filled in the log values in the table, did not proceed to plot the required log graph to find n . The examiners feel that, at this level, candidates should have acquired the skills to analyse data involving power laws. Perhaps more laboratory exercises involving such relationships could be introduced into the schools' practical programmes.

Question 2

The attempts at Question 2 were much better than those for Question 1, the mean score being higher than 5 out of 10. But even so some of the graph plotting was quite inaccurate and the curve drawing was often poor. Few candidates understood that the resonant frequency of the driven pendulum was equal to the natural frequency of the driver pendulum and consequently some candidates lost credit for Part (d).

Question 3

Candidates were expected to know that the uncertainty in reading an instrument is usually estimated as half of the smallest division and then use this uncertainty in each reading to estimate the error in the value of a calculated specific heat capacity. Though most candidates knew that they were to add the fractional errors in each term of the given equation, their calculations were often inaccurate. The most common problem was the failure to calculate the error in the temperature difference rather than the individual temperatures.

Section B**Module 1**Question 4

This was the more popular of the two Module 1 questions but the mean score was less than 40 per cent. The main difficulties were:

- Failure in Part (a) to convincingly show that kinetic energy was *not* conserved in the prediction of Part (iii) but was conserved in Part (iv) even though momentum was conserved in both cases.

- Not recognising that momentum is a vector quantity in (b) and, therefore, neglecting its direction.
- Attempting to use equations of constant acceleration in (iv) and then using $F = ma$ when clearly the force was varying as shown by candidates own sketch graphs. Teachers may need to emphasise more the general form of Newton's second law which states that the force is equal to the rate of change of momentum.

Question 5

This question was much less popular than Question 4.

In Part (a) the explanations of the forward thrust on a light aeroplane were very sketchy and few candidates were able to successfully calculate the mass of air flowing per second.

In Part (b), although most candidates were able to calculate the centripetal force on a banking aircraft their understanding of the vector nature of the external forces involved was poor and they gained few marks for the other sections. In particular few understood that the force exerted on the passenger by his seat must have a horizontal component so that the passenger could also follow a circular path.

Module 2

Question 6

Although many candidates were able to successfully complete the diffraction grating calculations, they did not demonstrate that they actually understood the principle of the grating. The explanations of how the spectra were formed were very disappointing.

As in other questions the incorrect conversion of units, in this case **nm** and **mm**, proved to be the downfall of some candidates and caused their scores to be lower than they might have been.

Question 7

The majority of candidates who attempted this question scored less than 8 marks out of 20.

Candidates gained most of their marks in Part (a) where they were able to reproduce the derivation of the double slit formula. In Part (b) they demonstrated little understanding of interference and how it occurs. Few realised that speakers 1.5 m apart could not be regarded as a point so the formula for light would not apply especially if the observer was only 6 m away.

Module 3Question 8

Though this question was just as popular as the other module 3 question, the responses, especially in Part (b), were very poor. Candidates might be reminded that it is best to read through the whole question before starting rather than “jumping in” because the first part looks familiar.

The attempts at graph sketching in Part (b) clearly showed that candidates did not understand that an insulator has a much larger temperature drop across it than a better conducting material even though they were able to calculate that 20 cm of plywood would be needed to have the same effect as 1 cm of plastic foam.

Candidates were given a choice (Part (b) (iii)) of using the equivalent conductor determined in (ii) or using the heat flow equation to find the rate of conduction. In fact, for the most part, they could do neither and gained very little credit.

Question 9

A large proportion of those attempting this question on the kinetic theory of gases scored no marks at all and there were very few candidates scoring more than 50 per cent.

Few candidates knew the meaning of *r.m.s. speed* so it was not surprising that the derivations of the formula in (a)(iii) were rarely worth more than one or two marks, nor that candidates calculations in Part (b) went astray so often.

UNIT 2**PAPER 01****Module 1**Question 1

Many candidates scored zero or only one mark on this question about drift velocity leading the examiners to believe that this part of the syllabus had been neglected by some centres.

For those who could attempt the question, Part (b) proved to be quite challenging, even the straightforward determination, Part (i), of the number of electrons flowing per second having been given the charge flowing per second. In Part (ii) even the better candidates failed to deduce that the charge would be equivalent to $4e$ and the formula would become $I = 4nevA$.

Question 2

This question also proved to be quite challenging. Candidates usually gained marks for stating the formulae in (a) but did not know that the electric field was equal to the (negative) potential gradient.

The principle in (b) should not have been difficult: induced charges on the sphere cause it to be attracted to the nearer plate and then repelled when it becomes positively charged. But few candidates were able to score marks here. The calculations in Part (iii) were generally satisfactory though some candidates did not substitute in the equation values with the correct base units.

Question 3

Faraday's Law and Lenz's Law were quite well known but the explanations of the connection of the latter with conservation of energy were poor. Only the better candidates were able to score the marks for the calculations of flux and induced e.m.f. in (c).

Module 2Question 4

A large proportion of the candidate population could score no marks on this op. amp. question and there were few really good responses.

For those candidates familiar with the topic the greatest weakness was the inability to relate the small input voltage required for saturation (60 mV) to the amplitude of the signal (0.2 V) and deduce that the op. amp. output would always be saturated at 12 V .

Question 5

The performance on this question was quite commendable with a sizeable number of candidates being able to score 80 per cent or more.

Surprisingly, the I-V characteristic (a) (i) was the place where marks were most often lost. Teachers might wish to pay particular attention to this graph and include it in their laboratory programme. The silicon diode will be found to turn on when the forward voltage is about 0.6 V and if the same scales are used on the negative axes as those on the positive axes, there will be no detectable current in reverse bias.

Question 6

Candidates seemed to be much more comfortable with digital electronics than they are with the analogue version (cf. Q.4) perhaps because it is first introduced at the CSEC level.

Generally the performance was satisfactory except for (b)(ii) where, even though they might have drawn up the correct truth table for the circuit, many candidates

were unable to draw the relevant timing diagrams.

Module 3

Question 7

X-rays are produced by two processes: when the electrons are rapidly slowed down by the target their energy is converted to high frequency electromagnetic radiation with the highest frequency (or shortest wavelength) being produced when they are completely stopped. Also electrons in the target metal atoms gain energy and move to a higher energy level before dropping back down to their original state and producing radiation with a frequency characteristic of the particular metal. The responses to this question showed that the average candidate had grasped neither of these concepts.

Question 8

There was a wide spread of marks for this radioactivity question. Generally the theory was quite well known but some candidates made careless mathematical errors.

Teachers might wish to note that some candidates solved (b) (iii) more quickly by working out that the given time is 1.56 half-lives ($= p$) and then using $A/A_o = 1/2^p$.

Question 9

The labelling of the Geiger-Muller tube was done very poorly and few candidates could explain how the tube worked. And not many candidates knew that alpha particles ionise the air they pass through, losing energy in each collision, and therefore can only travel a few centimetres in air. For these reasons the mean score of 3.0 was much lower than expected.

UNIT 2

PAPER 02

Question 1

Some candidates chose inappropriate scales for their graphs, or plotted them carelessly but, in general, candidates graph work was up to the required standard. Most candidates understood how to use the graph to find the permeability from the given formula and completed the calculation successfully.

Question 2

Candidates were able to interpret data from the graph and score marks in Part (c) and most understood the concepts of gain and bandwidth. However, the use of the oscilloscope to measure the gain of an amplifier seemed to be unfamiliar to many

candidates and accounted for the modest performance overall on this question.

Question 3

The standard technique at this level for dealing with data which have an exponential relationship is to plot a linear graph using natural logs. The examiners were disappointed to find that many candidates were unable to do this. Some of those who could, made careless errors in the calculation of the half-life from the gradient of the graph.

Module 1

Question 4

The successful use of Kirchhoff's rules to analyse d.c. networks requires that the equations be constructed very carefully, paying particular attention to the signs of the quantities. Most candidates were unable to do this, which resulted in a disappointing mean score of 6.2 marks out of 20.

Question 5

This question on the Hall effect was much less popular than Question 4. Once the idea of an electric force being set up to cancel the magnet force on the charge carriers was understood candidates were able to score reasonable marks on the various parts of this question and the mean score was 9.0 out of 20.

As pointed out elsewhere candidates seemed to have difficulty with dealing with the prefixes of units and, therefore, lost marks by having incorrect powers of ten in their answers.

Module 2

Question 6

Although the average candidate could draw a reasonable diagram of the transformer, his/her written explanation for the choice of materials was often incomplete. The choice of pure iron so that energy losses due to hysteresis would be reduced was not well understood: being "easy to magnetise" was considered inadequate at this level.

The responses to Part (b) were generally satisfactory but Part (c) proved to be difficult for most candidates who took the supply p.d. to be the same as the voltage drop across the cables and ended up with enormous energy losses.

Question 7

The attempts at this digital electronics question were disappointing. The operation of the bistable flip-flop as an electronic latch in Parts (a) and (b) was not familiar to many candidates.

In Part (c) the half-adder and full adder were better understood and candidates gained more credit in this section. However it was disappointing to see a number of candidates using a circuit to add $1 + 0 + 1$ and getting the answer to be 1 or 3.

Module 3

Question 8

This question tested candidates' knowledge of the photoelectric effect and the use of Einstein's equation.

Most candidates were able to gain marks in Parts (a) and (b) since they demonstrated good overall knowledge of the photoelectric effect. It disappointed the examiners, therefore, that the marks for Part (c) were so low - here an organised systematic approach to problem solving was needed which most candidates did not demonstrate.

Candidates had great difficulty with dealing with the fact that only 5 per cent of the incident photons would be absorbed and did not manage to deduce the number of electrons emitted per second from the available intensity and the energy of each photon.

Some candidates were more successful in (c) (iii) and (iv) but many candidates were stumped because they did not know that the work function could be calculated from the given threshold frequency.

Question 9

The responses to Part (a), testing candidates' knowledge of nuclear fission and fusion, were not of the standard expected at this level. The use of the binding energy curve to explain why fission and fusion are energetically favourable is standard in the texts so it was thought that the connection between stability and binding energy would be well known.

The calculation of the energy released in a given fission reaction was performed successfully by many candidates but they stumbled in their use of reasoning to reach a final value for the energy per kilogram. The mean score of 6.0 out of 20 was thus quite disappointing.

INTERNAL ASSESSMENT

The examiners were again disappointed by the depth and breadth of the practical work submitted for review. Some centres could only manage to perform six experiments in a whole year. This is clearly inadequate since skills have to be developed and practised before the teacher makes an evaluation of the candidates' progress.

Often the laboratory exercises did not reflect the content of the CAPE syllabus but were simple experiments which could have been performed at CSEC level, for example testing materials to see whether they conduct electricity using a battery, lamp and connecting wires.

It is important for candidates to see their laboratory work as an integral part of their learning experience, closely linked to the work they are doing in the "theory" classes, and they would, therefore, expect the work submitted for moderation to be spread evenly across the three modules in each Unit.

There was also some concern, particularly in Unit 1, about the small number of exercises involving graphs. At this level the use of graphical techniques to analyse data is very important and it appears that candidates need much more practice to improve these skills.

CARIBBEAN EXAMINATIONS COUNCIL

**REPORT ON CANDIDATES' WORK IN THE
CARIBBEAN ADVANCED PROFICIENCY EXAMINATION
MAY/JUNE 2007**

PHYSICS

PHYSICS
CARIBBEAN ADVANCED PROFICIENCY EXAMINATION
MAY/JUNE 2007
GENERAL COMMENTS

Unit 1

A slight increase in the candidate population returned scores similar to that in previous years. The new Paper 01 (Multiple Choice) performed well. There were four items out of 45 in which less than 30 percent of candidates gave the correct response.

The performance on Paper 02 was good except for a question on error calculation and one on refraction where the scores were very low (see detailed comments).

Unit 2

There was a large increase in the number of candidates sitting Unit 2 and the performance overall was much better than previous years.

Both Units

One weak area which stood out for the examiners, however, was in the analysis of results of experiments. It appears that candidates neither see nor do experiments in magnetism and analogue electronics and are faced with quite unfamiliar observations in the examination room to interpret questions set on these topics. The time honoured practice of candidates doing or “rotation” of labs where apparatus is more expensive has much to commend it at this level.

DETAILED COMMENTS

UNIT 1

PAPER 01

Module 1

Performance on most questions was generally satisfactory. The three lowest scoring items with only about 30 percent of the candidates giving the correct response were:

- Determining the relationship between velocity and mass for an object moved a fixed distance by a constant force $v^2 = \frac{2F}{m} x$ So $V \propto \sqrt{x}$.
- Finding the torque of a couple.
- Understanding that an object falling at constant velocity has zero resultant force.

Module 2

There were good responses to questions on the general principles of wave-motion but two glaring weaknesses were noted: candidates did not understand two-source interference and they were unable to apply the lens formula to the formation of an image by a diverging lens.

Module 3

Plotting a graph for the variation of an empirical temperature θ with thermometric property X was beyond most candidates. The use of Stefan's Law also proved problematic. Otherwise the items in this section were not found to be difficult with one disappointing exception; when candidates were asked to find the volume of one atom of copper from given molar data, the majority of candidates instead found the volume of a mole of copper.

Unit 1**Paper 02****Section A**Question 1

The poor performance on this question (mean 2.6 out of 10) makes it obvious that candidates did not have enough practice in calculating the uncertainty in physical quantities by combining the estimated errors in measurements.

Even when candidates deduced that L was 19.2 ± 0.4 cm in part (a), often they could not say that the diameter D (= L/10) was 19.2 ± 0.4 cm. It was not surprising thereafter that combining the results to find the uncertainty in the density of the metal (part (c)) proved to be beyond most candidates.

The examiners would like to suggest that teachers of this difficult area of the syllabus, try using the method of adding the **percentage** errors in the quantities rather than the traditional method of writing an equation relating the fractional errors. Perhaps this would prove to be less confusing for the students.

For example: Percent error in D = $0.04/1.92 \times 100 = 2.1\%$

Percent error in V = $3 \times \% \text{ error in D} = 6.3\%$

Percent error in m = $0.3/30.4 \times 100 = 1.0\%$

Percent error in density = $6.3\% + 1.0\% + 7.3\%$

and the final value for the density becomes 8.2 ± 0.6 g cm

Question 2

For most candidates this data analysis question should have been quite straight forward even if the actual experiment on cavity resonance was unfamiliar. However, two main difficulties arose:

- Candidates made plotting and reading off values hard for themselves by choosing odd scales for the graph (for example, 1:3, 1:7, etc.)
- Candidates had difficulty relating the gradient of the graph to the quantities in the given equation and so could not determine the velocity of sound (mean 5.8 out of 10).

Question 3

Again in this question about the determination of Young modulus. Candidates often stumbled over the connection between the gradient of a graph and the constants in the equation. The technique of using a linear graph to find a good average value of a physical quantity is commonly used in physics and practice is needed in this area.

The fact that candidates were not able, for the most part, to measure the area under the graph (part (b)) compounded their difficulties and so the mean for this question was a low 4.7 out of 10.

Section BModule 1Question 4

There was evidence that most candidates knew the principles involved in this question about vectors and static equilibrium but their scores were limited by their poor problem solving ability (mean 9.5 out of 20).

The examiners expected, at this level, that the vector addition in **part (a)** would be done by means of resolution and then addition of the components. However, attempts using scale drawings or triangles of forces were also accepted. In the latter case, candidates' trigonometry was poor and the few using this method gained much credit.

The scale drawings offered were usually much too small and even in those which were not the angles, were measured carelessly. The final values for the resultant were thus not very accurate.

Some of the better candidates drew up a table showing the relevant components and their direction (see below). This method has much to commend it in terms of clarity and avoidance of errors.

force	x component	y component
35 N	14.8	31.7
24 N	20.8	-12
20 N	-14.1	-14.1
R	+11.5	+5.6

Disappointingly a significant number of candidates, after getting the correct components, were unable to show the correct direction for the resultant. They thoughtlessly drew the remaining side of the triangle as in the diagram on the next page.

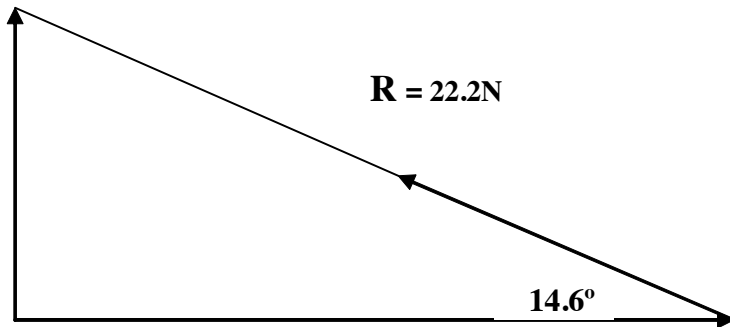

Most attempts at the standard statics problem in **part (b) (ii)** were poor even though the free body diagram was given in the question. Candidates did not seem to realize that they needed to apply the same principles they had expounded in part (i).

- (a) The upward force R must be equal to the weight of 200 N
- (b) The clockwise moment of P about the base of the plank would be equal to the anticlockwise moment of the weight ($P \times 6 = 200 \times 1.5$ and so $P = 50$ N)
- (c) The horizontal forces are equal and opposite so $F = P$. Combining F and R yields a resultant of 206 N, 76° to the ground.

Question 5

The mean score for this question was similar to that for the alternative Question 4. Candidates demonstrated for the most part a good grasp of the concepts tested in parts (b) and (c) and scored well. It was disappointing, however, to see the number of answers in part (b) (iii) with the input power of the motor being less than its output. Surely candidates should have realised that they had the formula inverted and corrected their mistake.

In contrast the responses to part (a) (ii) were poor! Expecting candidates to know that g would not be constant over a large distance, the examiners were surprised to find instead that either gravity had been switched off ($g = 0$) or had been used up in providing the centripetal force.

In part (a) (iii), very few candidates were able to translate the principle that the *change* of kinetic energy was equal to the *change* of potential energy into a meaningful equation. Instead they ignored the initial kinetic energy of the roller coaster and wrote $\frac{1}{2}mv^2 = mgh$. The marks awarded in this part were consequently very low (mean 9.5 out of 20).

Module 2

Question 6

Part (a) tested candidates' knowledge of standing waves and the properties of sound. The answers were of varying quality. Some candidates had not understood that stationary waves are formed from two waves of the same type and frequency travelling in opposite directions. Perhaps if they had the opportunity to experiment with waves on strings, microwaves and sound waves in the laboratory, they might have had a better grasp of the concept. The words *subjective* and *objective* gave some candidates difficulty in part (a) (iii). The examiners were expecting candidates to associate, for example, loudness (subjective) with amplitude (objective) or pitch (subjective) with frequency (objective) etc.

Part (b) concerned intensity and intensity levels in decibels. Whilst parts (b) (i) and (ii) were answered successfully by most candidates, part (b) (iii) proved to be difficult since it required a two stage calculation – the pain threshold, 120 dB, corresponds to an intensity of 1.0 W m^{-2} and then the use of the given proportionality gives a distance of two metres from the speaker. Although the question clearly stated otherwise many candidates floundered because they assumed that they could use the *intensity level* in the proportional relationship (mean 7.3 out of 20).

Question 7

The mean score on this question was a disappointing 4.3 out of 20. This was quite a shock to the examiners since some of the content was at CSEC level and much of the remainder was merely an extension of that work. In fact the only section in which the responses were satisfactory was part (c) which contained material introduced at CAPE.

In part (a) many candidates could not define the refractive index for light waves as the ratio of the speed in the medium to the speed in a vacuum (or air), nor could they draw a diagram of wave refraction so deriving the law of refraction in part (iii) proved to be beyond them.

The use of the given law of refraction in part (b) was very poor. In fact, many candidates tripped themselves up by resorting to the (misunderstood) use of the out-moded idea of relative refractive index. The examiners would like to recommend that, to avoid such errors, teachers **always** use the law of refraction in the form given in this question: $n_1 \sin \theta_1 = n_2 \sin \theta_2$.

Module 3

Question 8

Only a small proportion of candidates attempted this question rather than Question 9. Those with good mathematical skills were able to handle the exponential formula in part (b) well and score heavily on this part. However, the responses to part (a) about the use of thermometers were relatively poor (mean 3.6 out of 20).

Question 9

There was a wide spread of mediocre marks on this question (mean 7.8 out of 20).

Poor expression was the downfall of many candidates in part (a) (i). Though they knew that pressure is force/area they had difficulty relating that to collisions with walls, change of momentum, etc. as required for the kinetic theory of gases.

The application of $pV = nRT$ in part (a) (ii) proved to be challenging. It seemed that some candidates had learned the gas law at a lower level without the inclusion of the amount of gas, ($p_1 V_1 / T_1 = p_2 V_2 / T_2$) and were unable to cope with the situation where more oxygen was pumped into the cylinder. Since unlearning is often difficult, teachers might be able to prevail upon those teaching at a lower level to include the n factor from the start and discuss such obvious examples as pumping up car tyres and filling cylinders -

Part (b) was about the first law of thermodynamics elicited many good responses though the usual confusion about the signs for energy added (work done ON the gas) and energy lost (work done BY the gas) frequently occurred.

UNIT 2**PAPER 01**

The mean score on this paper was a commendable 64 percent and there were strong responses (with more than 80 percent of candidates correct) in various areas such as electric circuits, capacitors, digital electronics, photoelectric effect and X-rays.

The items causing the examiners concern are listed below. Perhaps teachers will be able to spend a little time straightening out these common misunderstanding with future classes.

1. A variable resistor in PARALLEL to a component will not be able to change the current through it.
2. Doubling the diameter of a wire will cause the resistance to change to a quarter of the original value if other factors are constant.
3. The r.m.s. value of an alternating current is the same as the value for the direct current which causes the same power to be dissipated.
4. A non-inverting amplifier may be easily recognised by the fact that the input goes to the positive terminal of the operational amplifier and its gain is found by adding one to the resistance ratio

$$(A = \frac{R_2}{R_1} + 1).$$

PAPER 02**Section A****Question 1**

In this question candidates were provided with data to plot a graph showing the variation of the magnetic field along the axis of a solenoid. Generally the plots were good but the examiners were surprised at the substantial minority who used “dot-to-dot” rather than drawing a straight line followed by a smooth curve to show the weakening field near the end of the coil.

Part (c) was not done well. Only the better candidates recognized that the formula could only apply to the uniform field near the centre and that the field at the end was half that at the centre.

Disappointingly few candidates were able to gain the two marks in part (d) for using the formula to find the TOTAL (in capitals) number of turns in the coil (mean 4.9 out of 10).

Question 2

This question tested the use of the operational amplifier as a comparator. The principle that the op amplifier output would saturate at positive 6V or negative 6V depending on which input had the higher potential was not understood by most candidates. This led to low scores in part (b) and a mean score overall of 4.7 out of 10.

Although most candidates gained the available marks for plotting the thermistor calibration curve teachers might wish to note the following:

- Students need to be exposed to a variety of graphs in their practical work, not only linear graphs.
- They also need practice in choosing suitable scales so that the graphs are large enough without resorting to, for example, factors of three which lead to read-off difficulties.

Question 3

The response to this question were much more satisfying – many candidates scoring eight or more out of ten (Mean score 6.2 out of 10). For those scoring less, the main weakness was that they did not realise that they could read $\ln I_0$ from the axis even though the scale on that axis did not start at zero: since the x-scale (absorber thickness) did begin at zero the intercept was in fact $\ln I_0$. Candidates who instead tried to calculate the value found the mathematics difficult and often failed to obtain the correct value.

Section B

Module 1

Question 4

A significant number of candidates had such inadequate understanding of electric circuits that they chose this question but could not score any marks. The mean score of 4.3 out of 20 does not therefore reflect the fact that others performed much better.

In part (a) candidates were not entirely clear on the difference between e.m.f and terminal p.d. even though they were able to define the terms. Teachers need to reinforce the idea that there is a “loss” of energy due to the internal resistance of the battery and so the energy delivered to the terminals will be less.

The majority of candidates were unfamiliar with the procedures in determining the e.m.f of a battery using a potentiometer: many could not even draw the circuit correctly.

In calculating the internal resistance of the cell in part (iv) many candidates tripped themselves up by using the e.m.f rather than the p.d. to calculate the circuit current. For many candidates at this level any voltage can be used in $V=IR$ to find the current and teachers will need, over and over again, until they get out of the habit, to emphasise to students that they must have the correct voltage across the component before calculating. (It might be noted that a similar error occurs in part (b) of Question 6)

In part (b) many candidates were unable to derive the correct set of equations using Kirchoff’s first and second laws. Most commonly they failed to adhere to the sign conventions with regard to traversing the loops in the circuit. Even those with the correct equations were not always successful in arriving at the correct values since they were let down by their inability to solve simultaneous equations.

Question 5

The performance on this popular item was much better than that on Question 4: several candidates scored full marks and the mean of 10.3 out of 20 was better than any other question on the paper.

Marks were lost in part (a) because candidates could not define the farad and often did not understand what *dimensions* meant with reference to a capacitor (capacitance depends on the area of the plates and the distance between them).

Though part (c) was generally well done, there were many candidates who, despite their correct use of the same concepts in the derivations required for part (b), thought that each of the series capacitors had a p.d. of 6 V across them and proceeded to calculate different values for their charges. Other careless mistakes such as not inverting ($1/C = \frac{1}{4}$ therefore making the capacitance $\frac{1}{4}$ microfarad), forgetting to square V in $E = \frac{1}{2} CV^2$ and leaving out the 10^{-6} factor contributed to unnecessary loss of credit.

Module 2

Question 6

With a mean of 5.1 out of 20, the performance on this question was not very satisfactory. Many candidates had learned about the operation of a p-n junction and scored marks on part (a), but the applications of the junction diode in parts (b) and (c) were not well understood.

Part (b) required candidates to see that an L.E.D would turn ON when a p.d. exists across it, that is, when one end has a positive potential and the other is grounded. Many did not grasp this point. Those that did, failed to understand that they needed to calculate the p.d. across the resistor ($V = 15 - 2 = 13$ V) before they could use $V = IR$ to find the protective resistance used.

The responses to part (c) were even poorer with few candidates realising that the p.d. across the diode must be 0.7 V (as shown in the given characteristic) while it is conducting. Thus the peak value of the resistor's p.d. would be 0.8 V and its peak current 0.8 mA.

Since candidates generally ignored the "turn on" voltage of the diode the sketch graphs in part (c) (iii) were very poor with most candidates only gaining a mark or two for showing the general principle of rectification.

Question 7

Some candidates had obviously studied this section of digital electronics quite thoroughly and there were some excellent scores from the better candidates. However, the mean score was disappointing (6.1 out of 20) as other candidates were unable to apply their knowledge to unfamiliar situations.

In part (a), only part (ii) of this section proved to be problematic. Many candidates seemed to be unfamiliar with the use of one type of logic gate (NOR in this case) to construct the others.

In part (b), though the diagrams of flip-flops were good, the explanations of their operation as a latch were not. Similarly the deductions of the action of the triggered bistables connected as a counter (part (ii) seemed to be wild guesses rather than the use of the given principle).

The use of the operational amplifier as a summing amplifier seemed to be familiar to most candidates but many made careless errors such as missing out the input voltages of 5 V (or using one volt instead) after writing the correct formula for the circuit.

65

Module 3

Question 8

The distribution of scores on this question was unusual: either candidates performed well and scored more than 15 or their responses were poor less than four out of 20. Perhaps this reflected the fact that some were able to handle the mathematics of radioactive decay comfortably whilst others struggled to get started.

CARIBBEAN EXAMINATIONS COUNCIL

**REPORT ON CANDIDATES' WORK IN THE
CARIBBEAN ADVANCED PROFICIENCY EXAMINATION
MAY/JUNE 2008**

**PHYSICS
(TRINIDAD AND TOBAGO)**

**Copyright © 2008 Caribbean Examinations Council ®
St Michael, Barbados
All rights reserved**

PHYSICS
TRINIDAD AND TOBAGO
CARIBBEAN ADVANCED PROFICIENCY EXAMINATION
MAY/JUNE 2008
GENERAL COMMENTS

The performance of the candidates in the 2008 examination was similar to that of the 2007. The mean score on the multiple choice paper remains significantly higher than that of the written papers. The examiner sees the need for candidates to gain more experience in problem solving and in analysis and interpretation of graphical data.

UNIT 1

PAPER 01

MULTIPLE CHOICE

Module 1

The mean score for the 15 questions on this mechanics module was 52 per cent with candidates scoring best on items about units, momentum, projectile motion and satellite motion.

An item requiring knowledge of the balanced forces on an object falling at terminal velocity proved to be the most challenging and tripped up more than 80 per cent of the candidates: there still seems to be a pre-Newtonian belief persisting that motion requires a resultant force. Another item about wind blowing on a door was also poorly done since few candidates realised that the resultant force would act at the centre of mass.

Teaching of Newton's 2nd law in the form $F_{\text{RES}} = ma$ might help students to remember to the resultant force before applying the law. In the case of an item on vertical circular motion it might have prevented candidates from making the error of calculating the tension in the string by equating it to mrT^2 .

Module 2

The performance on this Waves module was much better than that on the mechanics (mean 62 per cent correct) with candidates doing particularly well on items involving the energy of a pendulum, pitch and loudness, comparison of properties of light and sound waves and graphs for stationary waves.

The weak areas were:

The calculation of the focal length of a lens to correct long sight proved to be too difficult for most candidates.

Candidates did not know that the colours observed in a thin film are due to interference rather than refraction.

The calculation of the frequency of standing wave on a stretched string involved two steps - finding the wavelength and using $v = f\lambda$. Less than 40 per cent of candidates were able to do this.

Module 3

Candidates, on average, responded correctly to 57 per cent of these items. The poorest responses came for a Boyle's law item about a rising bubble - the majority of candidates ignored the atmospheric pressure in their calculations.

There were however many areas where candidates seem to have been well prepared including thermometers, temperature scales, cooling curves, conduction in metals and Young's modulus.

UNIT 1

PAPER 02

Question 1

Generally the graph of the motion of an object falling under gravity (Part (a)) was well done. But many candidates lost marks unnecessarily e.g. by using the table to calculate the gradient instead of identifying a large gradient triangle on the graph paper or by assuming the gradient was equal to g rather than $\frac{1}{2}g$.

Surprisingly at this level not many candidates could correctly draw all three sketch graphs for the variation with time of acceleration, velocity and displacement (Part (b)) and there were even candidates who were quite unaware that one of the equations for motion with uniform acceleration was required in Part (c).

Question 2

The attempts at drawing diagrams to explain double slit interference in Part (a) were acceptable. Candidates however often lost marks for labelling the superposition of two troughs with an X indicating destructive interference. Some candidates also confused diffraction with refraction and talked about the bending of the waves rather than the "spreading" as they went through a small aperture.

Part (b) proved to be more challenging: candidates were expected to use interference formula $a \sin\theta = n\lambda$ to find the position of the first maximum ($n = 1$) and second minimum ($n = 3/2$) of an interference pattern but very few of them gained full marks. Some could not even get as far as calculating the wavelength of the radio waves correctly because they thought the velocity was 340 m/s.

Question 3

Sometimes candidates learn a formula without having any understanding of its meaning. A glaring example occurred in Part (b) where a significant number of candidates wrote $T = 2\pi\sqrt{L/g}$ to calculate the tension T . In fact the answers to this part of the question were poor even by those who did not make this faux pas: many candidates ignored the centripetal motion and stated that the tension was equal to mg . They were however able to gain marks in the other sections since the examiners, as usual, applied the principle of "error carried forward".

To compensate the responses in Part (a) were good though there were some candidates unfamiliar with the graph for the stretching of rubber.

Question 4

Questions on errors and uncertainty in past examinations were very poorly done so the examiners were pleased to see the number of good attempts this time around: there were a large number of candidates able to score 10 or more marks out of 15.

Most candidates were able to distinguish between precision and accuracy in measurements but the examples they gave could have been better and reflected a ‘practical’ rather than theoretical approach.

Probably the easiest way to estimate the uncertainty in the specific latent heat in (c) is to add together the percentage errors in the three measurements. Candidates who did this (and did not make a careless error in dealing with the 10^{-3} kg) usually gained full marks. The traditional method of writing an equation relating fractional errors was utilised by some but required more care and often gave rise to mistakes in the calculations.

Candidates were not penalised for using the method of finding the maximum possible L value and the minimum value if they did it successfully. Unfortunately however most of them thought that combining the maximum values of the three quantities would give the maximum L which is not true.

Question 5

In Part (a) the wave diagrams showing refraction of water waves in a ripple tank were very poor in the majority of cases and the marks for this section were low.

In Part (b) though most candidates were able to read off values to find the frequency change in (i) some thought they could take a short cut and find the difference in wavelengths and use this for calculating the difference in frequencies.

In Part (ii) required candidates to be able to manipulate an equation to plot a straight line. Obviously this skill needs much more attention since few candidates were able to plot the correct graph and find the value of k from the gradient.

Question 6

Part (a) tested candidates understanding of the equation for thermal conduction. Some candidates found difficulty from the start since they did not relate P the rate of conduction to Q/t in their version of the formula.

Marks were lost in (ii) by candidates who only read approximate values from the graph and in (iii) by those who wrongly assumed that the gradient of the graph was equal to the thermal conductivity. The number of sketch graphs submitted for (iv) which were linear surprised the examiners – surely the similarity to Boyle’s law which they had studied since CSEC level would have precluded this error.

In Part (b) the last part of the question required the use of Stefan’s law but few candidates realised this and those few were often unable to handle the calculations so the scores were quite low.

UNIT 2**PAPER 1****(MULTIPLE CHOICE)****Module 1**

Manipulation of the formula for resistivity and calculation of the current in a series/parallel combination of resistors caused some problems but otherwise the items in this module were well answered. The examiners were particularly pleased with improved performance on questions on the topics of electrostatics and magnetism.

Module 2

Two items about r.m.s. values for a.c. quantities and one on the op. amp. comparator received the poorest responses in the A.C. Theory and Electronics module (less than 30 per cent of candidates answering them correctly).

This year the overall performance on the electronics questions was better than in previous years particularly on those about digital electronics.

Module 3

Most candidates scored best on this module. They demonstrated a good grasp of concepts in radioactivity and atomic structure. However there were two very weak areas: use and understanding of the photoelectric equation and the calculation of binding energy per nucleon.

UNIT 2**PAPER 02**Question 1

Though there were many good answers to this question teachers need to be aware of some common weaknesses running through the marked scripts

In Part (b)(ii) inability to convert cm^2 to m^2 .

Failure to recognise that the maximum value of a sine or cosine is 1

Omission of the number of turns in the e.m.f. calculation

In Part (iii) doubling the frequency doubles the peak e.m.f.

In Part (iv) to investigate changing the area of the coil the other factors must be kept constant.

Question 2

In Part (a) perhaps because of lack of exposure to practical work few candidates knew that a potential divider would be needed to vary the input potential of the operational amplifier and those that did could not connect it correctly.

Some errors occurred in the plotting of the amplifier characteristic that would not be expected at this level: plotting of rounded off values rather than the ones given; freehand drawing of straight lines; use of two table values rather than the best fitting line for the gradient.

It was also noted that many candidates did not use their graphs to find the maximum input voltages but tried to use the table instead.

Question 3

This question elicited a wide range of responses with a pleasing number of candidates able to score 14 or 15 marks. The areas which posed difficulties for some were:

writing (and plotting) $1/8$ with only *one or two* significant figures
 converting nm to metres incorrectly.
 inability to manipulate the photoelectric equation to obtain the equation of the graph
 determining Planck's constant from the gradient.

Question 4

In Part (a) the experiment descriptions were often poor with some not even mentioning how the temperature could be measured. The circuit diagrams submitted were good for the most part though some had ammeters in parallel and voltmeters in series. Some candidates attempted, without success, to use Wheatstone bridge circuits.

Although candidates confused the *potential at Q* with the p.d. across the $5\text{ k}\Omega$ resistor they were still generally able to determine the balance temperature for the thermistor. But some candidates assumed the potential at p was 0 V and said the temperature was $100\text{ }^\circ\text{C}$.

In Part (b) this simplified Kirchhoff's laws problem was generally very well done.

Question 5

Many candidates could only gain marks for the truth tables of the NOR and NAND gates in (a). It seems that in some schools the other parts of the new syllabus such as the replacement of a NAND gate with 4 NOR gates had not been studied.

Part (b) tested candidates' knowledge of adders and half-adders. This is not an easy topic especially if suitable apparatus for constructing the circuits is not available in the school. Responses such as "*The half-adder is used to add 2-bit binary numbers while the full-adder is used to add 3-bit binary numbers*" showed that teachers need to go back to basics when teaching this topic: starting with adding numbers together on paper and understanding the concept of "carrying" to the next column. In the last part of the question some candidates merely used two half adders to make a full adder failing to recognise that an OR gate was needed too. Surprisingly many of them went on to describe an application rather than giving an example to explain its *operation*.

Question 6

There were more low scores on this question than on any other in the paper. It appeared that candidates were not prepared for this part of the syllabus.

Millikan, as part of his methodology, determined the mass of an oil drop accurately: he then tried to preserve this oil drop and measure several times the charge it could acquire. To change the charge he used X-rays (particles could also have been used). Candidates confused this changing of the charge on a particular oil drop with the initial charging of oil drops as they emerged from an atomizer.

Thoughtless errors such as using g rather than mg for weight, poor manipulation of powers of ten and poor recall of Newton's 2nd law caused the scores in Parts (b) and (c) to be low even for those who had studied this topic.

CARIBBEAN EXAMINATIONS COUNCIL

**REPORT ON CANDIDATES' WORK IN THE
CARIBBEAN ADVANCED PROFICIENCY EXAMINATION
MAY/JUNE 2008**

**PHYSICS
(REGION EXCLUDING TRINIDAD AND TOBAGO)**

PHYSICS

CARIBBEAN ADVANCED PROFICIENCY EXAMINATION

MAY/JUNE 2008

GENERAL COMMENTS

The performance of candidates in the 2008 examination was similar to that of 2007 with the mean score of the Multiple Choice papers significantly higher than that on the written papers.

The examiners see the need for candidates to gain more experience in problem solving and in analysis and interpretation of graph data. In the latter case, they would like to emphasise the syllabus' call for four or five practical exercises to be performed in each module, including some experiments which test hypotheses.

DETAILED COMMENTS

PAPER 01

Multiple Choice

There were several items in which candidates showed poor reasoning skills and could not select the best response.

Module 1

1. Less than 30 per cent of candidates knew that if $xy = \text{constant}$ and graph of y against x would be a curve. Most thought it would be a straight line through the origin.
2. Few candidates could work out how gravitational field strength 'g' would vary with height above the Earth's surface.
3. There were instances when candidates were tempted into choosing options for which quantities which they should know are constant changes, for example, the acceleration due to gravity at the Earth's surface, or the work done on various masses when a constant force moves through the same distance.

Module 2

4. The formula for the period of a mass on a spring is $T = 2\pi \sqrt{\frac{m}{k}}$: it does not depend on the value of g . But more than 80 per cent of candidates thought it did.
5. When students learn a formula it is essential that they also understand all of the terms. In the interference equation $\frac{\lambda}{\alpha} = \frac{x}{D}$, X is the fringe spacing, that is, the distance between two adjacent fringes and should not be confused with the total width of the pattern.
6. The relationship between the number of lines per metre and the spacing of the lines in a diffraction grating was poorly understood by a majority of candidates.

Module 3

7. Candidates ought to realise that in a composite thermal conductor the largest temperature difference occurs across the portions with the lowest conductivity. In this exam most of them opted for the opposite conclusion.
8. Confusion between the molar value and molecular value of the kinetic energy of a gas caused about half of the candidates to choose the wrong response for any item on this topic.
9. Few candidates knew the meaning of the term “isothermal”.

Unit 1**PAPER 02****Section A**Question 1

The graph in this terminal velocity question was drawn competently by the majority of candidates but the explanation of its shape which followed was often poor, many candidates gave a description rather than an explanation. A good answer would have mentioned that the acceleration was decreasing as the resistance to motion increased as the sphere moved faster.

Many candidates were able to successfully calculate the mean acceleration by using the graph to find the change of velocity and dividing by the time interval. Those who tried to estimate the gradient were less successful.

In Part (b) the inability to manipulate the formula was the downfall of a significant percentage of candidates. (Mean score 8.2/15)

Question 2

Some of the responses to Part (a) were rather vague and did not contain much physics. The examiners were expecting candidates to know that a standing wave is set up on a guitar string and that this vibration then causes a longitudinal sound wave to be transmitted through the air to the air.

The first two sections of Part (b) were fairly well understood but in Part (b) (iii) candidates struggled, with many candidates not knowing how to set out a (mathematical) derivation.

Having been given the relevant formula candidates were expected in Part (c) to find the velocity of the wave from the gradient ($= v/2L$) of a graph but most candidates, though able to plot the graph were, disappointingly, unable to make any further headway. (Mean score 7.1/15)

Question 3

The mean score on this thermometer question was significantly lower than the other questions in Section A, only a minority of candidates seemed to have understood the principle of the use of a constant-volume thermometer. Indeed, very few candidates even knew how to achieve a constant volume of gas by adjusting the height of the mercury. Instead they talked about avoiding leaks in the glass bulb or the rubber tube.

The attempts at calculating the pressure of the gas Part (c) were also very disappointing, the minority of candidates who used $p = \rho gh$ either forgot to add on the atmospheric pressure or simply added 76 to the answer in pascals! (Mean score 4.6/15)

Section B

For all of the questions in Section B, candidates' responses were generally poor, seeming to indicate a lack of preparation for this type of free-response question. Each question required first demonstration of knowledge of a key topic in the respective module but candidates' writing and explanations were so poor that they gained few marks. The application of basic principles to the solution of numerical problems was not much better and the scores in the second part of these questions were also low. Perhaps candidates need to be reminded that they must practise doing these longer questions during their revision rather than merely reading their notes or text books and hoping it will all work out in the exam.

Question 4

In Part (a), candidates were expected to show an understanding of the vector nature of the quantities involved in circular motion, the velocity changes directions and so are not constant and no work is done by the centripetal force since there is no displacement in the direction of the force. Many candidates gained marks only for the formula in Part (a) (ii).

Some candidates confused the conical pendulum in Part (b) with the simple pendulum and wrote $T = 2\pi \sqrt{L/g}$ and then proceeded to interpret T as the tension in the string! Others did not recognise that there were only two forces acting, the weight and the tension and found difficulty proceeding. There were only a few better candidates who were able to resolve the forces successfully and calculate the tension in the string and the speed of the mass.

Most candidates recognised that if the string breaks the mass will fall to the ground as a projectile. However, only a minority were able to see that the initial vertical velocity would be zero and that the time of fall could be calculated from $s = \frac{1}{2}at^2$. (Mean score 2.3/15)

Question 5

The principle of the diffraction grating is that each fine slit, by diffraction, becomes the source of light waves which then interfere with waves from the other slits to produce spectra. Though there were some good responses to Part (a), often candidates' discussion of this principle was sketchy and many candidates did not produce the required wave diagrams to show their understanding of *diffraction* and *interference*.

The calculations in Part (b) were generally poorly done. The most common error being the substitution of the number of lines per metre for the value of a in the formula $a \sin \theta = n\lambda$.

(Mean score 3.3/15)

Question 6

In spite of Rumford's historic experiments, the caloric theory still lives on the minds of this year's CAPE candidates. No matter how many times their teachers must have told them that "heat" is not a thing but, like work, a description of a way of transferring energy, they are still unable to differentiate between Q and ΔU in the first law of thermodynamics. This difficulty in many cases permeated the whole of their response to this question and caused the mean score to be very low.

In Part (b), candidates were generally unfamiliar with the fact that the work done in a cycle may be found from the area enclosed on a p-V diagram. The use of the gas law in (ii) was much better but few candidates were able to use the molar heat capacities to find the energy added as heat and hence the efficiency. (Mean score 3.1/15)

Unit 2**PAPER 01/Multiple Choice**

The paper was well designed and did not pose too many problems for a candidate who was well prepared for the exam.

Module 1Question 1

In Module 1, only two of the fifteen questions had a high number of incorrect responses associated with a particular key.

Question 14: 33 per cent of the candidates chose Key B instead of Key D, because they chose the ratio as 1 : 8000 instead of 1800 : 1 even though it was clearly stated in the stem of the question what was required.

Question 6: 45 per cent of the candidates chose Key B instead of Key C from a question based on the unit of permittivity. They were unfamiliar with the physical quantity permittivity and could not deduce $C^2 N^{-1} m^{-2}$ as the correct response; the majority chose $N m^{-2} C^{-1}$

Module 2

Most of the questions in this module carried a diagram which the students had to interpret in order to choose the correct key. Only one of the questions in this module had a large number of incorrect responses. The use of a potential divider seems not to be clearly understood.

Questions involving logic gates were well done with many correct responses (constructing Truth tables is always an easy task), while questions on the op-amps obviously proved to be more challenging and requires a lot more thought and application of knowledge.

Module 3

The most challenging questions in Module 3 were both on Millikan's oil drop experiment. The concept of a charged oil drop and quantization of charge is not clearly understood. Perhaps this experiment is too difficult to visualize and few students have even done this experiment.

Unit 2**PAPER 02****Section A**Question 1

This question tested candidates' understanding of the standard technique for dealing with exponential data, that is, the use of linear natural log graph. Though few candidates used irregular scales or scales made too small by the inclusion of the origin, the plotting was for the most part quite satisfactory. However, the overall scores on this question were low due to poor interpretation of the significance of the intercept and gradient of the graph.

In Part (d), candidates were expected to see that the voltage would fall from the 3 v provided by the battery in the same exponential manner as the current. This proved to be surprisingly challenging. (Mean score 5.7/15)

Question 2

This question was mainly about the implementation of logic circuits using NAND gates. Many candidates seemed not to have studied this topic and could make little progress.

For some candidates the only marks gained would have been for the Truth table in Part (b) and perhaps the drawing of the flip-flop in Part (c). Even those who could draw the NAND bistable often showed little understanding of its operation. (Mean score 5.7/15)

Question 3

The current in a photocell remains constant once the voltage is sufficient to attract all of the produced electrons to the anode, further increases in the p.d. can have no effect on the current. This principle was not familiar to most candidates but they scored well on the other parts of Part (a).

In Part (b), the graph plotting was fine but again the extraction of values from the graph was very poorly done. (Mean score 6.4/15)

Question 4

Though Lenz's law was known by almost all the candidates, its application to the "jumping ring" demonstration proved to be beyond all but a few. Even those candidates who did explain that an induced current in the ring would cause a field which opposed the field in the iron core could not take the argument further to say that a slot cut in the ring would prevent current flow and hence the ring would no longer jump.

Most candidates knew that flux was defined by the equation $\phi = BA$ but they forgot to multiply by the number of turns when calculating the total flux through the coil in Part (c). Although the examiners applied "error carried forward" in the remainder of Part (c) the marks were still mediocre as candidates failed to recognise the fact that the maximum value to the e.m.f. offered when the sine of the angle was equal to 1. (Mean score 3.5/15)

Question 5

Imprecision caused candidates to lose credit in Part (a). Only the better candidates used Kirchoff's law correctly at Point X in the op.amp. circuit and then stated that $I_1 = I_2$ since I_3 would be zero if one assumed the op.amp. had infinite input impedance. Many candidates carelessly wrote $I_1 = I_2$. Later in their derivations they would "fudge" another incorrect sign to obtain the required answer.

Only a few candidates plotted the required *suitable graph* in Part (b) – the examiners expected candidates to be familiar with the standard techniques of data analysis at this stage in their physics education but were sorely disappointed. Perhaps teachers need to provide more exercises in the laboratory which involve plotting *linear* graphs to test hypotheses – candidates should not be plotting curves from raw data and then concluding, by inspection, that the relationship is true because "R goes up when A goes down". (Mean score 5.3/15)

Question 6

There were some good attempts at dealing with the concept of binding energy in Part (a) though the last part proved difficult since candidates did not picture Helium-4 as an alpha-particle which could be emitted whole in a radioactive decay.

The radioactive decay equation for radon in Part (i) was understood by most candidates and the attempts in Part (ii) to find the number of atoms present were creditable though tended to lose marks through careless calculations. However, Part (iii) confused most candidates, they knew that power was energy divided by time but the time they used was the half-life! Only the more thoughtful noticed that every decay would release 6.3 MeV ($= 1.06 \times 10^{-12}$ J) and so they merely had to multiply by the number of decays per second. (Mean score 4.2/15)

CARIBBEAN EXAMINATIONS COUNCIL

**REPORT ON CANDIDATES' WORK IN THE
CARIBBEAN ADVANCED PROFICIENCY EXAMINATION**

MAY/JUNE 2009

PHYSICS

PHYSICS**CARIBBEAN ADVANCED PROFICIENCY EXAMINATION****MAY/JUNE 2009****GENERAL COMMENTS**

The number of candidates for CAPE Physics in 2009 increased for Unit 1 from 2527 to 2970 and decreased for Unit 2 from 1855 to 1783.

Some areas of poor performance were:

- Newton's laws of motion and their application
- Simple Harmonic Motion
- The explanation of the First Law of Thermodynamics

DETAILED COMMENTS**UNIT 1****Paper 01****Module 1**

Candidates found difficulty with:

- Question 6 – which tested the equations of motion and their application
- Question 12 – which tested satellites in orbit

Module 2

Candidates found difficulty with:

- Question 20 – which tested the representation and interpretation of transverse wave motion on a graph.
- Question 23 – which tested the representation and interpretation of standing wave motion in a graph.

Module 3

Candidates found difficulty with:

- Question 36 – which tested the movement of heat through an insulated composite metal rod.
- Question 37 – which tested the application of Stefan's Law in heat radiation with respect to a large blackened metal cube.
- Question 41 – which tested the application of the first law of thermodynamics to an isothermal process.

- Question 43 – which tested the molecular model of liquids.
- Question 44 – which tested the interpretation of information from a force-extension graph.
- Question 45 – which tested the calculation of the work done from a force-extension graph .

UNIT 1

Paper 01

Question 1

This question was intended to test candidates' understanding of 'momentum' and 'impulse of a force' and to relate the two quantities by analysis of a graph. Parts (b) (i), (iii) and (c) (i) were basic and elementary, affording every candidate the opportunity to score a minimum of 6 marks. It was not unusual for candidates to write the equation required for (a) (i) using symbols other than those given, simply because they could not define 'impulse' as Fxt and relate it to change in momentum. Some candidates failed to recognise that the line to be drawn in (c) (ii) could be drawn from the coordinates (0, 17.6) and (5.6, 3.9) derived from the answers to Part (b) of the question. Few candidates correctly analysed the graphs to obtain answers for Parts (c) (iv) and (v).

Question 2

Simple Harmonic Motion (S.H.M.) as it applies to the depth of water at a harbour as the tide changes was the emphasis in this question.

Part (a) merely tested if the candidates really understood what is Simple Harmonic Motion. It was disappointing to see how few candidates could state the criteria required for a system to be performing S.H.M.

In Part (b), a number of candidates misinterpreted the graph of variation of depth of water in the harbour with time, and treated it as a portrayal of a wave in the sea. It was a sketch graph, not drawn to scale. Candidates should be encouraged to use very specific language or expressions when giving word responses. Too many vague descriptions were used in describing the procedure in Part (b). This is a planning and design skill in the SBAs.

Many candidates performed poorly in Part (c) (i) and (ii). Their mathematical skills failed them. ' $\omega\tau$ ' is the angle of the function and cannot be separated into $\sin \omega$ and τ . The calculator needed to be in the **radian** mode rather than degree mode, to obtain the following answers:

c (i) 4m; c (ii) 1 hour, 5 hours; c (iii) 4 hours.

Question 3

This question focused on Specific Objective 1.5 of Module 3.

Candidates were able to apply the equation for the 'empirical scale' in Part (a). Precisely what was being asked in (b) (i) was not clear to the average student and so the question did not yield the type of responses expected by the examiner. All that was needed was a statement suggesting 'to agree with old Celsius scale'.

In Part (c) it was instructed that the P_{tr} scale should start at 0, because in Part (e) the intercept had to be read off. Candidates seemed not to appreciate the reasoning for this and proceeded to start both scales from zero. The range of data for P_t/P_{tr} was too small for a proper graph to be plotted starting P_t P_{tr} axis from zero. The graph plotting skills, which should be developed in the SBAs, left a lot to be desired in this question. It must be emphasised that the accurate relationship between Celsius and Kelvin is $0^\circ\text{C} = T_k - 273.15$ and **not** 273.16.

Paper 2

Question 4

Part (a) (i) of this question was done the worst. All the definitions were in general poorly stated. ‘Kinetic energy’ being the best done and ‘energy’ the worst. It was surprising that candidates who scored high marks in this question could not define energy as ‘the capacity to do work’. Even though a number of candidates could define kinetic energy, too many candidates gave vague or incorrect responses such as ‘energy in motion’, ‘moving energy’, etc. Many candidates confused gravitational potential energy with gravitational potential.

In Part (a) (ii) candidates were in general not sequential in their proof for kinetic energy and omitted steps.

For Part (b) (ii), instead of determining the velocity by equating kinetic energy to gravitational potential energy, attempts were made at using the equation. $v^2 = u^2 + 2as$. Using $v=r\omega$ to solve for ω was done by many candidates, but the weaker students attempted to use $a=r\omega^2$ and substituted $a=9.81\text{ms}^{-2}$. The centripetal force was not understood to be the resultant of the tension and the weight and therefore should not have been included in the free body diagram. In order to determine the

tension, many candidates correctly used $(T = mg + \frac{mv^2}{r})$, but some of the weaker candidates even

attempted to use $T = 2\pi \sqrt{\frac{l}{g}}$.

Question 5

This question was intended to test the use of the formula $\frac{1}{f} = \frac{1}{u} + \frac{1}{v}$ as it applies to the human eye in correcting eye defects. Most candidates had a reasonable idea of ‘accommodation’ but very few candidates could distinguish between ‘depth of focus’ – the distance or range within which images seem to be in focus and the term ‘depth of field’ which applies to a range of object distances. Some treated these terms as being synonymous. It was easy to identify the eye defect as long-sight and know that it can be corrected with the use of a convex lens, but to illustrate this with a ray diagram

proved to be difficult. The need to use the formula $\frac{1}{f} = \frac{1}{u} + \frac{1}{v}$ to solve (c) (i), (ii) and (iii) was easily recognised, but many candidates failed to apply the sign convention correctly to the appropriate object and image distances. Another downfall was not knowing that a power of 2.0 D applies to a lens of focal length 0.5 m (or 50 cm) in the S.I. system. Correct calculations gave answers: c (i) 50 cm, (c) (ii) 200 cm; c (iii) 3.5 D.

Question 6

This question tested candidates' ability to state and use some equations in Thermodynamics. There was no doubt that candidates had met equations like $\Delta\mu = Q + W$; $C_p - C_v = R$; $PV = nRT$; $Q = nC_v \Delta T$ and $W = P \Delta V$, but making an accurate statement for **each** symbol caused problems. Expressions such as 'work done **by**' and 'work done **on**' need to be clarified. Candidates lost marks carelessly: not changing the subject on an equation correctly; incorrect read-offs from the graph: these were two of the popular mistakes. Candidates at this level should show a greater appreciation for significant figures and avoid stating final answers to numerous figures when the data provided is only quoted to a few significant figures.

UNIT 2**Paper 01**

Candidates scored well on the questions on this paper.

Paper 02Question 1

The topic on I – V characteristics is well known by most, but at this level candidates are expected to be familiar with the use of the potential divider circuit used to examine I - V characteristics. They need also to understand the advantage of using the potential divider instead of putting a rheostat in series with the ammeter and the diode.

Part (c) involved some mathematics with a logarithmic equation, which proved to be a problem for some candidates. Candidates must not shy away from these mathematical techniques which are part of the Physics course. Please refer to the syllabus under "Mathematical Requirements".

Answers: $n = 1.5$; $k = 5 \times 10^{-3}$

Question 2

There were some good attempts at this question.

Parts (a) (i) and (ii), could be answered by most candidates.

In Part (a) (iii), candidates had a good theoretical knowledge for constructing the NAND gate with the NOR gates, but failed to apply it practically in the QUAD NOR gate diagram, by making the correct connections.

In Part (b) (ii), completing the truth table was easy, but a surprising number of candidates could not use the output from the table to deduce the answer for Part (b) (iii) and simply say 'the lamp will burn when A and B have different states'.

In Part (c) (iv), difficulty was again experienced in constructing the EX-OR gate using a combination of NAND gates. Perhaps greater emphasis could be placed on equivalence relationships using NAND and NOR gates.

Question 3

This question required a good understanding of the quantities in the photoelectric emission equations $hf = \Phi + \frac{1}{2}mv^2$ and $hf = \Phi + eV_s$ and the ability to use them appropriately. The majority of candidates knew that h is the symbol for Planck's constant, but there was a variety of misconceptions expressed for the other symbols, hence the difficulty in sketching the graph for Part (a) (ii) and clearly identifying the stopping potential, V_s . Again, lack of knowledge and clear understanding of the symbols in the formulae was reflected in Part (b) (iii). The gradient of the graph is $\frac{h}{e}$ and not h ; intercept of the frequency axis is the threshold frequency. The nature of the question was such that 4 marks could have been scored for plotting the graph without any sound knowledge of the topic of photoelectric emission.

Question 4

The responses to this question suggest that candidates are not spending enough time trying to comprehend well enough to be able to explain and apply concepts.

Part (a) was testing a recall of knowledge on magnetic fields and electromagnetic induction, and many were unable to express their thoughts with any degree of clarity. It was obvious that they had done

the topics, but failed to make an accurate recall of the formulae $B = \frac{\mu_0 I}{2\pi r}$, $B = \frac{\mu_0}{2r} NI$, $B = \mu_0 nI$ as listed in the syllabus.

Which formulae are to be applied and when, caused problems. Some candidates could not distinguish between n and N , hence they juggled with the numerical data given in an attempt to gain marks in Part (b). Those who knew and understood what the symbols in the equations represented easily gained marks in the calculations.

Answers (b) $12.6 \times 10^{-3} \text{ T}$; $1.58 \times 10^{-5} \text{ Wb}$; 15.1 mV .

Question 5

The objectives tested were well within the syllabus. However, it was amazing to see the number of candidates who either did not, or could not, determine the frequency of a waveform having been given its period, as in Part (c) (i). Based on the responses, candidates appeared not to be familiar enough with the specific objectives of the syllabus on operational amplifiers. Far too many candidates failed to see that the graph in Fig. 6 is a logarithmic graph and as such the actual frequency between 1 and 10, 10 and 10^2 etc. is not on a linear scale. It was disappointing to see how many candidates at this level did not convert ms to s correctly. In Part (c), although candidates recognised that 'clipping' would have occurred at 15V, the failure to apply this by the flattening of the graph for the output voltage was obvious.

Question 6

This Radioactivity question was not so well done by many candidates. The definition of 'half life' was the only thing that allowed some candidates to get a single mark. There were some candidates however who were able to score full marks and presented their responses in clear logical steps. As occurred in some of the earlier questions, the mathematics caused a problem. Correct use of SI Units and simple conversions like hours to seconds should not be a problem at this level.

Part (c) was not readily comprehended and was worth 5 marks, so that candidates scoring less than 10 marks surely lost their marks in Part (c).

Answers: (b) (i) $12.8 \times 10^{-6} \text{ s}^{-1}$; (ii) 2.51×10^{19} atoms; (iii) $3.21 \times 10^{14} \text{ Bq}$
(c) 6000 cm^3

Paper 03/2 - (Alternative to Internal Assessment)

Fourteen candidates wrote this paper which was offered for the first time this year. Candidates' responses revealed that they were not well prepared for this paper. The mean for this paper was 21.43 out of 48 and the range was 7 – 34. It is expected that as the offering of this paper becomes widely known more candidates will opt to write this paper and performance will increase.

CARIBBEAN EXAMINATIONS COUNCIL

**REPORT ON CANDIDATES' WORK IN THE
ADVANCED PROFICIENCY EXAMINATION**

MAY/JUNE 2010

PHYSICS

GENERAL COMMENTS

The number of candidates registered for CAPE Physics in 2010 increased from 2790 to 2999 and 1795 to 2330 for Units 1 and 2 respectively. For Unit 1, ninety-one per cent of the candidates earned Grades I – III and for Unit 2, eighty-two per cent of the candidates earned Grades I – III.

Some areas of poor performance were:

- Newton's laws of motion and their application
- Simple Harmonic Motion
- The explanation of the First Law of Thermodynamics

DETAILED COMMENTS

UNIT 1

Paper 02 – Structured Questions and Essay Questions

Question 1

Part (a) (i) was easy and straightforward and most candidates were able to plot the graph.

Part (a) (ii) required candidates to describe 'qualitatively'; it was expected that they would recognize that the ball rolled down the plane with uniform acceleration, collided with the block and rebounded up the plane, eventually coming to rest. In Part (a) (iii), the instruction given was to 'calculate', but it was expected that the graph would be used to determine the answers by working out the gradient and area under the graph. A few candidates recognized that the force was related to Newton's second Law:

$$F = \frac{mv - mu}{t}$$

Teachers should remember to emphasize that energy is conserved during an elastic collision.

Answer: a (iii) 3.5 m s^{-2} ; 2.5 m; 91.2N

Question 2

In Part (a), candidates failed to draw rays of light through a rectangular block and a triangular prism correctly. Very few were able to show what happens with white light as it passes through a diffraction grating. In Part (b) (ii), the majority of candidates were able to recognize the action of 'total internal reflection'. Too many candidates complicated matters because they learnt the formula $n = \frac{\sin \theta_1}{\sin \theta_2}$ or $n = \frac{\sin i}{\sin r}$, without a clear understanding of its use. When teaching this topic, teachers should be sure to emphasise what is meant by the *refractive index* of a medium like glass:

$$n_{\text{air}} n_{\text{glass}} = \frac{\sin \theta_{\text{air}}}{\sin \theta_{\text{glass}}} \quad \text{or} \quad n_1 \sin \theta_1 = n_2 \sin \theta_2$$

The ability to read off values from the graph scales to fill in the table and to determine the gradient seemed a difficult task for some candidates.

Answer: (b) (iii) 1.45

Question 3

All candidates seemed familiar with this topic relating to Young's modulus. It was easy for them to gain a few marks from Part (a) for defining the terms 'stress' and 'strain', and sketching at least one of the graphs correctly. It was disappointing to see that many candidates could not fill in the missing values of Extension, $\Delta L/m$ correctly. In addition, there were those candidates who knew how to calculate the extension but ignored the units given in the table. Almost every candidate could recall Young's modulus = $\frac{\text{stress}}{\text{strain}}$. However, getting past there to Part (iii) $E = \frac{MgL}{A\Delta L}$ and Part (iv) $E = \text{gradient} \times \frac{gL}{A}$ proved to be difficult for many.

Answer: (b) (iv) $1.82 \times 10^6 \text{ Nm}^{-2}$

Question 4

It was surprising that many candidates could not answer Part (a) which required that they express the ideas that 'resultant force must be zero' and 'the resultant torque must be zero'. Instead, candidates wrote about 'upward forces being equal to downward forces' as if forces only act in a vertical plane.

Part (b) tested candidates' understanding of the vector nature of velocity; many candidates failed to apply a sign convention, so that even though they knew the equations of motion, they failed to apply them correctly to the given situation. At this level, candidates should be exposed to a wider range of examples on this topic especially involving motion in a vertical plane under the influence of gravity.

Answers: (a) (ii) 167N, 73N; (b) (i) 1.5 m s^{-1} , 0.55 m s^{-1} (b) (ii) 0.735 (b) (iii) 1.1 m

Question 5

Teachers need to define clearly for students the threshold of hearing and threshold of pain. For Part (a) (i), many candidates defined those terms as a range of frequencies or as a point rather than a specific intensity.

Most candidates were not aware that the answer for Part (a) (ii) was that *the ear responds to a wide range of intensities of sound* or that *the ear's response to sound intensity is logarithmic*. Many candidates also misinterpreted the phrase 'property of the ear' to mean 'a physical feature of the ear'.

In Part (a) (iii), many candidates did not know the expression $\beta = 10 \log_{10} (I/I_0)$. Some were not able to write \log_{10} and instead wrote $\log 10$ which is, of course, incorrect. Others wrote 1 as the subject of the equation instead of β .

For Part (a) (iv), several candidates did not recognize 3.82 mWm^{-2} as $3.82 \times 10^{-3} \text{ Wm}^{-2}$, where the first m in the unit was the prefix milli = 10^{-3} .

Part (a) (v) was fairly well answered. Most candidates understood that there would be a reduced ability to hear frequencies and that the audible range of frequencies will decrease especially at the upper end. However, they did not recognize that the threshold of hearing would increase, not decrease, since the intensity that you would need to hear a particular frequency would increase. There were candidates who did not know that 10^{-8} was greater than 10^{-12} . Candidates misused frequency for intensity.

In Part (b) (i), the majority of candidates did not recognize that upon reflection that the reflected sound would have a smaller amplitude than the incident sound wave due to loss of energy and hence upon destructive interference, the wave would not completely cancel out. Some candidates did not recognize that the destructive interference is caused by the interaction between the incident wave and the reflected wave and not interference between the incident wavefronts.

For Part (b) (ii), a fair number of candidates calculated λ and subsequently the frequency, f , based on their interpretation of the diagram drawn in the question. However, there were some candidates who were not able to calculate λ . Some candidates did not even know the formula $v = f\lambda$. Many used λ as 2.25m.

In Part (b) (iii), the vast majority of candidates calculated λ correctly but were not able to go on and determine the distance from the wall. They did not recognize that there was a node at the wall and that the distance between the node (which occurred at the wall) and the next node was $\lambda/2 = 1$ m and hence the maxima in between would be $\lambda/4 = 2/4 = 0.5$ m from the wall.

Answer: (a) (iii) 96dB

Question 6

The examiners were dismayed by the number of candidates who could not use their knowledge of the transfer of energy by radiation to give an adequate explanation of the greenhouse effect in Part (a).

The conduction of heat through the walls of a stove and the subsequent loss of this energy to the surroundings was the subject of calculations in Part (b). The majority of candidates had little difficulty calculating the rate of conduction, 277 kW, and scored well.

Few candidates scored more than one or two marks for the remainder of Part (b). Even though candidates were able to write the equation for Stefan's law, they were unable in most cases, to use it: they either selected the wrong temperatures or failed to convert correctly to Kelvins. Only the very best candidates obtained the correct answer of 185 kW.

Part (b) (iii) seemed to be misunderstood. It was expected that candidates would see that the rate of radiation away from the stove was 92 kW less than the rate of conduction to the outside of the stove and that this difference must be accounted for by conduction to the surrounding air and subsequent convection currents.

Paper 03/2 – Alternative to Internal Assessment

This was the second year that this paper was offered. Seven candidates wrote Unit 1 and six wrote Unit 2. Unfortunately, there was no improvement when compared with 2009. The responses were poor and again supervisors failed to submit the required information needed by the examiner to assist with the marking. Entries were from three different centres and only one of these centres submitted a Supervisor's Report.

UNIT 2

Paper 02 – Structured Questions and Essay Questions

Question 1

Candidates found it relatively easy to score more than half of the mark on this question. Once they had studied the topic on capacitors in the syllabus, it was easy to apply the formulae to Parts (a) (i) and (a) (ii) even if the definition for capacitance was not accurately stated. Part (b) involved taking data from one graph and completing a table to plot another graph. This task could be carried out with any knowledge of capacitors. Where candidates fell down, however, was in making the conclusion in Part (b) (ii). Every Physics student should be able to make a conclusion such as ‘ y is directly proportional to x if the graph is a straight line passing through the origin’.

Answers: (a) (ii) $13 \times 10^{-3} \text{ C}$; (iii) $38 \times 10^{-3} \text{ J}$

Question 2

In Part (a) (i) a), it was not enough to say that p-type materials had positive charge carriers; these carriers had to be identified. Therefore, few candidates could state a p-type material as a semiconductor material in which holes are the majority charge carriers.

For Part (a) (i) b), candidates found it difficult to explain that n-type material has electrons as the majority charge carriers.

For Part (a) (i) c), many candidates were not aware that the depletion region is an area where there are no charge carriers, that is, it is devoid of charge carriers.

With regard to the diagram of a junction transistor, Part (a) (ii) was poorly done. Many candidates were not able to correctly draw the diagram along with the corresponding symbol for it.

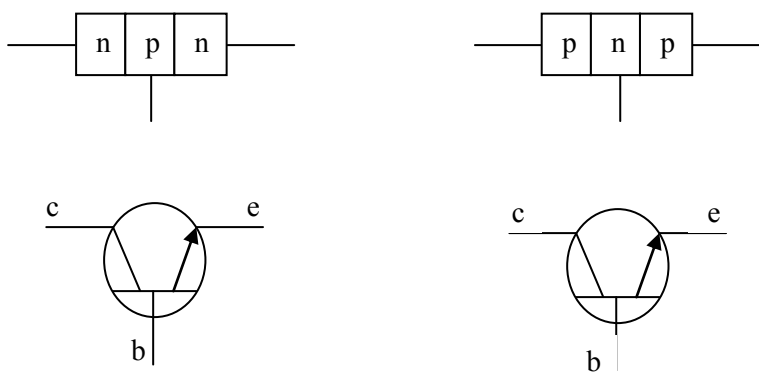

Many candidates drew the diagram incorrectly with no connections, for example:

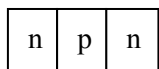

Most candidates drew the symbol for the semiconductor diode instead of the transistor and some candidates did not place the arrow on the emitter for the symbol.

The majority of candidates completed the table correctly in Part (b) (i). However, some of them did not know how to find the \ln of numbers, while others converted the values of $\ln \mu\text{A}$ to Amperes and then tried finding \ln , hence getting negative values for the table.

In Part (b) (ii), the majority of candidates were able to plot the graph, however, the major problem with the graph was the choosing of an appropriate scale for the axes. Teachers need to focus on this aspect of graph plotting with their students and also on the drawing of the line of best fit.

Some candidates plotted V against $\ln I$, showing clearly that they were not aware as to which variable goes on which axis.

There were candidates who tried to use the power of 10 on the axes to convert the decimal to whole numbers but used the wrong power. More care is required when plotting the points since many candidates plotted the last point incorrectly.

Many candidates were able to write the correct equations for Part (b) (iii). However, some of them wrote expression or proportional relationships. Teachers should remind students that equations have an equal sign. More emphasis needs to be placed on showing students how to manipulate terms with natural logs and exponents.

Although some candidates got the correct equation in Part (b) (iv), they were not able to figure out the gradient of the line $m = e/nkt$. They included the variable V in the expression for the gradient. With regard to the calculation of the gradient, most candidates were able to accomplish this, although some candidates were not able to correctly read off one or more of the values from the graph, or took values from the graph or table which were not on the line drawn. Hence, they calculated the wrong value for the gradient.

Of those candidates who were able to recognize the gradient as $m = e/nkt$, some of them were not able to transpose correctly to get $n = e/mkt$. There were candidates who, in calculating the gradient, multiplied the values of $\ln I$ by 10^{-6} in an attempt to convert to Amperes, which was incorrect. They did not recognize that the log of a quantity does not have a unit.

Teachers need to help students to sharpen their algebraic skills so that they are able to gain maximum marks for questions. Some candidates mixed up the natural log with the e , the charge of an electron ($1.6 \times 10^{-19}\text{C}$).

Answer: (b) (iv) 1.4

Question 3

This question focused on the concept of radioactive half-life. Part (a) required candidates to describe how to determine the half-life of a sample of radon-220 gas, whilst Part (b) involved calculations on the decay of the same gas.

A suitable method for finding the half-life of radon-220 is described in the CAPE syllabus on page 62 and in most of the texts used at this level. It was therefore very disappointing to see so many scripts in which candidates scored zero.

The calculations in Part (b) were also poorly done. Far too many candidates abandoned the half-life concept and resorted to using the exponential decay formula: surely the recognition that 108 seconds is two half-life periods and the amount remaining as radon is reduced to one quarter is much simpler. The number of α -particles emitted is then simply the number of atoms in 3 mg of radon-220.

In Part (b) (ii), many candidates used the concept correctly and reduced the activity by a half, n times either ‘long-hand’ or by saying that $\left(\frac{1}{2}\right)^n = \frac{1}{1000}$.

However, those candidates who used the exponential equation made the exercise much longer and were prone to making errors along the way and losing marks.

Question 4

Most candidates were able to state Kirchoffs Laws and the physical principles on which they are based. Beyond this, the weaknesses started to show up. There was difficulty distinguishing between the e.m.f and the p.d of a cell. Part (c), applying Kirchoffs Laws to the network given was a problem for many. Some candidates, after writing the equations correctly, exhibited poor mathematical skills and failed to reach the correct solution. A few of the more able candidates scored full marks on this question.

Answers: (c) (i) 0.5A; (ii) 1A

Question 5

The responses to this question reflected a complete lack of knowledge of the op-amp. Candidates either did not respond to the question or scored zero when they attempted an answer. This suggests that the topic was not taught. Scores in the range 1–4 marks were earned from b (i) – (iii), implying that some attempt might have been made at teaching the topic, but it was not clearly understood by the candidates. This is a serious omission which needs to be corrected.

Answers: (b) (i) 3.0V; (ii) 0.42V

Question 6

The number of candidate who did not respond to this question and the low scores attained by those who responded suggests that this topic was not taught or was inadequately covered. In Part (a), the sketch graph should have been labelled and not left for the examiner to interpret; some of the sketches were very poorly drawn. Part (b) was also on the topic of x-rays. Throughout the entire question, reference was made to x-rays, yet some candidates tried to do the calculations using the formulae associated with photo-electric effect. For many candidates, the only part of the entire question that was attempted was b (i) where they used $P = IV$. This question is a good example of why teachers should emphasize the general approach to questions involving calculations as: step 1, state equations to be used; step 2, substitute values in equation; step 3, state calculated value with unit where applicable. Candidates must not be allowed to juggle with numbers and then state an answer. Instruction 4 on the front page of the question paper reads: All working MUST be CLEARLY shown.

Answers: (b) (i) 60 W; (ii) $1.33 \times 10^8 \text{ m s}^{-1}$; (iii) $24.9 \times 10^{-12} \text{ m}$

Report on Internal Assessment Moderation

The following issues arose out of the moderation exercise.

a) Number of Assessments

There were numerous cases where only two assessments were done for each skill. The moderation team thought that this was inadequate and did not represent an advanced level assessment of the course. The team recognized that this action could have originated from a misinterpretation of a clause in the CAPE Physics Syllabus (p. 67), Specific Guidelines for Teachers #5, which states:

The mark recorded for each skill assessed by practical exercises should be the average of at least two separate assessments.

As a result, many centres submitted two assessments for each skill. In some of these situations, the two exercises did not meet the basic CAPE standards and therefore moderators were hard pressed to find legitimate exercises to moderate.

b) No Assessment of Manipulation and Measurement

In some cases, there was no way of verifying how the manipulation and measurement scores were determined. There was no record of the marks in candidates' books.

c) No Mark Schemes Submitted

The number of cases where mark schemes were not submitted diminished over the previous year. However, there are still some occurrences.

d) Mark Schemes Inadequate for Some Skills

Some centres continue to assess exercises using criteria that do not match the skill, for example, many centres include 'plotting points' as Analysis/Interpretation criteria when it is an Observation/Recording/Reporting skill. Invariably, an inordinate number of marks were assigned to these criteria. This inflated candidates' marks.

Some centres failed to show how marks were assigned to the criteria. While marks were assigned, it was unclear how the marks were awarded and almost always, candidates were awarded full marks. The team also noted that the criteria must be specific to the task at hand. In an attempt to use the same criteria for more than one exercise, some centres allowed the use of a common mark scheme. There were cases in which one mark scheme was constructed to 'fit' all exercises. This is not recommended.

CARIBBEAN EXAMINATIONS COUNCIL

**REPORT ON CANDIDATES' WORK IN THE
ADVANCED PROFICIENCY EXAMINATION**

MAY/JUNE 2011

PHYSICS

**Copyright© 2011 Caribbean Examinations Council
St Michael, Barbados
All rights reserved.**

GENERAL COMMENTS

There was an increase in the number of candidates writing the Unit 1 examination from 2,982 in 2010 to 3,208 in 2011. However, the number of Unit 2 candidates decreased from 2,143 in 2010 to 2,079 in 2011.

In both units, a major concern was the failure of candidates to pay attention to significant figures in spite of the warning of penalties stated at the front of the exam papers. There were cases where the question data was given with three significant figures but candidates gave answers with only one figure, for example, 0.01 mol instead of 0.0114 mol [Question 6, Unit 1], causing all subsequent calculations to be inaccurate. Additionally, in responses to the same question the examiners also saw pressures written as 21 382.82 Pa. It is important that teachers stress the use of significant figures rather than merely the simplistic instruction '*Answer to two decimal places*'.

Physical quantities usually consist of a number and a unit but candidates at both levels were frequently omitting the units in their responses. Some candidates added 90 J + 475 K to get 565 J [Question 6 Unit 1] or subtracted distance in cm from the count rate, for example, 427 counts per minute - 30 cm = 397 counts per minute [Question 3 Unit 2]. These errors were very common. Teachers need to be aware of this problem and, throughout the course, emphasize the requirement that all physical quantities have a magnitude and a unit and that all equations have consistent units in each term.

Using the gradient of a graph to get an accurate mean value of a quantity is standard practice in Physics; however, many candidates in both units lacked this skill. In many cases, they were content to take two values from the table and substitute in the given formula, defeating the object of plotting a graph. Better candidates used the equation to find the significance of the gradient and hence the value of the required quantity (for example, Question 2 Unit 1 where the gradient was $\frac{1}{2}\sqrt{(T/\mu)}$). However, many forfeited marks by using points from the table rather than a large triangle on the graph for the calculation of the gradient.

DETAILED COMMENTS

UNIT 1

Paper 02 – Structured and Free Response Questions

Question 1

A weakness in deriving equations for a given situation was evident in this item about falling under the influence of gravity with a non-zero drag force. Candidates were expected to use the free body diagram in (a) (i) as a starting point but many of them tried to work backwards from the final equation for the acceleration.

The graph plotting was not, in general, of a high standard: the scales chosen for the log graph sometimes made the positioning of points difficult and the weaker candidates were unable to cope with $\lg(g-a)$ having both positive and negative values.

Question 2

The phenomenon called ‘resonance’ was known by most candidates but the concept of a standing wave being produced in the air column above the water and producing a loud sound was not well explained.

The graph required in Part (b) was drawn accurately by the majority of candidates but many of them subsequently lost marks by not getting an accurate value for the gradient or by not using it to determine the mass per unit length of the wire.

Question 3

Writing the definition of specific latent heat of fusion was expected to give candidates an easy mark. However, several candidates lost marks as a result of omitting fundamental parts of the definition such as ‘per kilogram’ or ‘at constant temperature’.

The use of a large gradient triangle for the two gradients would have given candidates full marks but some of them used points too close together or even points which were not actually on the line. Linking the slower temperature rise per minute for the liquid to the specific heat capacity also proved to be challenging for many candidates.

The calculations based on the graph in Parts (iv) and (v) were not well done: the use of unconventional units like J per minute should not be beyond the ability of candidates at this level. Teachers might need to give their students more practice to develop problem-solving skills, rather than simple questions which just require equation substitution.

Question 4

There were many good responses to this question about conservation of mechanical energy and projectile motion. Marks were lost by those candidates who, without explanation, used equations of linear vertical motion to calculate a horizontal velocity instead of energy conservation, used the wrong height in the energy calculation (this was quite common) or failed to apply $s = U_v t + \frac{1}{2} a t^2$ correctly with $U_v = 0$ for the vertical component of the motion of the skier.

Question 5

Candidates did not perform satisfactorily on this question. The idea that refraction is a *bending* of light caused by transition into a different medium and diffraction is the *spreading* of light due to an obstacle or gap was poorly understood and the discussions of the action of a grating were consequently poor.

Part (b) was a standard diffraction grating calculation. Obviously, some candidates did not have adequate experience of this type of problem and found it very difficult.

Question 6

In general, candidates' responses in this thermodynamics question were very poor. The few marks gained were usually for the calculations in Part (a) and Part (c) involving the application of the gas laws.

There seemed to be great difficulty in using the kinetic theory of gases and also in grasping the meaning of the first law of thermodynamics. Many candidates confused the concepts of heat, temperature and internal energy and used them interchangeably. On several occasions, the examiners came across equations similar to

$$\Delta U = \Delta\theta + \Delta W$$

(either written explicitly or implied) and some candidates even wrote "Heat energy evolved from the work done on the gas is 790 K -315 K" and proceeded in Part (d) to add 90 J + 475 K to get an increase in internal energy of 565J.

Teachers need to be aware that they cannot assume that, having passed CSEC Physics, all of their students will have understood the difference between *heat* and *temperature*. Without this concept it is going to be very difficult to get across the idea that the internal energy (and temperature) of a substance can be raised when the substance has not been heated. It would also help if teachers used the form of thermodynamic law stated in the syllabus $\Delta U = Q + W$ (sic, with no extra deltas) which can be read as *the internal energy can be raised either by heating or by doing work on it*, thus emphasizing the fact that doing work can also raise the temperature.

UNIT 2**Paper 02 – Structured and Essay Questions**Question 1

Magnetic flux density is defined from the equation $F=BIL$ where B and I are at right angles. Many candidates lost marks by not paying attention to details in their definitions omitting *per unit current* or *per unit length*. Some defined the tesla or the weber instead.

The drawings of the 'catapult' field around the current-carrying wire in a uniform field were extremely poor: most candidates had little idea of how the fields interacted to give an upward force on the conductor.

More care should have been taken with the derivation of the relationship between the crossed fields when the beam of electrons was undeflected. Many candidates' working could not be followed because they used the same symbol F for both types of force. However, the subsequent calculations were usually done accurately.

Question 2

A number of candidates were either unable to attempt this question or were only able to score one mark. This may have occurred if Module 2 was the last module taught and

therefore teachers rushed through this portion of the syllabus. Based on the responses, what was evident was that candidates require more help understanding digital electronics. Teachers need to be aware that there is a problem and seek to remedy this.

An RS flip-flop has the strange property that for *the same input* there are two different complementary output states. Most candidates who attempted this question did not understand this and performed poorly on Part (a).

Candidates experienced difficulties in attempting to show the connection of NOR gates to form a bistable. Many of them tried to use all four NOR gates on the Quad-NOR chip even if their rough work showed the correct circuit. Schools must find ways of purchasing the equipment needed for this section of the syllabus, if their students are to gain a full understanding of these circuits.

Overall, candidates were able to score better on the other parts of the question and showed a good grasp of the use of timing diagrams.

Question 3

The majority of the marks were awarded for adding radiation labels to an ‘absorption’ diagram and plotting a straight line graph. Candidates scored well on these aspects. They lost marks, however, for not being able to find the corrected count rate from the given data, and not manipulating the information to come up with the correct equation for the linear graph.

Question 4

The formula for the capacitance of a combination of capacitors in series was well known though candidates’ ‘proofs’ were not well set out or had no diagram. Many candidates misread Part (a) and had three capacitors even though the instructions were in bold.

Candidates’ charge/discharge circuits often included irrelevant components (for example, ammeters) and many of the circuits shown would not have worked. More circuit work in the laboratory would probably improve candidates’ ability to ‘read’ diagrams and set up circuits correctly.

The analysis of the graphical data provided proved to be challenging for some candidates. Only the better candidates understood the concept of a time-constant in seconds and were able to interpret the gradient correctly to obtain the value of C for the combined capacitors.

Question 5

Like the corresponding question on Module 2, the performance of candidates was very poor. Few candidates understood the principle of the operational amp. comparator and so they were unable to recognize that saturation occurs when one input voltage exceeds the other by a few microvolts. The production of a square wave with a non-unity mark to space

ratio by changing the reference voltage was therefore beyond the experience of most candidates.

From the more well-prepared candidates there were some good diagrams of the non-inverting amplifier in Part (c) and most of these were able to make good attempts at solving the numerical problems.

Question 6

Teachers will need to pay more attention to the teaching of the physics of nuclear fission judging from the many poor attempts at the first part of this question.

The calculations based on the comparison of nuclear fuel with fossil fuel were performed successfully by many. Weaker candidates had difficulty with using powers of ten on their calculators and quite a few were confused by the 25 per cent efficiency and as a result had an energy output greater than the input.

Paper 032 – Alternative to School-Based Assessment (SBA)

UNIT 1

Only eight candidates wrote this paper. Overall their performance was rather weak. Question 1, which concerned the data collected from an experiment on the collision of two pendulums, was not well done because, it seemed, candidates could not handle the trigonometry required.

The collection of data for the path of light through a prism in Question 2 using pins was not done carefully enough for candidates to plot good graphs from their data and so the submitted values of the refractive index were quite inaccurate. Perhaps these candidates lacked experience in doing simple optical experiments.

Question 3 which focused on finding absolute zero using a gas thermometer also proved to be unfamiliar to most of the candidates and their efforts were not very convincing.

UNIT 2

Most CAPE candidates are able to do the internal assessment at school and this paper continues to attract a very small number of entrants (that is, six candidates). Like the Unit 1 paper, there was one actual experiment and two written structured questions on this paper.

Question 1 required clear descriptions of how an electrolysis experiment would be conducted but candidates' poor English let them down.

The experiment in Question 2 was performed fairly well though some candidates had to enlist the supervisor's help in connecting the potential divider to the diode.

Similarly, the descriptions of experiments to illustrate exponential decay in Question 3 were poorly written but candidates were able to recover to some extent by drawing good graphs in Part (b) and concluding that the experiment showed the random nature of radioactive decay.

Paper 031 – School-Based Assessment (SBA)

Across both Unit 1 and 2, performance on the SBA component of the examination was consistent with that of 2010. However, there is one particular area of concern that has been noticed and needs to be addressed. There are numerous cases where only two assessments are done for a particular skill. This is inadequate. This stems from a misinterpretation of the CXC CAPE syllabus, (page 67, specific guidelines for teachers #3), which reads *The marks recorded for each skill must be the average of at least two separate assessments*. As a result, some centres submitted two assessments in each skill.

In some cases, those exercises did not meet CAPE standards and therefore moderators were hard-pressed to find legitimate exercises to review.

There has also been a noticeable increase in the number of centres for which adverse comments had to be made. These comments were directed at concerns that were addressed over the years. There was a recurrence of some of these concerns. These include:

Planning and Design (P/D) exercises

- Many of the exercises chosen could be found in a textbook. These types of exercises cannot be done as P/D exercises without modification.
- There was an apparent lack of guidance from the teacher. Some procedures were totally far-fetched and well nigh impossible.
- Most P/D exercises involved and were limited to the theoretical testing of a hypothesis. The team noted that very few P/D exercises were executed.
- There was an absence of mathematical concepts in those exercises that were executed.
- There were some exercises that were trivial. Invariably, teachers awarded full marks for these exercises.

Analysis and Interpretation (A&I) exercises

- Some centres tried to apply the same mark scheme to all A/I exercises.
- Some Observation/Recording/Reporting (O/R/R) criteria were mistakenly used as A/I criteria. This occurred most frequently in the exercises that involved the plotting of graphs.
- There was a general lack of discussion of errors that were peculiar to certain exercises. The analysis aspect of the skill was therefore lost.
- Significant figures were incorrectly applied.
- Units were omitted where they were required and inserted where they were not required.

There were instances where there was no evidence that the other skills Manipulation/Measurement and Observation/Recording/Reporting were assessed. Yet still

candidates were awarded full marks by their teacher. This inflates the marks and distorts the entire picture.

It should be stated that there were some positive indicators that should be noted, namely:

- There was some improvement in the quality of mark schemes in some centres.
- There is some evidence of communication among teachers who participate in the CXC marking exercises. However, the message has not gone to those who do not participate.

CARIBBEAN EXAMINATIONS COUNCIL

**REPORT ON CANDIDATES' WORK IN THE
CARIBBEAN ADVANCED PROFICIENCY EXAMINATION®**

MAY/JUNE 2013

PHYSICS

GENERAL COMMENTS

In 2013, the number of candidates who wrote the Unit 1 examination increased to 3621 from 3141 in 2012; the number of candidates who sat the Unit 2 examination increased to 2659 candidates from 2278 in 2012.

Overall, candidate performance improved. However, the improved performance on Paper 01 was not commensurate with the performance on Paper 02. The following concerns were noted for Paper 02 in both units.

There were instances where candidates failed to pay attention to the number of significant figures when writing final answers to questions, although the penalty was stated at the front of the examination papers. It is important that teachers impress upon their students the importance of significant figures. It seems that candidates did not completely appreciate that an answer cannot be more accurate than the accuracy of the variables/data used in the calculation.

Too many candidates stated their answers as a number only, without including the relevant unit. Teachers should emphasize to their students that all physical quantities have a magnitude and a unit.

A large number of candidates seemed to find it difficult to compose an adequate response to questions which require extensive verbal discourse. Questions in which the action word is *explain*, *describe* or *discuss* often elicited very weak responses.

Teachers are encouraged to take note of these concerns and to devise corrective measures. Students should be provided with adequate opportunities to practise writing answers to this type of question with particular attention being given to a structured approach. Some teachers may even find it useful to provide exemplars with sequentially numbered points designed to reinforce the logic of an explanation or discussion.

UNIT 1

Paper 01 – Multiple Choice Questions

This paper comprised 45 questions with 15 questions based on each of the three Modules: Module 1 – Mechanics, Module 2 – Oscillation and Waves, and Module 3 – Thermal and Mechanical Properties of Matter.

The performance of candidates on this paper was good. The mean score was 73 per cent; the standard deviation was 9.89; and reliability was 0.93.

Candidates performed best on Module 2, then Module 1 followed by Module 3. In each case the mean performance on the Module was greater than 54 per cent.

DETAILED COMMENTS

Paper 02 – Structured and Free Response Questions

Question 1

Most candidates made a fair attempt at this question.

For Part (a) (i), many candidates encountered difficulties calculating the expected values for the table because they did not use the value of g provided in the table of constants at the front of the examination

paper opting instead to use a value of 10 m/s^2 , which for most purposes is acceptable at the CSEC level but not at the CAPE level. Teachers should encourage their students to use the relevant values provided in the table of constants for all calculations in the examination.

In Part (a) (ii), many candidates overlooked plotting the point (0,0) from the data provided in the table and 1:3 scales were used in many instances. Teachers should encourage their students to use all the data provided when making plots and selecting a suitable scale.

For Part (a) (iii), the majority of candidates calculated the gradient of the graph and assumed that it was the height from which the ball was dropped — seemingly not recognizing that the height from which the ball was dropped was the area under the velocity/time graph.

In Part (b) (i), too many candidates did not recognize that g ought to have been negative in both these questions.

For Part (b) (ii), some candidates seemed to have interpreted *show* to mean that a qualitative description was required and presented an explanation, and in some cases an accompanying diagram. Teachers need to be aware of this and indicate to their students that *show* can have both qualitative and quantitative interpretations.

Overall, candidates' scores on this question were satisfactory with about 40 per cent of candidates attaining scores greater than 6.

Question 2

This question was attempted by all candidates. The majority of candidates scored within the range 7–14 marks. The modal mark was 13.

In Part (a), many candidates were unable to state the explicit similarities and differences between transverse and longitudinal waves, and to cite appropriate examples of each. Consequently, candidates lost some or all of the marks in this question.

For Part (b), while many candidates knew the wave equation, a number of them did not accurately factor into their calculations the temperature dependence of the speed of sound. Most candidates scored either 1 or 2 marks in this section. Teachers should emphasize this relationship to their students.

Part (c) was generally well done by candidates. The biggest challenge was candidates' inability to choose an appropriate scale for the values to be plotted. However, most were able to use the graph plotted to determine the speed of sound. A few calculated the speed of sound by non-graphical methods. Teachers need to be aware of this and to urge their students that when instructed to *use the graph* that they should so do.

Overall, this question was fairly well done with approximately 70 per cent of the candidates scoring 7 marks or more.

Question 3

Performance on this question revealed that the mathematics skills of many candidates are weak. This weakness in mathematical skills contributed to the unsatisfactory performance. The modal mark for this question was 2.

Parts (a) – (b) require the use of a given formula to deduce the appropriate units. However, the formula given had a typographical error. The examining committee apologizes for the error and the inconvenience to the candidates.

In Part (c), many candidates attempted to do the ratio but they did not know how to introduce the constant of proportionality, k . Candidates who introduced the constant mistakenly thought that it was Boltzmann's constant, and used this in their calculations. Many candidates did not know how to do the manipulations to get the 1.07 asked for in the question. This led to strange mathematics, in which too many candidates presented anything they thought would get the desired answer.

Teachers should encourage students to practise the correct way of writing root-mean-square speed using symbols. The majority of candidates did not write this correctly, using many variations instead of the correct $\sqrt{\langle c^2 \rangle}$ or $\sqrt{c^2}$.

Teachers and students should also pay adequate attention to mathematical skills necessary for performing calculations in Physics. Too many candidates could not make a serious attempt at this question as they did not know the difference between a square and square-root.

Candidates performed best on Part (d). However, several candidates

- missed the concept that the volume remained constant through the process.
- did not use the correct symbols, using $pV = NRT$ or $pV = nrT$ instead of $pV = nRT$.
- had poor math skills which prevented them from transposing the formula to get the correct answer for the new value of n .
- used the general gas equation with some indicating that if V is constant then $p = nRT$.

Part (e) proved to be the most difficult part of the question for those who attempted it. While some candidates knew that the work done was the area under the graph, many of them did not calculate this correctly. They either did not calculate the whole area, or they did not use the scale on the graph correctly. Many also used the method of counting squares to find the area.

This method was not the most appropriate for the question, but it could be done. Some candidates read off the wrong values, and others found the gradients of the lines. Some candidates even used $W = p \Delta V$, disregarding the fact that the pressure was not constant for the process.

The majority of candidates who attempted Part (f) did fairly well, even if they could not do any other part of the question.

This question again was not a difficult one, however, it did indicate that the mathematics skills of many candidates were lacking and this contributed to poor performance on the question.

Question 4

Overall, this question was poorly done.

In Part (a), the definition was worth two marks and most candidates did not produce a response that was satisfactory enough to gain both marks.

While most candidates demonstrated a general understanding of the concept of *moments*, the ability to use this knowledge to answer the question was lacking. For example, the fulcrum (pivot) of a see-saw lies at its centre, but in the diagrams, most candidates illustrated the persons sitting at the 'ends' of the see-saw with the fulcrum 'shifted' close to the 100-kg person. More importantly, it was not made clear that the distance of the 50-kg person has to be *at least twice* that of the 100 kg person from the pivot to achieve balance and/or lift.

Again, in Part (b) (i) an accurate definition proved challenging. Candidates did not include the concept of 'a system of colliding objects' or 'with no external forces acting.'

In Part (b) (ii), several candidates did not properly identify the momentum equation which would have subsequently allowed them to accurately substitute the values of the velocities from the table to achieve the mass ratio. This led to them *incorrectly* equating for example, $m_1 u_1 + m_1 v_1 = m_2 u_2 + m_2 v_2$, where u represented velocity before collision and v represented velocity after collision.

Additionally, most of those who were able to accurately simplify the equation were unable to correctly obtain the ratio. Instead they derived its reciprocal.

For Part (b) (iii), most candidates were able to effectively state the general equation for the kinetic energy of the objects but did not calculate the total kinetic energy before collision. In their calculations, many candidates either omitted the ' $\frac{1}{2}$ ' or forgot to square the v . A few of them used the momentum equation.

In Part (c), most candidates who gained results from their calculations correctly inferred whether the collision was elastic or inelastic.

Question 5

In general, the responses to this question were fairly good. The majority of candidates earned between 3 and 11 marks, with a modal mark of 10 from a maximum of 15.

For Part (a), some candidates did not realize that the stationary wave consisted of two full wavelengths occupying the distance of 0.4 m. When the alternative formula of $f_n = nv/2L$ was used, many candidates used $n = 5$ nodes as opposed to 4 antinodes and so produced an incorrect answer. It was also expected that at this level, candidates ought to be using $v = f\lambda$ as opposed to using speed = distance /time to solve for wave parameters.

The responses for Part (b) were quite poor since a large number of candidates did not know the equation $v = \sqrt{T/\mu}$.

In Part (c), many candidates did not correctly interpret the word *determine* and simply defined the wave parameters required. It was also evident that many candidates could not correctly transpose a simple mathematical equation to solve for unknowns. Many candidates also appeared to be unable to recognize that the angles given in the equations supplied were expressed in degrees. Teachers are encouraged to ensure that all their students are familiar with and can manipulate problems expressed either in radians or degrees.

For Part (d), the majority of candidates did not pay attention to the frequency of the wave and attempted to describe applications that were not associated with waves with an ultrasonic frequency. Also, explanations given for the practical application were often quite unsatisfactory.

It is suggested that in order to prepare for questions of this nature, teachers should strive to provide students with opportunities via research projects, or presentations to appreciate the applications of Physics in daily life and (ii) to place more emphasis on the teaching of stationary waves and practice questions.

Question 6

Although, this question was attempted by most of the candidates, the majority did not perform well. The modal mark was 2.

In Part (a), the majority of candidates did not draw a 3D diagram. In a few cases where candidates drew a 3D diagram, they failed to label the area A properly. Some who drew and labeled the 3D diagram

properly were unable to prove the equation, hence earning the marks for the diagram but not for the proof.

For Part (b) (i), most candidates were able to apply the formula to calculate the pressure at a depth of 2.5 km. In this question, however, a number of candidates used ‘G’— the universal gravitational constant, instead of g — the acceleration of gravity, to perform the calculation. Teachers should make the distinction between both of these constants very clear to their students.

In Part (b) (ii), most candidates knew the formula for Young’s modulus (stress/strain). However, many of them were unable to move beyond the recall of this formula to calculate the decrease in length of one side of the cube.

For Part (c) (i), there is a clear distinction among proportional limit, elastic limit and yield point in terms of definition and position on the force/extension graph. Many candidates did not seem to know this distinction — indicating that x on the graph was the elastic limit when in fact it was the proportional limit. Teachers need to be aware of this and to point out the difference among these three terms to their students.

In Part (c) (ii), many candidates did not make the distinction between *strain* and *strain energy* and hence could not calculate strain energy using either area under that graph or the formula $\frac{1}{2}Fx$. As a result, many candidates got this question wrong.

Generally, this question was fairly well done by the candidates but converting from one prefix to another seemed to be challenging for many of them (gigapascals to pascals).

Paper 032 – Alternative to School-Based Assessment (SBA)

Question 1

For this experiment, candidates were required to list the apparatus required to determine Young’s modulus for a wire specimen. A diagram of the set-up was required as well as the procedure, manipulation of the results and the method for calculating the Young’s modulus of the wire.

A significant number of candidates could not list the apparatus required for this experiment. Candidates suggested that the vernier calipers should be used instead of a vernier scale. Few candidates could produce the correct diagram for the experiment. While most candidates could state the procedure used to execute the experiment, few could present it in the correct order.

Candidates seemed unsure of what was required when asked to manipulate the results. Most of them could recall the equation for Young’s modulus, $E = \text{Stress} \div \text{Strain}$, but failed to state that the quantity could be obtained if a graph was plotted and the gradient was determined. Candidates did not link the gradient of the stress/strain graph and the Young’s modulus of the wire.

Question 2

Candidates were required to conduct an experiment to investigate the refraction of light at an air/perspex boundary using a light source and a number of pins.

There was no clear indication that some candidates could actually set up the apparatus. There was some evidence that suggested that a rectangular block had been used by some candidates. Many candidates

measured the angle between the straight side of the glass block and the ray rather than the angle between the ray and the normal.

Those candidates who correctly measured the angles α and β were able to complete the table showing these angles and the values for $\sin \alpha$ and $\sin \beta$.

Few candidates could produce graphs with the appropriate scale. Some candidates plotted graphs of $\sin \beta$ versus $\sin \alpha$.

Extrapolation of the line proved difficult for most candidates. Some candidates tried to calculate the critical angle rather than using the graph to find the value.

Question 3

Candidates were required to find the specific heat capacity of an unknown liquid by manipulating the data provided, plotting a graph and finding the gradient of the graph.

There was very little difficulty in completing the table and plotting the graph. Most candidates were able to determine the gradient; however, there was some difficulty in calculating the value of the specific heat capacity.

Candidates were challenged in transposing the equation, $V I T = m c \Delta T$, to find the value for c , the specific heat capacity, given that the gradient of the graph would yield $\Delta T/t$ and the transposed equation would yield $t/\Delta T$. Very few candidates recognized that the gradient had to be inverted in order to find the value for the specific heat capacity, c .

There was enough evidence to indicate that candidates understood the precautions that were necessary for the execution of the experiment.

UNIT 2

Paper 01 – Multiple Choice Questions

This paper comprised 45 questions with 15 questions based on each of the three Modules: Module 1 – Electricity and Magnetism, Module 2 – AC Theory and Electronics, and Module 3 – Atom and Nuclear Physics.

The performance of candidates on this paper was quite good. The mean score was 74 per cent; the standard deviation was 10.03; and reliability was 0.94.

Candidates performed best on Module 1, then Module 3 followed by Module 2. In each Module, the mean performance on the Module was greater than 59 per cent.

UNIT 2

Paper 02 – Structured and Free Response Questions

Question 1

Most candidates scored very high marks on this question — approximately 65 per cent of the candidates scored more than eight marks of the fifteen.

In Part (a), the majority of candidates were able to draw the required circuits and to derive the expected expression for resistors in parallel.

Part (b) (i), was well done by most candidates. Weaker candidates were unable to score the marks here because of poor mathematical skills.

Part (b) (ii) was perhaps the most challenging for the candidates. About 50 per cent of them were able to earn the marks while some of the remaining candidates had difficulty determining the total current I_T and those who did calculate I_T , were unable to follow through to calculate V_2 because they did not realize that they had to use $V = IR_{eq}$.

Part (c) (i) was generally well done by candidates. The only observed challenge that candidates seemed to have had in this question was selecting an appropriate scale for the graph of I vs V_T . A few candidates interchanged the axes and plotted V_T vs I instead.

For (c) (ii), most candidates were able to read off points to calculate the gradient but the problem in many cases was the selection of the points. Many of them did not select a large triangle. Teachers need to be aware of this and to impress upon their students the importance of selecting points that create a triangle of adequate size.

Question 2

This question was not very well done with just about 40 per cent of the candidates scoring at least seven marks. Most candidates who attempted this question earned the 2 marks allocated to Parts (a) (i) and (iii), but many did not get the one mark allocated to Part (a) (ii), which required them to read off the value from the graph. Candidates did not seem to recognize that *unity gain bandwidth* was equivalent in meaning to the bandwidth for a gain of unity.

For Part (b) (i), majority of the candidates failed to recall that both inverting and non-inverting amplifiers utilize negative feedback so that many of the circuit diagrams were drawn inaccurately.

In Part (b) (ii), some candidates seemed not to have realized that they were required to use the resistor values supplied earlier in the question to calculate the gain of the amplifier so a number of them lost the calculation mark. A significant number of candidates misread 330 K Ω for 300 Ω and so arrived at an incorrect value for the gain.

In Part (b) (iii), the instruction *use the open loop gain-frequency curve* seemed to have been ambiguous to some candidates as many of them did not indicate the required value on the graph.

For Part (b) (iv), many candidates did not get the answer required. Although they knew the correct formula, they were unable to manipulate it appropriately.

There seemed to have been some ambiguity in candidates' interpretation of what the questions in Part (b) were asking. In Part (b) (v), candidates seemed to have believed that the op amp was removed from the circuit (based on the wording of Part (b) (iv) before) and in Part (b) (vi), candidates did not recognize that the circuit being referred to was the one in Part (b) (v).

Overall, candidates performed unsatisfactorily on this question.

Question 3

Performance on this question was fair.

Part (a) of the question was the most widely known and contributed significantly to the marks gained by candidates.

In Part (b), a considerable number of candidates did not seem able to convert energy from Joules to eV and vice versa. Although the more well-known derived units can be used wherever applicable, candidates need to realize that many of the more specialized areas of Physics (and indeed of other sciences which use physical units) use their own set of units and it is important that they are able to convert from one set of units to another.

For Part (c), candidates were required to plot a graph of *Stopping Potential vs Wavelength*. Perhaps the fact that most physics experiments require the plotting of a straight line, many candidates used the points provided to plot a straight line when the relationship between these two variables would yield a curve. The situation was further confused by the fact that the last section of the question required candidates to use their graph to obtain a value for the cut-off wavelength, a result construed to have been more easily obtained from the intercept of a straight-line graph.

Question 4

In Part (a) (i), the proof was generally well done.

For Part (a) (ii), the calculation of V using the given expression elicited some strange responses because many candidates substituted the values of the variables correctly but managed to get the wrong answer. Others substituted the wrong values for the variables although several of these were given in the answer booklet. A fairly significant number of candidates appeared to be unfamiliar with the meaning of the prefix *kilo*.

The indications are that many candidates need to be guided on the proper use of calculators. Students who complete the CAPE Physics programme should have an ingrained knowledge of the more common quantitative prefixes. Such prefixes on a prominently displayed poster in the Physics laboratory could be of some help in achieving this objective.

In Part (b) (i), the calculation was well done for the most part but many candidates did not recognize that they needed to use the right hand grip rule to get the direction of the magnetic field. Teachers should place a bit more emphasis on the application of this rule by assigning and correcting practice problems which require its use.

Part (b) (ii) a) was poorly done. The majority of candidates did not recognize that the horizontal component of the electrons' velocity would be parallel to the magnetic field and hence would be unaffected by it.

In Part (b) (ii) b), very few candidates recognized that the vertical component being perpendicular to the field will experience a constant force perpendicular to the direction of motion, that is, a centripetal force which will cause the electrons to move in a circle.

For Part (b) (ii) c), the majority of candidates did not seem to understand what was required. In fact, this part of the question discriminated between the very good candidate and the average one. The good candidates were able to come up with partial answers and a few well prepared ones were able to

produce completely correct answers. Teachers are encouraged to explain, probably with the aid of models, what happens to a charged particle moving in a magnetic field.

Question 5

In Part (a), nearly half of the candidates failed to realize that with three inputs there would be eight possible unique combinations of ones and zeros.

Students must be able to count in binary and realize that N binary digits can be used to represent 2^N different numbers (or combinations of ones and zeros).

For Part (b) (i), the majority of candidates did not seem to understand that what was required here was an explanation of how the operational amplifier was used as a comparator in the given circuit. Too many of them tried to explain how the entire circuit functioned. Teachers should provide their students with some experience in qualitative circuit analysis. One of the skills that should be derived from the study of electronics at this level is the ability to analyse simple circuits. Candidates should be able to explain the function of each component and subsystem of simple circuits.

Because of candidates' inability to analyse circuits component by component or subsystem by subsystem, many of them provided the answer to Part (b) (ii) in their response to Part (b) (i). There was no penalty for this. Nonetheless, teachers should emphasize the basics of writing examination answers and encourage students to answer questions in the contexts in which they are asked.

For Part (b) (iii), while a considerable number of candidates were able to describe the operation of a relay in detail, they could not give the reason why it was necessary in this particular circuit.

Part (c) required the use of equations which were not explicitly stated in the syllabus. Candidates were not penalized.

Question 6

Performance on this question was unsatisfactory. Several candidates were unable to earn at least one of the 15 marks allocated. This was particularly evident in Part (c).

Part (a) focused on the decay of a radioactive particle and was generally well known by prepared candidates. However, too many candidates were unable to earn the mark allocated to this part.

For Part (b), candidates were required to manipulate an equation that models radioactive decay. It was evident that for the majority, the necessary mathematical skills were lacking.

Part (c), required candidates to calculate the activity of radioactive nuclei and this presented difficulty for most candidates. Again, it was evident that the necessary mathematical skills were lacking.

In Part (d), candidates were presented with a circuit to model the decay of a radioactive isotope.

Again, the performance on Part (d) was similar to that of Part (c) revealing a lack of necessary mathematical skills.

Paper 032 – Alternative to School-Based Assessment (SBA)

Question 1

Candidates were required to heat a sample of water to 100 °C, measure the resistance of a thermistor and record the resistance from a digital multimeter. The data was used to complete a table of temperature in °C, resistance in temperature in kelvin. Further, the natural logarithm of the resistance and the reciprocal of the kelvin temperature were also required.

A graph of $\ln R$ versus $1/T$ was required from which the thermal exponent of the thermistor was determined.

The resistance of the thermistor at a temperature of 71°C was to be extracted from the graph.

Candidates had little difficulty completing the table. There were a few instances where temperature was not given in kelvin.

Most candidates were able to compute the natural logarithm of the resistance and the reciprocal of the kelvin temperature.

Many candidates did not draw graphs with the appropriate scale. Those who produced graphs of appropriate scale were able to draw the line of best fit.

Candidates were required to determine, from the graph, the resistance of the thermistor when the temperature was 71°C. Those candidates who were able to successfully plot the graph were able to extract this information from the graph.

Question 2

Candidates were required to complete a table using an equation that was provided.

Many candidates did not realize that the quantity a , in the equation, had units $\text{m} \times 10^{-6}$, and this was not considered when finding the value of a^3 . As a result, their values for q were incorrect. Those who recognized this fact were able to successfully complete the table. Very few candidates could explain why droplets moved in different directions, or why the chamber had to be irradiated with x-rays. In addition, very few responses explained why the experiment would only work for a limited range of voltages.

Too many candidates were not able to use the graph of terminal velocity versus time to determine the separation of the plates. Those candidates who successfully determined the separation of the plates were also successful in finding the terminal velocity of the oil drop.

Question 3

Candidates were required to design an experiment for collecting data to plot the gain – frequency curve of an inverting amplifier.

The majority of candidates could not correctly list the apparatus that was required or draw the circular circuit. In many cases, candidates merely drew the circuit for an inverting amplifier without including the input signal or the means of measuring either the input or output.

Few candidates could outline the procedure for conducting the experiment, tabulate the results or describe the treatment of the results. Few candidates realized that the *log-frequency* graph had to be plotted.

Paper 031—Report on School Based Assessment (SBA)

The following issues arose out of the moderation exercise for both Units 1 and 2.

Number of Assessments

At several centres only two assessments were done for each skill. Some teachers continue to misinterpret a clause in the CAPE Physics Syllabus (p. 67), Specific Guidelines for Teachers #5, which states:

The mark recorded for each skill assessed by practical exercises should be average of *at least two* separate assessments.

As a result, many centres submitted two assessments only for each skill. In some of these situations, the two exercises did not satisfy the basic CAPE standards and therefore moderators were hard pressed to fine legitimate exercises to moderate.

Assessment of Manipulation and Measurement

In some cases, there was no way of verifying how the manipulation and measurement scores were determined. There was no record of the marks in students' books.

Mark Scheme

- The number of centres for which mark schemes were not submitted remains a cause for concern and *may lead to delayed results for such centres.*
- There were several cases where mark schemes were inadequate for some skills. Some centres continue to assess exercises using criteria that do not match the skill, for example, many centres include plotting points as Analysis/Interpretation criteria when it is an Observation/Recording/Reporting skill. Invariably, too many marks were assigned to these criteria. This practice inflated students' marks.
- Some centres failed to show how marks were assigned to the criteria. While the marks were assigned, it was unclear how the marks were awarded and almost always, candidates were awarded full marks. The team also noted that the criteria must be specific to the task at hand. In an attempt to use the same criteria for more than one exercise, some centres allowed the use of a common mark scheme. There were cases in which one mark scheme was constructed to 'fit' all exercises. This is not recommended. *Centres are urged to comply with the CXC SBA guidelines.*

CARIBBEAN EXAMINATIONS COUNCIL

**REPORT ON CANDIDATES' WORK IN THE
CARIBBEAN ADVANCED PROFICIENCY EXAMINATION®**

MAY/JUNE 2014

PHYSICS

**Copyright© 2014 Caribbean Examinations Council
St Michael, Barbados
All rights reserved.**

GENERAL COMMENTS

In 2014, the number of candidates writing the CAPE Physics examinations was as follows:

Unit 1: 3372 candidates

Unit 2: 2637 candidates

This reflected a decrease in the numbers writing the CAPE Physics 2013 examinations in which case the numbers were 3621 (Unit 1) and 2659 (Unit).

A recurring problem in both units is the large number of candidates who have not mastered fundamentals such as:

- *Unit conversion* — this occurs in every area of physics, even in linear units where converting between different divisions of a meter millimeter – meter, nanometers – micrometers - centimeters defeats candidates
- *Transposing of algebraic expressions* : especially where other operations such as square roots are involved, for example: to make T the subject of the formula $\frac{\lambda}{T} = \sqrt{\frac{g\lambda}{2\pi}}$ expressing derived units in terms of fundamental units (for example: capacitance in terms of fundamental SI units)

Teachers should place emphasis on completely eliminating these weaknesses.

The number of null responses in the Atomic and Nuclear Physics Module (Unit 2, Module 3) continues to be alarming. Some attention could be given to teaching these topics earlier in the year.

DETAILED COMMENTS

UNIT 1

Paper 02 – Structured and Free Response Questions

Question 1

This question was fairly well done. The topic appeared to be well known and the only section which presented major difficulty was the one which required candidates to find the horizontal range of a projectile. The most common error was where candidates used the velocity of projection multiplied by the time of flight to find the horizontal range.

Teachers are encouraged to remind their students that most projectile calculations require the horizontal and vertical components of the motion to be treated separately and independently.

Question 2

There was generally weak performance on this question. One area of weakness was algebra. Given two algebraic equations, one of which included a square root, and asked to combine them and manipulate into a given form, the majority of candidates got lost in the algebra and could not obtain the result.

Teachers should assign a significant number of problems involving algebraic manipulation so that their students get the required practice. They should also encourage students to practise on their own as facility with algebraic manipulation comes with practice.

A majority of candidates did not know the components of the e/m spectrum nor the wavelength boundaries of the different components. This is important general knowledge and teachers should devise creative methods of ensuring that this is studied and learned. The mnemonic used to memorize the colours of the visible spectrum has been outstandingly successful. Perhaps a similar mnemonic could be developed for the entire e/m spectrum.

Most candidates knew how substitute in the given equation and use their calculators to find the result.

Question 3

For Part (a), a majority of students were able to calculate the volume inside a cylindrical glass tube given appropriate data about the geometry of the tube. In Part (b), candidates were given graphical data and were required to decide which variable should be assigned to the x-axis and which to the y-axis. A large number of candidates made the assignment incorrectly.

Teachers are encouraged to make sure that their students first of all, know how to distinguish between the independent variable and the dependent variable. It should then be stressed that the independent variable is the one which is assigned to the x-axis (abscissa) and the dependent variable to the y-axis (ordinate).

A majority of candidates did not elaborate on the answer when asked what happened to the volume of a real gas as its temperature was decreased towards absolute zero. It appears that students are not being taught to visualize the conditions inside a gas in accordance with kinetic theory. Kinetic theory lends itself to visualization. It is very important when teaching the gas laws and kinetic theory, that teachers help their students create a visual picture of what is happening inside a gas, that is, the microscopic view. There are many applets online which can help with this.

Question 4

This question was poorly done despite its focus on fundamental thinking skills. A large number of candidates could not explain why an object would be accelerating while going around a circle at constant speed, suggesting that their concept of acceleration was not fully established. It is expected that teachers make every effort to ensure that concepts such as these are internalized at the CSEC level.

The dimensional analysis using base units was also poorly done. Many candidates were unable to use the equations of kinematics to find the velocity of a car with a given initial velocity and constant

acceleration over a specified distance. Here again, fundamental concepts which should have been established at a lower level are missing. Perhaps some coordination between CAPE and CSEC teachers would assist in ensuring that these lacunae in basic understanding are not propagated.

In the section requiring candidates to indicate the forces acting on an object undergoing circular motion in a vertical circle, candidates' drawings indicated that they thought of the centripetal force as one of the active forces and not as a requirement for circular motion.

Responses to this question suggest that circular motion is not a clearly understood concept and that teachers should devote special effort towards ensuring that more of their students develop a thorough understanding of the topic.

Question 5

This question was very poorly done. Most of the formulae relevant to this question were recalled accurately by the majority of candidates. In one special case where a formula was to be derived from a diagram, there was the peculiar situation of candidates being able to recall the derivation but unable to recall the diagram on which it was based.

Unit conversion continues to present a problem and it was particularly apparent in this question. Conversions between mm and metres were most often incorrectly done and so was the conversion between metres and nanometers. This difficulty would be considerably diminished if teachers habitually use scientific notation and encourage/require the use of such notation by their students. Along with this, there should be a thorough (recitative) grounding in the meaning and expression of the scientific prefixes: micro- milli- centi- kilo- mega- etc.

Particularly evident in the responses to this question was the perennial problem of transposing of variables in a given equation, that is, changing the subject variable. This problem is eminently soluble and whichever technique is used, the brute force solution of drills will definitely work. Every physics teacher should commit to ensuring that no student leaves class without mastering this basic algebraic skill.

Question 6

Students demonstrated fundamental knowledge of the heat transfer processes and of the greenhouse effect. A vast majority of candidates were unable to make the link between the processes and their application to the design of solar water heaters. Many candidates, although knowing the formula for thermal conduction through a regular solid, were unable to apply it to the practical situation presented in this problem. It appears that although candidates can quote the formula quite accurately, there is a gap in their understanding of the meaning of each term. Teachers should be aware of this gap and endeavor to close it. One possible way of accomplishing this is by identifying, correctly, the troublesome variables in a wide variety of situations. The internet and the problems at the end of chapter in any of the well-known Physics texts can be of great assistance. Remember, the student does not necessarily have to solve the problem. The purpose of the exercise would be to correctly identify which item of given data corresponds to which variable in the formula being studied.

UNIT 2**Paper 02 – Structured and Free Response Questions**Question 1

This question was well done indicating that the topic was properly taught and well understood. A number of candidates experienced difficulty in finding the time constant of the given exponential decay curve. Some were not able to draw a proper tangent and even among those who drew the tangent competently, many did not realize that it could be read off directly from the time axis. Those who attempted to calculate it directly did not do so well either.

Drawing a tangent to a curve, that is, variable slope, is a skill which all students should acquire. Teachers should drive home the main features of this exercise by reducing it to a set of sequential steps and having their students master each step.

There were still a number of candidates who appeared to have difficulty drawing a proper graph and ended up with inappropriate scales making the extraction of data from the graph exceedingly difficult.

Although overall performance on this question was good, there were a fair number of candidates who did not know the SI unit for capacitance.

Question 2

This question had the best performance on the entire paper. The data for the graph was calculated and recorded accurately and for the most part the graphs were properly drawn and well presented. There were still a number of candidates who had difficulty choosing proper scales for their graph.

Question 3

This question had one of the worst performances on the entire paper. The majority of candidates could not derive the nuclear absorption equation given the initial isotope, the bombarding particles and the final product. There is very little intrinsic difficulty in this exercise and so the remaining conclusion must be that some candidates were not properly prepared or not prepared at all for this topic. The examining committee encourages all teachers of CAPE Physics to plan and execute their teaching schedule effectively so that all topics are covered.

Similarly, the vast majority of candidates could not describe a laboratory experiment to measure the half-life of a given radionuclide. Many candidates were able to give examples of the properties of a radioisotope which were employed in radiotherapy but there was an overwhelming bias toward diagnostic radiotherapy applications. Teachers should make sure that their students are exposed to the requirements of curative or corrective radiotherapies.

Question 4

This was the worst performing question on this paper. Approximately 29 per cent of candidates scored zero. Most candidates could calculate the electric field between parallel plates. The parallels between the motion of charged particles in a uniform electric field and that of a mass in a uniform gravitational field appear to be unfamiliar to a large number of students. This parallel is expressly stated in the Unit 2 syllabus. In cases where Unit 2 is taught before Unit 1 or where candidates are doing Unit 2 alone, teachers have the responsibility to teach parabolic motion in Unit 2.

Question 5

This was the second best performing question on the paper. The modal score of 15 out of 15 suggests that there are many candidates for whom this topic is well taught and well understood. Among the more poorly performing candidates, there were many who could recognize or draw the basic logic gates and who could derive a truth table from a given logic circuit. Some candidates submitted responses with 3 and 4-input logic gates. Teachers should frequently refer their students to the syllabus which is available online. In this case, the CAPE syllabus states that all logic circuits examined at CAPE will be restricted to two inputs.

Question 6

Performance on this question was generally poor with approximately 25 per cent of candidates earning the modal score of zero and nearly 20 per cent not attempting the question at all.

Experience continues to show that the topics at the back of the syllabus are most likely to produce these poor responses. A likely reason for this is that many teachers arrange the syllabus material in chronological order and topics at the back of the syllabus, thus assigned to the end of the teaching period, are sometimes omitted. We recommend that teachers bear this in mind when planning their teaching schedule for the term.

Conversion from joules to eV and vice versa: these conversion problems can be easily solved by giving students a sufficient number of practice examples for the process to be imprinted on their subconscious.

Paper 032 – Alternative to School-Based Assessment (SBA)

A catalog of the problems encountered in SBA assessment is presented below. Teachers are asked to note them carefully and to take appropriate remedial action where necessary.

Standard of the Labs

- Too many standard experiments used for Planning and Design
- Poor hypotheses accepted for Planning and Design
- Planning and Design experiments should be written up in two parts:
 - Part A in which the exercise is planned in its entirety
 - Part B in which the execution of the experiment is recorded
- Too few basic Analysis and Interpretation exercises

Mark Schemes and Marking

- Not enough breakdown for each criterion
- Teachers not following their own mark schemes
- Mark schemes with more than 24 points used and submitted
- Mismatched criteria – Analysis and Interpretation actually belonged to Observation Recording and Reporting.
- Wrong mark schemes submitted – mark schemes received did not correspond to the labs that were in the candidates' books.
- Inconsistent marking – some candidates were awarded a mark for satisfying a particular assessment criterion while other candidates did not receive the mark for similar or almost identical work.
- Little or no feedback comments in lab books.

Disorganized Presentation

- No dates on lab reports
- Lab reports not indexed
- Pages not numbered
- Reports presented in random order in each lab book

Improvements

It is pleasing to note that:

- Some schools are reading the subject report and are making improvements to their SBA performance.
- Some very original, non-standard Planning and Design experiments are being done.
- More schools are sending in acceptable mark schemes.

CARIBBEAN EXAMINATIONS COUNCIL

**REPORT ON CANDIDATES' WORK IN THE
CARIBBEAN ADVANCED PROFICIENCY EXAMINATION®**

MAY/JUNE 2015

PHYSICS

**Copyright© 2015 Caribbean Examinations Council
St Michael, Barbados
All rights reserved.**

GENERAL COMMENTS

In 2015, 3674 candidates wrote the Unit 1 examination while 2494 wrote Unit 2. This represented a nine per cent increase in Unit 1 and a five per cent decrease in Unit 2, compared with 2014. Overall, there was a 2.6 per cent increase in the number of candidates writing the examination. The number of candidates writing the CAPE® Physics 2015 examinations was as follows:

General performance was not markedly different from that of previous years.

A recurring problem mentioned in several prior school reports, and which is very much in evidence again this year, is the significant number of candidates in both units who have not mastered fundamentals such as the following:

Unit conversion — this occurs in every area of physics yet candidates continue to find it difficult. This is evident even in linear units where converting different divisions of a meter is required – millimeter, nanometers – micrometers - centimeters defeats candidates. Simple conversion such as Celsius to Kelvin and vice versa are also problematic for a large number of candidates.

Transposing of algebraic expressions for example:

$$\text{to make } e \text{ the subject of the formula } E = \frac{fL}{eA}$$

Expressing derived units in terms of fundamental units

capacitance in terms of fundamental SI units

These weaknesses can be eliminated almost completely by sustained practice. We encourage teachers to ensure that students work enough practice problems.

At both levels (Units 1 and 2) there were several instances where candidates stated their answers as a number alone, without including the respective unit. Teachers should emphasize to students; throughout the course; the requirement that all physical quantities have a magnitude and a unit.

DETAILED COMMENTS

UNIT 1

Paper 02 – Structured and Free Response Questions

Question 1

Most candidates did Part 1 (a) correctly. The most common errors were candidates stating inversely proportional to distance and inversely proportional to the radius squared. Candidates should be encouraged to quote r as the distance separating the two bodies.

Many candidates got Part (b) (i) correct either by finding g first and then using $W = mg$ or using $F = Gm_1m_2/r^2$. Too many candidates forgot to divide by two to find the radius or to square the radius in calculation. A significant number of candidates did not realize that F was in fact W and calculated F and used it as g in $W = mg$. Emphasis that W is the force due to gravity and distinguishing between F and g is needed here.

This section proved difficult for candidates. For Part (b) (ii), many candidates had the formula $E_p = mgh$ but could not apply it in this situation. Some did not realise that the radius was the height in this case. Many candidates substituted g as 9.81 ms^{-2} even though they were told it was the planet Mars.

For Part (c) (i), **the scale mark was checked for.** Too many candidates did not pay attention to guidelines for drawing a line of best fit and just drew a line passing through the first and last points.

A large number of candidates got the gradient wrong in Part (c) (ii) because they did not process the powers associated with each axis. Many candidates did not seem to have a concept of straight line analysis. This was evident by the number of candidates who got 4 out of 4 in drawing the graph but left out this. Straight line analysis is a vital concept in physics and should be practiced in both theory and labwork.

Question 2

The drawing of the graph was done by most candidates, this showed that they have acquired the basic skills needed to do such. The other sections were not well done.

Teachers need to spend a bit more time on this topic simple harmonic motion. Teachers should ensure that students at least know the basic theory and equations associated with the topic, which only comes from having the candidates practise more questions

Question 3

The section of this question which was widely known was Part (d), with most candidates getting three to five marks. Candidates had knowledge of types of thermometers and calibration of fixed points. It is believed though that candidates may not have read the question thoroughly and failed to give the appropriate thermometric property and the linearity expression to allow for unknown temperature to be obtained.

The sections which presented the most difficulty to candidates were Parts (b) (i) and b (ii).

Part (e) (i) was well known to in terms of substitution of temperatures, but candidates had difficulty writing a final expression in terms of R_0 . Most candidates did not attempt Part (e) (ii). If they had knowledge of the linearity expression of resistance, they certainly could not substitute and simplify the expression to yield a final answer.

Candidates did not understand the expression *what is meant by the term* and gave mainly the response of 0 Kelvin in Part (b) (i) and had poor responses for Part (b) (ii) regarding the comparison of the absolute thermodynamic scale of temperature o other temperature scales.

In Part (c), most candidates did not know the conversion factor of adding 273.15 to the centigrade value to obtain the temperature in kelvin.

Recommendations

More emphasis needs to be placed on the teaching of thermometers and temperature scales. Practical or even simulated activities involving calibration and the comparison of thermometers and their use in determining unknown temperatures must be incorporated. Manipulation of mathematical expressions needs to be encouraged.

Question 4

Part (a) was most widely known.

It proved difficult for candidates to get all four marks in Part (d). The component method and the calculation method was often made errors and most who got through this did not consider to find the direction.

Recommendations

Too many candidates did not know how to sketch a proper vector diagram in order to obtain a resultant. Candidates require more practice in this area.

Candidates should also practise the resolution of forces with given angles, with respect to the horizontal or to the vertical.

More work needs to be done in handling indices correctly

Question 5

The sections of this question which were most widely known and most frequently attempted were Parts (a) and Part (c) (i).

Part (b) presented difficulty to candidates.

Recommendations

Teachers should help students to arrive at a foolproof method of distinguishing between concave and convex whether by practice or by following a rule.

Teachers should also ensure that their students can produce correct ray diagrams and produce images for the more well-known scenarios (for example, magnifying glass, reading glasses etc.).

It appears that teachers also need to explain to students that an image will be virtual if the calculated image distance has a negative value.

Question 6

In Part (a), a formula for Young's modulus and manipulation of the formula to solve for an unknown did not present challenges. For Part (b), candidates were aware that in elastic deformation the body returned to its original length and shape, and linked that to the body obeying Hooke's law.

Most candidates could not describe the energy changes associated with elastic or inelastic deformation of a body.

Many candidates could not interpret the given data in order to make a correct substitution into a formula in Part (d) (ii) where the force being used ought to have to been (8000 x 9.81).

Recommendations

Performance on this question suggests that candidates need to be exposed to

- practical activities associated with bodies undergoing elastic and inelastic deformation.
- the relevance of lessons to real life
- a greater number of practice questions using the formula and manipulation of said formula to solve for unknowns
- simple engineering projects utilizing the principles of Hooke's law, Deformation and Young's modulus.

UNIT 2

Paper 02 – Structured and Free Response Questions

Question 1

Part (a) was not well done as many candidates were unfamiliar with resistivity. Part (b) was well known and attempted by almost all candidates.

Plotting of the graph in Part (d) (i) although a time consuming activity however the marks did not prevent candidates from scoring well on this section.

Although the plots were for the most part, well done, many candidates used inappropriate scales.

Recommendations

Teachers should reinforce definitions such as resistance and resistivity.

Candidates should receive enough practice in graph plotting to enable them to choose proper scales for a variety of scenarios. They should also be reminded that while it is desirable to fill as much of the graph paper as possible, that consideration should take second place to choosing scales which preferably are based on multiples of 2, 5 and sometimes 4, never 3.

Question 2

In Part (a) (i), drawing the inverting op-amp and stating the properties of the op-amp should have been the easy for candidates but they had problems drawing a simple inverting op-amp with feedback and labeling it correctly. Only a small percentage of candidates got this completely correct.

For Part (a) (ii) Many candidates were unable to distinguish between the properties of an ideal op-amp and the properties of a real op-amp.

A large number of candidates drew a non-inverting op-amp and even comparators, showing that they were not sure of the differences.

In Part (b) (ii), most candidates knew that the gain was the gradient of the straight line portion or V_{out}/V_{in} . The graph in this question was fairly well done. For Part (b) (iii), most candidates were able to interpret the shape of the graph and deduce correctly that the amplifier went into saturation.

In Part (b) (iii), few candidates were able to describe the shape of the graph and relate it to the working of the inverting op-amp.

Recommendations

From the responses submitted it appears that this section of the syllabus is not very familiar to the majority of candidates. Teachers should ensure that students spend time practicing questions on the basic op-amp and on the different operational amplifier circuits.

Question 3

In Part (b) (i) was generally well done, however some candidates were inconsistent with the order of accuracy in the table, while others were guilty of inaccurate rounding off to the correct decimal place. There were a few candidates who were unable to perform the appropriate calculations to complete the table.

For Part (b) (ii) most candidates were able to successfully scale and plot the values from their tables. In Part (b) (iii), most candidates were able to correctly evaluate the slope of the graph they plotted however, they neglected to put in the units. In many cases, candidates just assumed that the unit was in seconds. It should be stressed that the gradient unit may be found from the axes of the graph. A few candidates failed to make the link between the gradient of the graph and the decay constant.

Most candidates could not reconcile the concept of a property for Part (a) and could not match the property with an appropriate reason for usage. Many candidates confused the concept of ionizing ability with radiation energy level. Most just indiscriminately filled the boxes with their knowledge.

Most candidates were aware of the half-life equation, required in Part (b) (iv). Far too many candidates did not supply units with their answers, and as such were penalized.

There were candidates who were unaware of how to set up and numerate axes for negative values for Part b (ii). As a consequence, the $\ln(A/A_0)$ was set up as though positive values were being used and the values placed (0, -1, -2) ascending the axis.

Recommendations

Where possible, teachers should make use of multimedia. Videos of ionization radiation in a cloud chamber or the use of radioactive isotopes in medicine for diagnosis and treatment of cancer and other diseases etc. leave a longer lasting impression and cements understanding.

A review of fundamental concepts in the CSEC syllabus can help to create the fram of mind for students to focus on the topic at hand (work it into the set induction, for example). Although syllabus completion imposes some time constraints, the basics (units, appropriate significant figures, graphing, to name a few) should not be neglected.

Question 4

Part (b) (i) was well known and attempted by almost every candidate.

For Part b (ii), most candidates were able to recall correctly the equation relating power, input voltage and current and to make appropriate substitution into it.

In Part (d), candidates were not familiar with the concept of permittivity even though they were familiar with the equation.

Recommendations

Reinforce the learning and understanding of definitions...students seemed to be familiar with the different elements involved in this question but could not state them properly especially with regards to the conductor, force and field being mutually perpendicular to each other. The use of correct number of significant figures and units should also be reinforced.

It appears that students need to be taught how to interpret magnetic field diagrams and to be made to realize that where the field is strong, the field lines will be close together and where the field is weak, the field lines will be further a. More practice is therefore required.

Question 5

For Parts (a) and (b) candidate were able to draw the truth table of the NAND gate and complete the table for the compound logic circuit.

In Part (c), the drawing of the SR NAND gate flip flop was poorly done. Some students had no idea what the flip flop was and as a result the drawings were completely wrong.

Part (d) which required candidates to draw the output of Q was very poorly done. It was obvious that many candidates had no exposure to this.

Recommendations

The flip flop is an area of the syllabus that teachers must pay more attention to, as too few students knew the diagram and those who knew it were not able to use the standard labelling convention for inputs and outputs.

Again teachers must pay very close attention to teaching the children to understand the and be able to draw activation table for a given flip-flop and

Question 6

Most candidates attempted all of the Parts of this question, with varying degrees of success.

For Part (a) candidates were aware of the experiment but many were unable to clearly state the conclusions drawn.

The graph in Part (b) (ii) was generally well known.

In Part (b) (iii), most candidates were able to calculate the mass defect in *amu*.

Most candidates were familiar with the concept of binding energy and mass defect in Part (b) (i) but some did not restrict the explanation to the nucleus but referred instead to the atom as a whole. There were also some who confused ionization energy with binding energy.

Most candidates were familiar with the mass-energy equation in Part (b) (iv), but most were unaware of the conversion process to kilograms.

Recommendations

Where possible, teachers should make use of multimedia. Videos of ionization radiation in a cloud chamber or the use of radioactive isotopes in medicine for diagnosis and treatment of cancer and other diseases etc. leave a longer lasting impression and cements understanding.

Some quick review of some CSEC® foundation work goes a long way in creating the correct frame of mind to focus on the topic at hand (work it into the set induction, maybe). Although syllabus completion imposes some time constraints, the basics (units, appropriate significant figures, graphing, to name a few) should not be neglected.

Paper 031 – School-Based Assessment (SBA)

General Comments

The quality of the experiments performed was, in general, of a satisfactory standard. The number of activities done was satisfactory, in most cases, and the range of topics covered was also good. It was pleasing to note that the standard of the mark schemes, as well as the marking, was acceptable and represented a slight improvement over the previous years. Although there was some improvement in the overall standard of the SBA process, there is still cause for concern as there are too many teachers who are not performing at a satisfactory level. The following comments provide feedback on specific areas of the SBA.

Mark Schemes and Marking

- Mismatched criteria – confusion between O/R/R and A/I skills.
- Criteria were too general - not specific to the activity.
- Too few criteria or too many marks per criterion – no breakdown of marks.
- Not enough feedback communicated to students recorded in the lab books.
- More care should be exercised by teachers when recording marks on EDPD forms 261 and 262.
- Not enough attention paid to the number of significant figures given in final answers.
- Not enough activities assessed and marked.

Standard and Presentation of Activities

- Too many standard textbook activities used to assess the Planning and Designing skill.
- Too few activities involving graph work and the use of advanced level equations were done.
- Too many basic Analysis and Interpretation activities were done.

Reminders and Recommendations

- Mark schemes should have criteria which are specific to the *activity* and the *skill* being assessed.
- A breakdown of the marks awarded for each skill should be clearly and appropriately recorded in each student's book.
- A greater amount of feedback should be given by the teacher to students in the form of detailed corrections and appropriate comments.
- A minimum of five activities should have graph work (including log graphs) and advanced level equations (including exponential equations) to assess the relevant skills.
- The line of best fit, the plotting of points, labelling axes and suitable scales should all be assessed under O/R/R and not A/I.
- The hypotenuse of the triangle used to calculate the gradient should be greater than one-half the length of the line drawn to represent the data.
- Axes should be labelled with quantity and unit and suitable scales should cause the graph to occupy more than one-half the graph paper along each axis.
- More attention should be paid to the accurate plotting of points and the readoff of values from the graph.

- Answers should be stated with units, where necessary, and an appropriate number of significant figures.

CARIBBEAN EXAMINATIONS COUNCIL

**REPORT ON CANDIDATES' WORK IN THE
CARIBBEAN ADVANCED PROFICIENCY EXAMINATION®**

MAY/JUNE 2018

PHYSICS

**Copyright© 2018 Caribbean Examinations Council
St Michael, Barbados
All rights reserved.**

GENERAL COMMENTS

CAPE Physics is a two-unit subject with each unit consisting of three modules.

Unit 1 has the following modules:

- Module 1 — Mechanics
- Module 2 — Oscillations and Waves
- Module 3 — Thermal and Mechanical Properties of Matter

Unit 2 has the following modules:

- Module 1 — Electricity and Magnetism
- Module 2 — AC Theory and Electronics
- Module 3 — Atomic and Nuclear Physics

Both units are examined by three papers. Papers 01 and 02 are external examinations, while Paper 031, the School-Based Assessment (SBA) is examined internally by teachers and moderated by CXC. Private candidates write Paper 032, which is an alternative to the SBA.

Paper 01 is a multiple-choice paper which comprises 45 compulsory multiple-choice items — 15 items per module. Paper 02 is a structured essay paper which comprises six compulsory questions, two questions per module.

Paper 031 is the School-Based Assessment component which comprises laboratory exercises and Paper 032 is a written paper which comprises three compulsory questions focusing on candidates' laboratory experiences.

In 2018, 2978 candidates wrote the Unit 1 examination while 2632 candidates wrote Unit 2. This represents a marked decrease (greater than 10 per cent) and increasing downward trend for Unit 1 when compared with the candidate entries for 2017 (Unit 1, 3067; Unit 2, 2170) and 2016 (Unit 1, 3366; Unit 2, 2571).

These numbers are worrisome when viewed against the background of an increasing need for STEM education and training in the world at large and particularly in the countries in our region. Physics is one of the major cornerstones of STEM and without a sufficient cadre of persons skilled in the application of the principles and ideas of this discipline to general life, it is unlikely that the development goals of the region can be realized. Further analysis needs to be done to determine whether this trend is also apparent at the CSEC level in Physics and other sciences. Principals and science teachers must try to take advantage of every opportunity to attract larger numbers of candidates to the sciences.

Overall, performance in the examination was good across both Unit 1 and Unit 2, with approximately 96 per cent and 98 per cent of candidates respectively, achieving acceptable grades, Grades I–V. These results show continued and consistent improvement over the last three years.

The recurring problems in both units, to which attention has been drawn over the last several years, was still very much alive in the 2018 scripts. These issues are mentioned repeatedly, and with emphasis, because they are such an important part of the toolbox which every physicist must carry and the skills developed in these areas are applicable to activities outside of physics itself. They include the following:

- *Unit conversion*: this occurs in every area of physics, even in the simplest of cases such as the measurement of length and distance where converting between different divisions of a metre — millimetre to metre, nanometres to micrometres to centimetres — defeats many candidates.
- *Manipulation of algebraic expressions*: especially where other operations such as square roots

are involved. For example, $\frac{c}{2\pi} = \sqrt{\frac{A}{LV}}$

These deficiencies can be eliminated by practice drills. Teachers should ensure that every student who studies CAPE Physics is competent in carrying out these operations.

DETAILED COMMENTS

UNIT 1

Paper 01 — Multiple Choice

Paper 01 consisted of 45 multiple-choice items. It was designed to provide adequate coverage of the content with items taken from sections of the three modules of the syllabus. The mean score was 63 out of 90 marks.

Paper 02 – Structured/Essay Questions

Question 1

This question tested candidate's knowledge of Newton's first law of motion and energy. It was well done. The mean score achieved was 9.7 out of 15 marks and the standard deviation was 3.1.

For Part (a), very few candidates were able to state Newton's first law of motion correct. While most candidates knew that an unbalanced or resultant external force was needed, many were

not able to state that this caused a body to remain in its state of rest or uniform velocity (uniform motion *in a straight line*). If they mentioned the two states, they left out *in a straight line* or *uniform*.

For Part (b) (i), most candidates demonstrated competence in the drawing of the graph. Many received total marks in this part of the question. A few candidates used bad scales or did not label their axes with both quantity and unit.

Many candidates knew that the maximum height was when the velocity was zero and hence read off the point where the graph cut the x-axis for Part (b) (ii). The problem was that many estimated the read off to the nearest line rather than reading off where the line actually passed.

While many candidates knew to use an equation of motion for Part (b) (iii), some did not substitute the acceleration due to gravity as a negative value and hence did not get the correct value for the maximum height. Some candidates successfully used other methods of finding the maximum height.

Some candidates were not able to recall any equation of motion to work out this part and a few had no idea what to do and left it out completely. Most candidates got Part (b) (iv) correct and successfully used the height to calculate the maximum potential energy.

Some candidates were able to say that the maximum potential energy would be less and to give a good reason to justify their response for Part (b) (v). Some knew it would be smaller but had no idea why. A few felt that the potential energy would increase and a small percentage left out this part completely.

Recommendations

Most candidates scored well on this question. However, a few candidates scored 15 marks, even though this concept is a CSEC one. Teachers should ensure that the candidates' CSEC knowledge is strong before building on this knowledge with CAPE concepts.

Teachers must also ensure that the direction analysis in the equations of motion are done thoroughly.

Question 2

This question tested candidates' knowledge about sound waves, their properties and cavity resonance. This question was done fairly well. The mean score achieved was 7.9 out of 15 marks and the standard deviation was 3.3.

For Part (a), the majority of candidates was able to relate loudness to amplitude/intensity and pitch to frequency/wavelength. However, very few were able to suggest a (correct) relationship for quality.

For Part (a) (i), the calculations done for $1/VV$ yielded answers with various numbers of significant figures, the most acceptable being three significant figures. For Part (a) (ii), many candidates lost their scale mark very easily as the numbers plotted would have used less than half of the page when the scale was started from zero. It was difficult for those candidates who used several significant figures in Part (b) to plot points to the same degree of accuracy. In some cases, even those who used three significant figures chose to plot points to two decimal places and lost marks for doing such.

Although candidates are by now familiar with the correct orientation for graphs, the labelling of axes is still posing a problem. In this case the unit for the x-axis, $m^{-3/2}$, was not straightforward and so many candidates left it out or wrote the wrong unit.

For Part (a) (iii), the use of large triangles to achieve better accuracy in the determination of the gradient of a line on a graph should be emphasized. This part of the question was fairly well done.

Candidates scored well on Part (b). The value obtained for the velocity depended on the gradient in Part (b) (iii). Rearrangement of the equation to make c the subject of the formula proved problematic for some candidates especially when dealing with the square root sign.

Question 3

This question tested candidates' knowledge about Young's modulus. It was not done well. The mean score achieved was 4.0 out of 15 marks and the standard deviation was 3.0.

Part (a) proved to be the easiest. Many candidates knew the experiment very well. Some candidates lost marks because they did not use a graphical method to determine Young's modulus. Teachers should point out the advantages of using graphs, wherever possible for determining physical quantities.

For Part (a) (i), many candidates could not draw a satisfactory line of best fit. It was apparent that not enough care was taken to balance the points when drawing the line. Determining the area under the graph proved challenging for many candidates and obtaining the full three marks was rare. Candidates challenges arose from not using a large enough area, the powers of 10 applied to each axis and the conversion required to express strain energy per unit volume in terms of $J\text{ mm}^{-3}$.

For Part (b) (i), many candidates did not even attempt to determine the ratio of the strain in the steel wire to the strain in the copper wire, as this required some algebraic manipulation. They just simply found the ratio of the two given quantities.

Part (b) (ii) was the most difficult for candidates. Many could not carry out the algebraic manipulation necessary to obtain the correct answer for the extension of the copper wire.

Comment

Examiners found that this question was particularly good at discriminating between strong physics candidates who understood concepts and those who merely memorized course material.

Question 4

This question tested candidates' knowledge about frictional forces. This question was not done well. The mean score achieved was 4.5 out of 15 marks and the standard deviation was 2.6.

Part (a) (i) was done fairly well but few candidates earned full marks. Marks were often lost due to a lack of attention to detail, (forgetting to mention that there are two types of friction); not reading the question carefully enough (forgetting to include types of friction such as drag and viscosity); and a lack of rigour in discussing even a well-known concept (not being careful to distinguish between the effect of static friction vs that of dynamic friction).

Part (b) (i) was also fairly well done. However, a large proportion of candidates presented diagrams that were incomplete in that at least one of the forces was left out or one of the distances was not labelled.

Most candidates who obtained full marks for Part (b) (i) were able to obtain the majority of the marks for Part (b) (ii). It was interesting to note that the majority of candidates preferred to use the elementary techniques of the principle of moments and Pythagoras's theorem rather than a more advanced approach of trigonometry and the resolution of forces.

Question 5

This question tested candidates' knowledge about simple harmonic motion (SHM). It was done fairly well. The mean score achieved was 6.0 out of 15 marks and the standard deviation was 3.9.

Part (a) required candidates to define the term 'simple harmonic motion' (SHM). The majority of candidates was knowledgeable of at least one of the two conditions necessary for an accurate definition of SHM. The most common being that *the acceleration of the object was directly proportional to its displacement from a fixed point*. The second condition when stated, was very often represented as *the acceleration was always directed in a direction opposite to the displacement* rather than the more common statement that *the acceleration was always directed towards the fixed point*. Too often, the reference to *the fixed point* was omitted. This is a reference that is essential to the conceptual understanding of SHM; failure to mention this therefore lead to candidates losing a mark.

Part (b) was the most well done part as the majority of candidates was able to accurately recall the required mathematical expression relating acceleration, a , to displacement, x , in simple harmonic motion.

Part (c) was also reasonably well done. The majority of candidates used the exchange in energy that took place during the oscillation of a simple pendulum as the example to describe the interchange of kinetic and potential energy in an oscillating system during SHM. Many candidates did not clearly state whether oscillation started at the amplitude or the equilibrium position, loosely referring to both as the 'rest position'. This sometimes led to them confusing the points in the oscillation where maximum KE and PE were achieved. In most cases, the fact that the total energy in the system remained constant was not stated.

In Part (d) (i), many candidates were unable to recall the equation to calculate the maximum speed of the particle, and failed to determine this speed by any other means. In Part (d) (ii), most candidates recognized that the maximum energy was attained by the particle when it was at its maximum speed. Some, however, did suggest that the maximum energy was the sum of its KE and PE, which, while not incorrect, obviously provided an erroneous result when the sum of the maximum KE and maximum PE was used.

A number of candidates interpreted that Part (e) asked for the horizontal circle described by the particle to be part of a conical pendulum. This assumption was incorrect. Many of those who obtained the correct solution lost a mark due to either the answer being quoted to the incorrect number of significant figures, or having incorrect or no units. The majority of the candidates who attempted Part (e) (ii) were successful; however, there were still a few who misquoted the equation for the period of a simple pendulum.

Recommendations

Teachers should insist that students pay attention to the importance of units, as they constitute a vital role in describing the physical quantity. Just as important is the understanding of the correct use of significant figures in determining the accuracy and relevance of the results derived from given data.

Question 6

This question tested candidates' knowledge about thermodynamics, kinetic theory and the gas laws. These topics are usually among the lowest performing questions both at the CSEC and CAPE levels. This question was a bit of an exception, as it ranked number 3 among the Unit 1 questions. The mean score achieved was 6.1 out of 15 marks and the standard deviation was 3.7.

Part (a) saw by far the best performance of all the parts in this question. Most candidates were familiar with the equation of state for an ideal gas and the correct answer was obtained by the correct substitution of the given variables into this equation. The candidates who were unable to gain the full three marks most often did not get more than one or two marks from the rest of the question.

Candidates were asked to provide qualitative explanations using the first law of thermodynamics and the kinetic theory of gases for Parts (a) (i) and (ii). As is very often the case, questions

requiring an explanation and the organization of ideas are not generally well done. Examiners, in an attempt to credit candidates for any evidence of knowledge were able to assign a few marks for most attempts at this question.

Parts (a), (d) and (e) required application of the first law of thermodynamics. Very few candidates were able to obtain full marks as there seemed to be confusion regarding the signs of the various quantities.

Paper 032 – Alternative to School-Based Assessment (SBA)

This paper was not well done. This was surprising because the experiments were basic experiments that can be found in any advanced level textbook.

Candidates need to ensure that they take the time to familiarize themselves with the experiments required in the syllabus.

Question 1

This question required candidates to perform an experiment to determine the focal length of a lens.

Most candidates seemed to be able to perform the experiment well as evidenced by their results. However, only some candidates were able to complete the table correctly.

The graphs for the most part were plotted well. However, only an extremely small number of candidates knew that the y-intercept represented the value $\frac{1}{f}$. Most of them went through the process of finding the gradient of the line.

It was clear that most candidates did not know the equation $\frac{1}{u} + \frac{1}{v} = \frac{1}{f}$ and hence had no idea how to manipulate the results from the experiment.

This is a basic experiment and should have been covered in the content of the module, and it is very surprising that it was not well known.

Question 2

In this question, candidates were required to complete the calculations for an experiment for which they were given results. Most candidates were able complete the table by inserting values for $\lg T$ and $\lg r$ and to plot the graph correctly.

Candidates were unable to use the log equation given and to determine that the y-intercept = $\frac{1}{2}$ lgk. As a result, the vast majority of them omitted the calculations completely or did them incorrectly.

Even the manipulation of the final equation to determine the mass of Jupiter seemed to be beyond the skill level of most candidates and quite a number of them did not even attempt it.

Question 3

This question required candidates to plan and design an experiment to determine the specific heat capacity of an unknown liquid. It was very poorly done.

Even though this question is a basic textbook experiment, a surprising number of candidates were unable to adequately describe the experiment.

Most candidates were unable to give a complete list of the apparatus required and those who did/could not describe the experiment and give a proper explanation of how the specific heat capacity of the liquid can be calculated from the experiment.

UNIT 2

Paper 01 — Multiple Choice

Paper 01 consisted of 45 multiple-choice items. It was designed to provide adequate coverage of the content with items taken from sections of the three modules of the syllabus. The mean score was 66 out of 90 marks.

Paper 02 – Structured/Essay Questions

Question 1

This question tested candidates' knowledge of resistivity and how resistance varies with temperature. The mean score achieved was 6.4 out of 15 marks and the standard deviation was 3.3.

Many candidates did not recognize that R was multiplied by $1000(10^3)$ for Part (a), and hence obtained wrong values for $\ln R$. In addition, there were inconsistencies with the number of significant figures and decimal places used for the values of $\ln R$.

Teachers need to emphasize to students the need to pay attention to the powers of 10 that variables are multiplied by especially when reading values off the scales on a graph.

For Part (b), few candidates obtained full marks, many obtained two to three marks. Candidates had challenges with the choice of scale and chose scales that were inappropriate, and hence the

graph occupied less than half the grid. Also, candidates had issues with the correct placement of axes and the units.

Teachers should emphasize to students the importance of choosing appropriate scales when plotting graphs, and this should be demonstrated during their lab work.

Candidates had problems manipulating the natural log equation for Part (c). Many did not state the units of β correctly. The majority showed that they knew how to calculate the gradient of a line, but some had problems with the read off.

Teachers should ensure that students practise questions where they have to manipulate exponential equations into a linear equation since not all students who study Physics also study Mathematics.

The majority of candidates was able to name the type of thermometric device used in the investigation for Part (d). However, providing a justification proved more challenging.

Part (e) was poorly done. Not many candidates were able to provide all three differences between the resistivity of the conductor and that of most metallic conductors.

Question 2

This question tested candidates' knowledge about light dependent resistors (LDRs). The mean score achieved was 7.4 out of 15 marks and the standard deviation was 3.1.

For Part (a), most candidates knew that LDR was an abbreviation for light dependent resistor and that it is a device whose resistance varies with the intensity of the light falling on it. However, some candidates could not explain why the resistance of the device varied with change in incident light intensity. They did not all infer any relationship between the photoelectric effect or the release of charge carriers and increased light intensity.

Candidates were able to find logarithms of values and plot the required graph from the given data in Part (b). Candidates did not maintain consistency in recording to a specific number of decimal places. Most candidates were able to draw a satisfactory line of best fit on the log-log graph in Part (c).

For Part (d), many candidates were unable to obtain a final result as they were not able to calculate the take-off voltage of a potential divider. Most candidates were able to calculate the value of R when the voltage dropped below 7.5 volts in Part (e).

Question 3

This question tested candidates' knowledge about radioactive decay. The mean score achieved was 8.1 out of 15 marks and the standard deviation was 4.0.

Approximately 50 per cent of candidates got Part (a) (i) correct. There were some who wrote other equations of radioactive decay, for example, $A = \lambda N$. For Part (a) (ii), a significant number of candidates were unable to identify that λ is the decay constant but the majority of those who did knew the unit and quoted it correctly.

For Part (b) (i), most candidates were competent in the plotting of the graph and were awarded full marks. A few candidates used bad scales or did not label their axes with both quantity and unit. A point to note though is that the curves were not smooth as many candidates had difficulty drawing a reasonable curve.

For Part (b) (ii), very few candidates were able to draw suitable tangents to a curve and obtain a reasonable read-off value. Quite a few drew a line from the (0, 0) point up to the graph.

Many candidates read off the point where the tangent cut the x-axis in Part (b) (iii). The majority of candidates were able to obtain full marks by accurately calculating the half-life in Part (c). For Part (d), although many candidates were able to calculate the half-life of the decay, some of them did not read off their graphs correctly. In addition, many were unable to give good reasons why there would be a discrepancy in the readings.

Some candidates used the equation in Part (e) to work out this part of the question and this involved calculating λ . While most did this calculation correctly, they were then unable to put it successfully into the equation, especially in converting the time to the correct unit.

Other candidates calculated the number of half-lives passed and used the brute force method of calculating the mass remaining. A few used $N = N_0/2^n$ and calculated the remaining mass. Many candidates did not gain marks in this part because they were unsure of how to find the mass remaining after four hours.

Recommendations

This question was reasonably well done. Equations and their symbols and units must be revised carefully so that symbols and units are not confused.

Also, to calculate the mass remaining could have been done on CSEC knowledge and a disappointing number of candidates were unable to do this very simple calculation. Teachers must ensure that students' CSEC knowledge is strong before attempting to introduce CAPE concepts.

Question 4

This question tested candidates' knowledge of lightning formation and electric charges. Candidates' knowledge of this topic was limited and there were quite a few instances where

candidates did not even attempt the question. The mean score achieved was 4.9 out of 15 marks and the standard deviation was 3.2.

For Part (a) (i), most candidates could not succinctly describe the conditions necessary for lightning formation and why it would be dangerous. The conditions given were convoluted and incoherent.

For Part (a) (ii), the vast majority of candidates did not know the term *breakdown* in terms of electric insulators/electric fields and so could not define it nor state conditions under which it would occur.

For Part (a) (iii), some candidates were able to describe the structure and function of the lightning rod but there were quite a few who were unable to do so. Given that this is a CSEC concept, it was rather disappointing to see the number of candidates who could not attempt this part of the question.

For Part (b), some candidates drew the forces due to the $6\ \mu\text{C}$ and the $18\ \mu\text{C}$ correctly. Quite a few of them placed their arrows in the wrong directions indicating that either they did not read the question carefully or they did not understand the question.

For Part (c), a few candidates were able to do the calculations of the forces correctly. Some did not find the distance between the $10\ \mu\text{C}$ and $18\ \mu\text{C}$ forces and so that calculation was not correct even if they had the correct equation. Many candidates did not know the correct equation for finding the force between two point charges and some did not know that $\mu\text{C} = 10^{-6}\ \text{C}$.

For Part (d), finding the resultant vertical force proved to be an insurmountable task for the majority of candidates, even those who had found the values of the forces correctly in the previous part of the question. Many did not realize that they were required to find the vertical component of the F_{18} force and add it to the F_6 force. As a result, the majority of candidates scored zero in this part.

Recommendations

Teachers must ensure that adequate practice is done with equations and the manipulation of equations. The drawing of forces on point charges due to other point charges must be done. All scientific terms must be used even in the explanation of concepts so that terms are not strange to students and so that they are able to use and explain them.

Vector components, though covered in Unit 1, should also be reinforced in Unit 2 and students given the opportunity to apply their knowledge of the topic. Teachers should ensure that students have adequate practice in this area.

Unit prefixes, a very important topic in Unit 1, is also applicable in Unit 2. Consistent practice in these topics will ensure that students do not forget simple concepts.

Question 5

This question tested candidates' knowledge of operational amplifiers. It was not as well done as was expected and a relatively large number of candidates scored zero (0).

For Part (a), the majority of candidates knew the properties of an *ideal* operational amplifier, mainly because the terms *infinite* or *zero* were used to describe the properties of an ideal op. amp.

However, a relatively small number of candidates could state typical values for the *real* operational amplifier. Many of them either gave a range of values or a qualitative description, which was usually the opposite of the description used for the ideal op. amp.

Part (b) was generally poorly done. The majority of candidates did not seem to know what was expected.

The main errors made by candidates in Part (b) (i) included the following

- Not recognizing that the gain was to be calculated (or how to calculate it)
- Not recognizing that the gain was negative
- Failing to recognize that the V–t graph of the output was inverted
- Failing to recognize that the shape of the graph was triangular/a saw tooth. Most of them gave a sinusoidal trace.

The main errors made by the candidates in Part (b) (ii) included the following

- Not recognizing that saturation occurred at 10 V
- Not showing the times at the beginning and the end of the saturation period
- Carrying forward errors from Part (b) (i)

For Part (c), the majority of the candidates stated that $V = 0$ V, but many of them could not give the reason. Most of those who earned the marks for this section mentioned *virtual earth* in their explanation.

Question 6

This question tested candidates' knowledge of the photoelectric effect. The mean score achieved was 5.8 out of 15 marks and the standard deviation was 4.3.

For Part (a), candidates did not realize that there was a specific cut-off frequency for any metal involved in the photoelectric effect, although they knew that the photoelectric effect resulted in

the liberation of electrons from a metal surface. Most candidates knew the units for cut-off wavelength and work function.

Most of the definitions given were only partially correct for Part (b). In many cases being somewhat loose and omitting at least one of the main elements of the definition.

Candidates had great difficulty in obtaining a correct expression for the maximum speed of the emitted photoelectrons for Part (c) (i). The weaknesses in manipulation of algebraic expressions to obtain a given format was very evident in this part of the question.

As a result of the challenges seen in Part (c) (i), for Part (c) (ii), candidates did not attempt to calculate the required speed in this part nor did they convert the work function to Joules. Incomplete substitutions were made that yielded incorrect answers.

Paper 032 – Alternative to School-Based Assessment (SBA)

Performance on this paper was quite poor. The majority of candidates appeared to be unfamiliar with lab equipment and seemed to experience difficulty in carrying out and interpreting measurements. Every effort needs to be made to expose private candidates to lab procedures and practices as a natural part of their Physics education.

Candidates and their tutors should try to ensure that they perform at least two experiments in each of the modules of the syllabus before sitting the Alternative to School-Based Assessment examination.

Question 1

This question required candidates to perform an experiment to determine the resistivity of a salt solution. The experiment employed a brine cell which when placed in an electric circuit was nothing more than a different form of resistor. What was required of candidates was the recording of voltages and currents in the circuit while adjusting a variable resistor.

Most candidates seemed unfamiliar with the layout of a DC series circuit as evidenced by their results showing that they took measurements at the wrong points in the circuit. However, the few candidates who were able to obtain reasonable results were able to plot the graph fairly well and some of them were able to read off correctly and obtain a satisfactory value for the gradient. Very few were able calculate the slope for the resistivity of the brine solution.

Question 2

In this question candidates were required to perform calculations based on a given set of experimental results.

The majority of candidates was able to find the reciprocals of the given current values although several failed to incorporate the required unit conversion from mA to A⁻¹. Candidates were able to plot satisfactory graphs using their calculated results. The question also required candidates to manipulate a given equation so that the relationship between the slope and intercept of their graph and the device characteristics would be apparent. The required algebraic manipulation proved difficult for the majority of candidates and they were unable to carry the question to completion.

Candidates and their tutors are again reminded of the need for basic proficiency in algebra in order to study CAPE Physics successfully.

Question 3

This question required candidates to design an experiment to test the validity of a candidate's hypothesis that the fall of the liquid level in an open burette obeys an exponential law.

Candidates were unable to give a complete list of the apparatus required and even those who did could not describe the experiment and give a proper explanation of how to validate an exponential law.

Although similar experiments can be found in a variety of textbooks, the majority of candidates seemed not to know how to approach the question.